

A. 主体関係 / Machine body / Maschinengehäuse / Corps de la machine / Cuerpo de la máquina

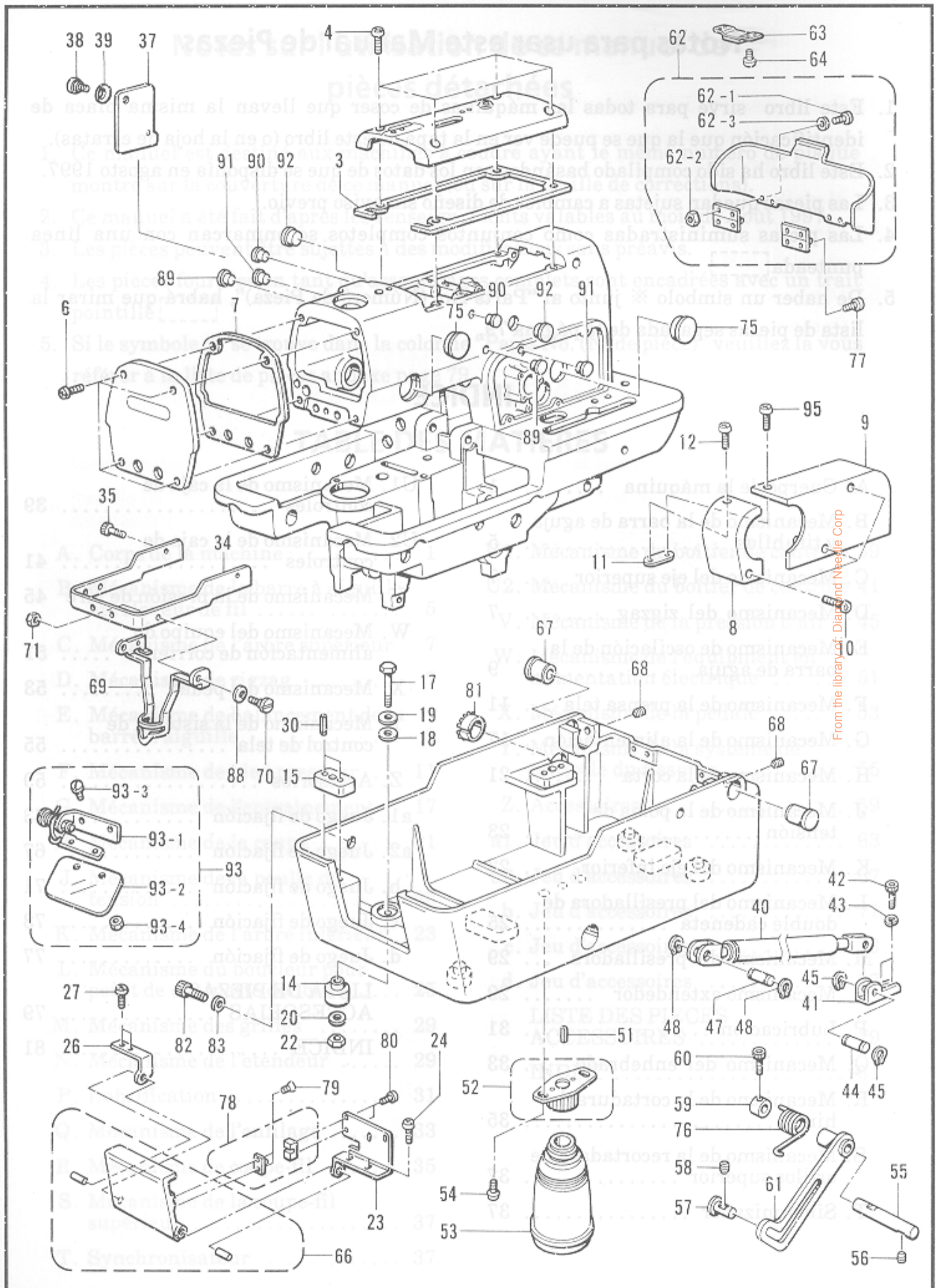

From the library of: Diamond Needle Corp

A. 主体関係 / Machine body / Maschinengehäuse / Corps de la machine / Cuerpo de la máquina

REF.NO.	CODE	Q'TY	ヒンメイ	NAME OF PARTS	RM
3	S35231000	1	ウワフタパツキン	TOP COVER PACKING	
4	062501202	4	ナベコM5X12	SCREW, PAN M5X12	
6	062500804	2	ナベコ5X8	SCREW, PAN M5X8	
7	S35229000	1	メンイタパツキン	FACE PLATE PACKING	
8	S35227009	1	ベルトカバーF	BELT COVER (F)	
9	S35228009	1	ベルトカバーR	BELT COVER (R)	
10	062501202	3	ナベコM5X12	SCREW, PAN M5X12	
11	S35226001	1	ベルトカバーササエ	BELT COVER SUPPORT	
12	062400812	1	ナベコ4X8	SCREW, PAN M4X8	
14	158827009	4	ベッドダイクツシヨンA	BED BASE CUSHION (A)	
15	S35225000	4	ベッドダイクツシヨン	BED BASE CUSHION	
17	S21728001	4	ボルト6X80	BOLT, M6X80	
18	159458009	4	ゴムシート	RUBBER SHEET	
19	115947001	4	ザガネ	WASHER, PLAIN 6.35	
20	025060332	4	ヒラザガネダイ6	WASHER, PLAIN L 6	
22	021060102	4	ナツト1シユ6	NUT, 1 M6	
23	S35203001	1	カバーササエイタR	COVER SUPPORT PLATE (R)	
24	062400812	2	ナベコ4X8	SCREW, PAN M4X8	
26	S35224001	1	カバーササエイタL	COVER SUPPORT PLATE (L)	
27	062400812	2	ナベコ4X8	SCREW, PAN M4X8	
30	047502242	8	スプリングピンAW5	PIN, SPRING ROLL AW5	
34	S35223101	1	ハリカイドウカバー	NEEDLE ROTATION COVER	
35	018400832	4	アナボルト4X8	BOLT, SOCKET M4X8	
37	S35222001	1	ハリフリマドフタ	ZIGZAG WINDOW COVER	
38	S35221001	1	ダンネジM4	SHOULDER SCREW, M4	
39	107017002	1	ナミバネザガネ	WASHER, WAVE SPRING 6.45	
40	S35201000	1	ガススプリング	GS SPRING	
41	S35220101	1	GSササエイタ	GS SUPPORT PLATE	
42	018501222	2	アナボルト5X12	BOLT, SOCKET M5X12	
43	028050242	2	バネザガネ2-5	WASHER, SPRING 2-5	
44	S35219001	1	GSササエピンR	GS SUPPORT PIN (R)	
45	048080142	2	トメワジクヨウC8	RETAINING RING, C8	
47	S35218001	1	GSササエピンF	GS SUPPORT PIN (F)	
48	048080142	2	トメワジクヨウC8	RETAINING RING, C8	
51	047502242	1	スプリングピンAW5	PIN, SPRING ROLL AW5	
52	154465001	1	ハイユキヤツブササエクミ	DUST OILER SUPPORT ASSY	
53	114486002	1	ポリオイラータイ	OILER	
54	062500812	2	ナベコ5X8	SCREW, PAN M5X8	
55	S35217001	1	ヒンジレバーササエジク	HINGE LEVER SUPPORT SHAFT	
56	014060632	1	アナトメ6X6クボミ	SET SCREW, SOCKET (CP) M6X6	
57	S35216001	1	ヒンジレバーシテンジク	HINGE LEVER SHAFT	
58	014060632	1	アナトメ6X6クボミ	SET SCREW, SOCKET (CP) M6X6	
59	S35215001	1	セツトカラー	SET SCREW COLLAR	
60	018061236	1	アナボルト6X12	BOLT, SOCKET M6X12	
61	S17965001	1	トウブササエレバー	HEAD SUPPORT LEVER	
62	S35214009	1	ベッドダイカバークミ	BED BASE COVER ASSY	
62-1	008300604	4	+トラスコ3X6	SCREW, TRUSS M3X6	
62-2	021300206	4	2シユナツト3	NUT, 2 M3	
62-3	025030232	4	ヒラザガネチユウ3	WASHER, PLAIN M 3	
63	S35212000	1	マグネットキヤツチ	MAGNET CATCH	
64	062300512	2	ナベコ3X5	SCREW, PAN M3X5	
66	S35211009	1	マエカバークミ	FRONT COVER ASSY	
67	S35207001	2	ヒンジB	HINGE (B)	
68	014060632	2	アナトメ6X6クボミ	SET SCREW, SOCKET (CP) M6X6	
69	S35206201	1	フィンガーガード	FINGER GUARD	
70	S35221001	2	ダンネジM4	SHOULDER SCREW, M4	
71	021400202	2	2シユナツト4	NUT, 2 M4	
75	150607009	2	ゴムセン32.8	RUBBER CAP, 32.8	

From the library of: Diamond Needle Corp

A. 主体関係 / Machine body / Maschinengehäuse / Corps de la machine / Cuerpo de la máquina

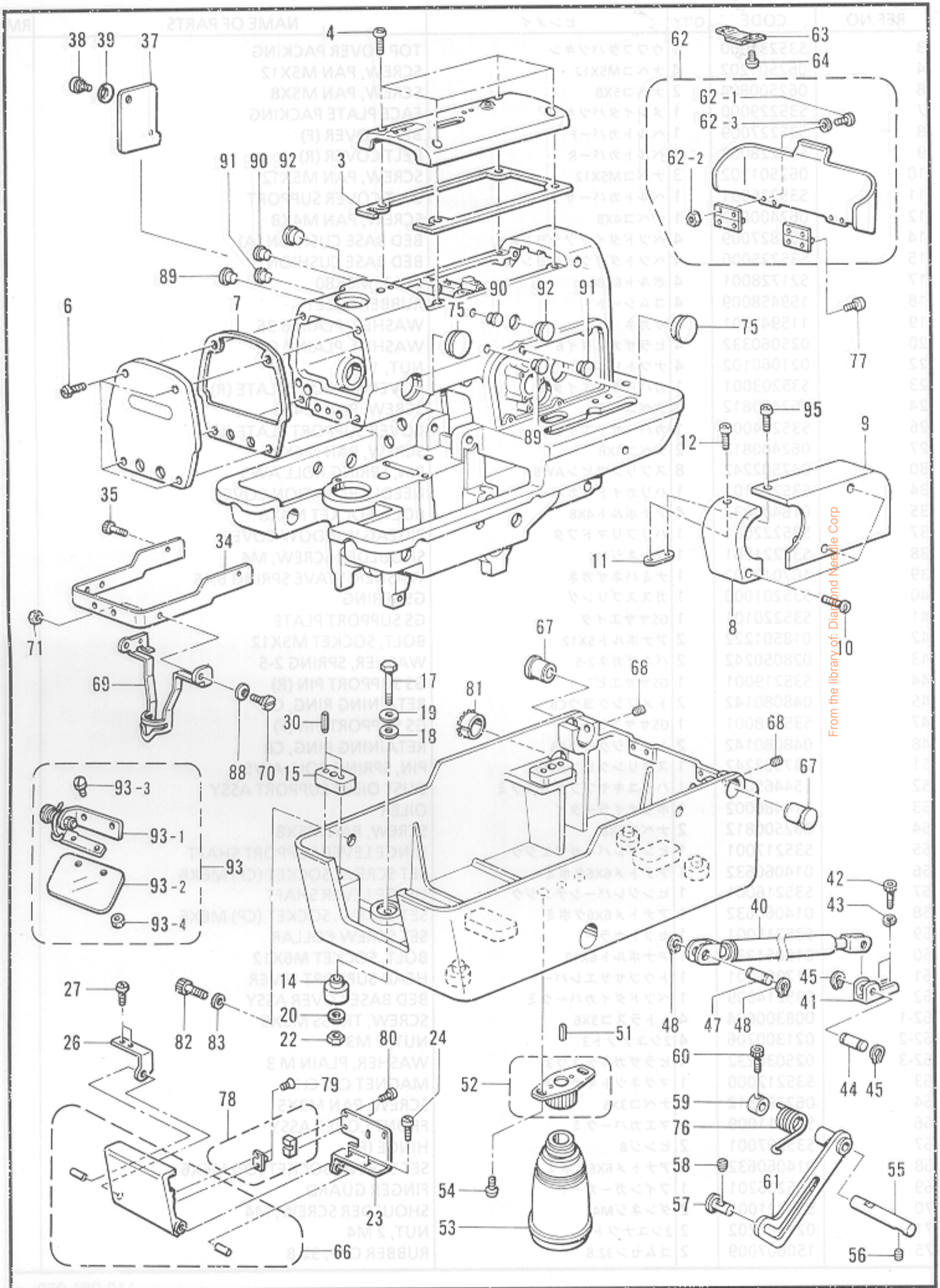

A. 主体関係 / Machine body / Maschinengehäuse / Corps de la machine / Cuerpo de la máquina

REF.NO.	CODE	Q'TY	ヒンメイ	NAME OF PARTS	RM
76	S35204001	1	ベッドヒンジバネ	BED HINGE SPRING	
77	062300512	4	ナベコ3X5	SCREW, PAN M3X5	
78	S33899000	1	ボールキヤツチクミ	BALL CATCH ASSY	
79	004300513	2	+サラコ3X5	SCREW, FLAT M3X5	
80	062300616	2	ナベコM3X6	SCREW, PAN M3X6	
81	S35202000	1	ジザイブツシユ	FREE BUSH	
82	018082036	1	アナボルト8X20	BOLT, SOCKET M8X20	
83	025080132	1	ヒラザガネシヨウ8	WASHER, PLAIN S 8	
88	107017002	2	ナミバネザガネ	WASHER, WAVE SPRING 6.45	
89	117936009	1	ゴムセン9.4	RUBBER CAP, 9.4	
90	158437009	2	ゴムセン10	RUBBER CAP, 10	
91	S32264009	2	ゴムセン11.5	RUBBER CAP, 11.5	
92	150756009	2	ゴムセン18.5	RUBBER CAP, 18.5	
93	S37084001	1	アイガードクミ	EYE GUARD ASSY	
93-1	S37085001	1	アイガードトリツケイタクミ	EYE GUARD SET PLATE ASSY	
93-2	153098000	1	アイガード	EYE GUARD	
93-3	100257010	2	シメネジ3.57	SCREW, SM3.57	
93-4	106129002	2	ナツト3.57	NUT, SM3.57	
95	062400812	1	ナベコ4X8	SCREW, PAN M4X8	
96	062500804	2	ナベコ5X8	SCREW, PAN M5X8	
25	S35132001	1	ハリボウブロッククミ	NEEDLE BAR BLOCK ASSY	
26	S35138001	2	ハリボウガイドカラー	NEEDLE BAR GUIDE COLLAR	
27	153675001	2	ナットネジ4.37	SET SCREW, SOCKET SM4.37	
28	S35137001	2	ハリボウガイド	NEEDLE BAR GUIDE	
29	S35136001	2	ハリボウガイドバネ	NEEDLE BAR GUIDE SPRING	
30	S35135001	1	ハリボウアンナイ	NEEDLE BAR GUIDE SUPPORT PLATE	
31	062300616	2	ナベコM3X6	SCREW, PAN M3X6	
32	S35134001	1	ハリボウギヤササエ	NEEDLE BAR GEAR SUPPORT (A)	
33	018080136	2	アナボルト5X10	BOLT, SOCKET M5X10	
35	S35132101	1	スレッド	THREAD TAKE-UP ASSY	
35-1	S35129001	1	スレッドカムコロシヤ	THREAD TAKE-UP CAM ROCKER SHAFT	
35-2	021800303	1	ナツトネジ5	SET SCREW, SOCKET SM5	
35-3	S35131001	1	スレッドカムコロ	THREAD TAKE-UP SPRING GUARD	
36	S35128001	1	スレッドカムコロ	THREAD TAKE-UP SUPPORT SHAFT	
37	014060622	2	ナットネジ6.37	SET SCREW, SOCKET (CP) M6.37	
38	S23613001	1	カラー	SET SCREW COLLAR ASSY	
39	S35127001	1	スレッドカムコロ	THREAD TAKE-UP CAM ROCKER	
40	S35125001	1	スレッドカムコロ	THREAD TAKE-UP SPRING	
41	S35078001	1	スプリングフック	SPRING HOOK	
42	S35125000	1	ベアリング25/20	BEARING 25/20	
43	S35124000	1	スラストベアリング	THRUST BEARING	
44	S35123000	1	スラストワッシャー	THRUST WASHER	
45	S35122000	1	ハリボウブロックフェルト	NEEDLE BAR BLOCK FELT	
46	S35121000	1	ハリボウフェルト	NEEDLE BAR FELT	
47	100257010	1	シメネジ3.57	SET SCREW, SOCKET (CP) SM3.57	
48	S35120001	1	ハリボウアンナイ	THREAD GUIDE (A)	
49	T4T5T4002	1	ハリボウアンナイ	SHOULDER SCREW	
50	S35118001	1	ハリボウアンナイ	TENSION SPRING	
51	S35117001	1	ハリボウメタルナツ	NUT, NEEDLE BAR BUSH (U)	
52	S35116001	1	ハリボウメタルナツ	SPRING, NEEDLE BAR BUSH (U)	
53	S35115001	2	ハリボウメタルナツ	RING, NEEDLE BAR BUSH (U)	
54	S35114001	1	ハリボウギヤササエ	NEEDLE BAR GEAR SUPPORT (B)	
55-1	018400830	2	ナットネジ4.37	BOLT, SOCKET M4X8	
55-2	S17608009	1	ナットネジ4.37	SET SCREW COLLAR	
56	014060622	2	ナットネジ6.37	SET SCREW, SOCKET (CP) M6.37	
57	S35113001	1	ハリボウブロックカラー	NEEDLE BAR BLOCK COLLAR	
58	S37088001	1	ハリボウガード	NEEDLE BAR GUARD	
59	062300512	3	ナベコ3X5	SCREW, PAN M3X5	

From the library of: Diamond Needle Corp



B. 針棒・天秤関係 / Needle bar and thread take-up mechanism / Nadelstange und Fadenabnahmevorrichtung / Mécanisme de la barre à aiguille et releveur de fil / Mecanismo de la barra de aguja y tirahilos

REF.NO.	CODE	Q'TY	ヒンメイ	NAME OF PARTS	RM
1	S35346001	1	クドウロツドクミ	RIVING ROD ASSY	
2	S35339001	1	ハリクドウギヤジク	DRIVING GEAR SHAFT	
3	014060632	2	アナトメ6X6クボミ	SET SCREW, SOCKET (CP) M6X6	
7	S35340001	1	クドウロツドピン	DRIVING ROD PIN	
8	S35337001	1	ハリボウクドウレバー	NEEDLE BAR DRIVING LEVER	
9	014060632	1	アナトメ6X6クボミ	SET SCREW, SOCKET (CP) M6X6	
10	S35338001	1	ハリクドウレバージク	DRIVING LEVER SHAFT	
11	014060632	2	アナトメ6X6クボミ	SET SCREW, SOCKET (CP) M6X6	
12	S35335001	1	セツトカラーウミ	SET SCREW COLLAR ASSY	
13	S35334001	1	ハリボウヨーク	NEEDLE BAR YORK	
14	S35333001	1	ハリボウスイハイリンク	NEEDLE BAR LEVEL FEED LINK	
15	S35332001	2	ハリボウダキ	NEEDLE BAR CLAMP	
16	018301236	2	アナボルト3X12	BOLT, SOCKET M3X12	
17	S35331101	1	ハリボウクミ	NEEDLE BAR ASSY	
18	140553102	1	アタマツキトメネジ3.18	SET SCREW, SM3.18	
19	S35148001	1	ハリボウメタルU	NEEDLE BAR BUSH (U)	
20	S37087001	1	ハリボウメタルオサエダイB	NEEDLE BAR BUSH PRESSER (B)	
21	018402032	3	アナボルト4X20	BOLT, SOCKET M4X20	
22	S35144001	1	ハリボウスイハイリンク	NEEDLE BAR LEVEL FEED LINK	
23	S37432001	1	ハリボウブロックダキクミ	NEEDLE BAR BLOCK CLAMP ASSY	
23-1	018301632	1	アナボルト3X16	BOLT, SOCKET M3X16	
25	S35142001	1	ハリボウブロッククミ	NEEDLE BAR BLOCK ASSY	
26	S35138001	2	ハリボウガイドカラー	NEEDLE BAR GUIDE COLLAR	
27	153675001	2	アナトメネジ4.37	SET SCREW, SOCKET SM4.37	
28	S35137001	2	ハリボウガイド	NEEDLE BAR GUIDE	
29	S35136001	2	ハリボウガイドバネ	NEEDLE BAR GUIDE SPRING	
30	S35135001	1	ハリボウアンナイササエイタ	NEEDLE BAR GUIDE SUPPORT PLATE	
31	062300616	2	ナベコM3X6	SCREW, PAN M3X6	
32	S35134001	1	ハリボウギヤササエA	NEEDLE BAR GEAR SUPPORT (A)	
33	018501036	2	アナボルト5X10	BOLT, SOCKET M5X10	
35	S35132101	1	テンピンクミ	THREAD TAKE-UP ASSY	
35-1	S35129001	1	テンピンカムコロジク	THREAD TAKE-UP CAM ROLLER SHAFT	
35-2	021500303	1	ナツト3シユ5	NUT, 3 M5	
35-3	S35911101	1	テンピンバネウケ	THREAD TAKE-UP SPRING GUARD	
36	S35128001	1	テンピンササエジク	THREAD TAKE-UP SUPPORT SHAFT	
37	014060632	2	アナトメ6X6クボミ	SET SCREW, SOCKET (CP) M6X6	
38	S23612001	1	セツトカラーウミ	SET SCREW COLLAR ASSY	
39	S35127001	1	テンピンカムコロ	THREAD TAKE-UP CAM ROLLER	
40	S35126001	1	テンピンバネ	THREAD TAKE-UP SPRING	
41	S35078001	1	バネカケ	SPRING HOOK	
42	S35125000	1	ジクウケ25/20	BEARING 25/20	
43	S35124000	1	スラストベアリング	THRUST BEARING	
44	S35123000	1	スラストワツシヤ	THRUST WASHER	
45	S35122000	1	ハリボウブロックフェルト	NEEDLE BAR BLOCK FELT	
46	S35121000	1	ハリボウフェルト	NEEDLE BAR FELT	
47	148294001	1	アナトメネジ3.57クボミ	SET SCREW, SOCKET (CP) SM3.57	
52	S41310001	1	ハライトアンナイA	THREAD GUIDE (A)	
53	141514002	1	ハサミダンネジ	SHOULDER SCREW	
54	S35118001	1	ハライトチヨウシバネ	TENSION SPRING	
59	S35117001	1	ハリボウメタルUナツト	NUT, NEEDLE BAR BUSH (U)	
60	S35116001	1	ハリボウメタルUイタバネ	SPRING, NEEDLE BAR BUSH (U)	
62	S35115001	2	ハリボウメタルUリング	RING, NEEDLE BAR BUSH (U)	
63	S35114001	1	ハリボウギヤササエB	NEEDLE BAR GEAR SUPPORT (B)	
64	018400832	2	アナボルト4X8	BOLT, SOCKET M4X8	
65-1	S17608009	1	セツトカラー	SET SCREW COLLAR	
65-2	014060622	2	アナトメネジ6X6クボミ	SET SCREW, SOCKET (CP) M6X6	
66	S35113001	1	ハリボウブロックカラー	NEEDLE BAR BLOCK COLLAR	
67	S37088001	1	ハリボウガード	NEEDLE BAR GUARD	
68	062300512	3	ナベコ3X5	SCREW, PAN M3X5	
69	S41251001	1	ハライトオサエイタA	NEEDLE THREAD PRESSER PLATE (A)	

From the library of: Diamond Needle Corp

C. 上軸関係 / Upper shaft mechanism / Obere Welle / Mécanisme de l'arbre supérieur / Mecanismo del eje superior

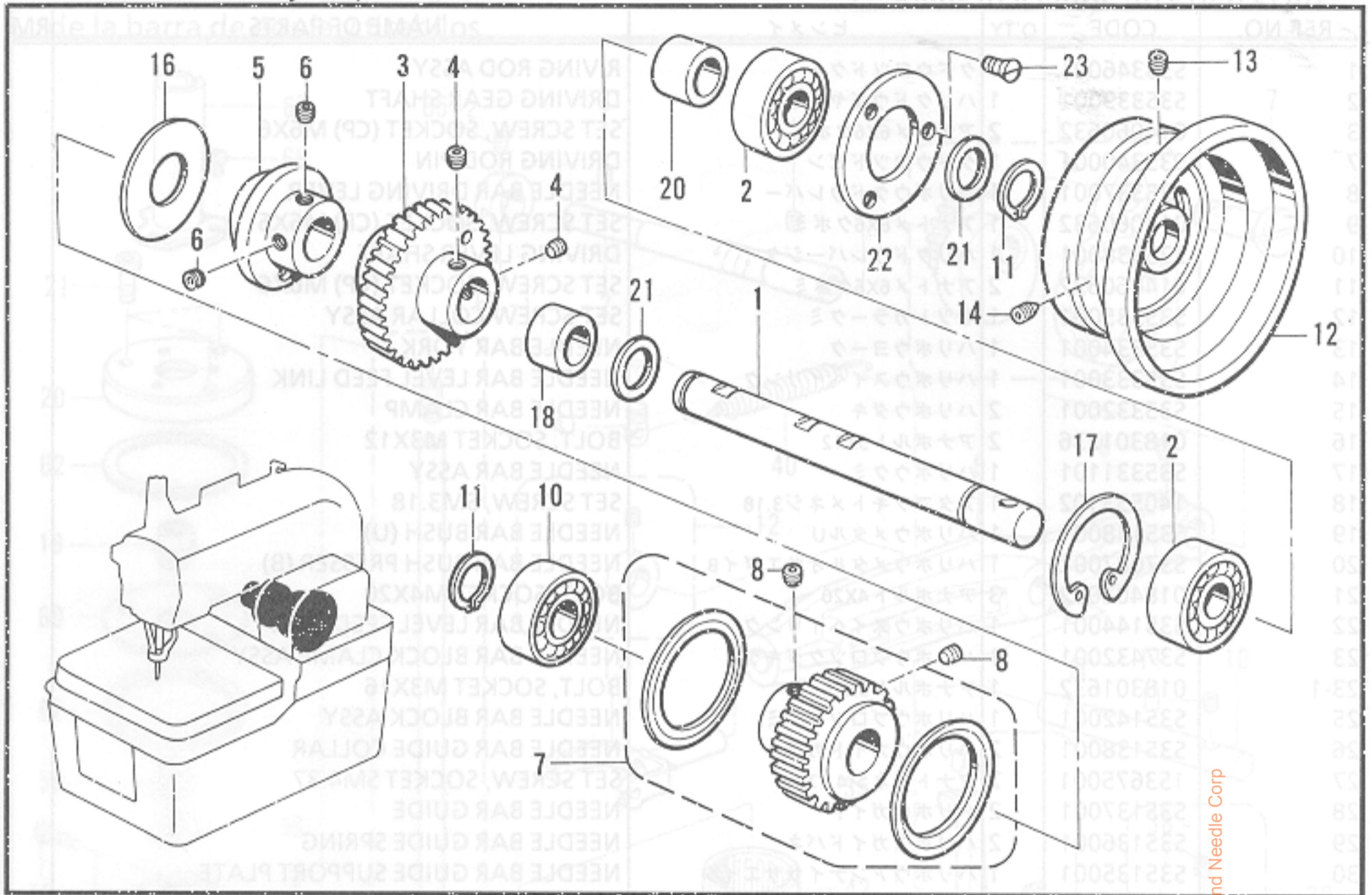

118-981-109

D. 針振関係 / Zigzag mechanism / Zickzackvorrichtung / Mécanisme de zigzag / Mecanismo del zigzag

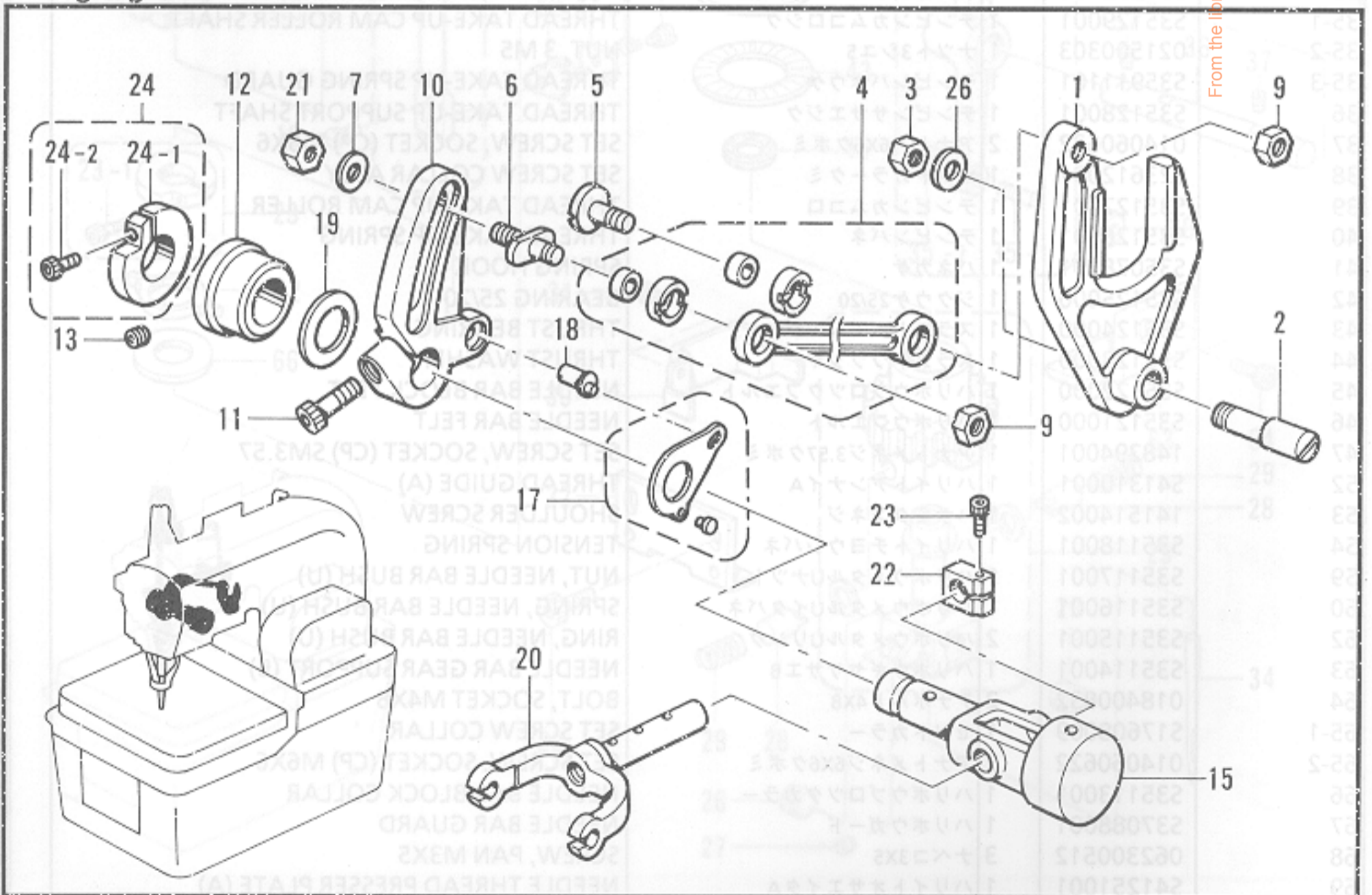

118-981-110

C. 上軸関係 / Upper shaft mechanism / Obere Welle / Mécanisme de l'arbre supérieur /  
Mecanismo del eje superior

REF.NO.	CODE	Q'TY	ヒンメイ	NAME OF PARTS	RM
1	S43710001	1	ウワジク	UPPER SHAFT	
2	072620260	2	タマジクウケ6202VVC2	BALL BEARING, 6202VVC2	
3	S35247001	1	ハリボウギヤ	NEEDLE BAR GEAR	
4	S23651001	2	アナヒラ6X6ホソメ	SET SCREW, SOCKET (FT) M6X6	
5	S35246001	1	ハリフリカム	ZIGZAG CAM	
6	S23651001	2	アナヒラ6X6ホソメ	SET SCREW, SOCKET (FT) M6X6	
7	S35245001	1	ウワジクTプーリクミ	UPPER SHAFT TENSION PULLEY ASSY	
8	S23651001	2	アナヒラ6X6ホソメ	SET SCREW, SOCKET (FT) M6X6	
10	076002450	1	タマジクウケ6002DD	BALL BEARING, 6002DD	
11	048150142	2	トメワジクヨウC15	RETAINING RING, C15	
12	S43708009	1	プーリクミ	PULLEY ASSY	
13	014060632	1	アナトメ6X6クボミ	SET SCREW, SOCKET (CP) M6X6	
14	016061031	1	アナトガリ 6X10	SET SCREW, SOCKET (CN) M6X10	
16	S35249001	1	スラストザガネ	THRUST WASHER	
17	048350242	1	トメワアナヨウC35	RETAINING RING, C35	
18	S43711000	1	ウワジクカラー	UPPER SHAFT COLLAR	
20	151998000	1	ベアリングカンザ	BEARING COLLAR	
21	116920001	1	オクリジクスラストリング	THRUST RING	
22	141276001	1	タマジクウケフタS	BALL BEARING CAP (S)	
23	102843004	3	サラネジ3.57	SCREW, FLAT SM3.57	

118-981-109

D. 針振関係 / Zigzag mechanism / Zickzackvorrichtung / Mécanisme de zigzag / Mecanismo del zigzag

REF.NO.	CODE	Q'TY	ヒンメイ	NAME OF PARTS	RM
1	S35264001	1	ハリフリフタマタ	ZIGZAG FORK	
2	S35263101	1	ハリフリフタマタササエピン	ZIGZAG FORK SUPPORT PIN	
3	021080306	1	ナット3シユ8	NUT, 3 M8	
4	S35262001	1	ハリフリレンカンクミ	ZIGZAG CONNECTING ROD ASSY	
5	S35260001	1	ダンネジM6	SHOULDER SCREW, M6	
6	S35259001	1	ハリフリクランクダンネジ	STUD SCREW, ZIGZAG CRANK	
7	155559001	1	ヒラザガネ	WASHER, PLAIN	
9	021060102	2	ナット1シユ6	NUT, 1 M6	
10	S35258001	1	ハリフリクランク	ZIGZAG CRANK	
11	018062022	1	アナボルト6X20	BOLT, SOCKET M6X20	
12	S35257000	1	クランクジクメタル	CRANK SHAFT BUSH	
13	014060632	1	アナトメ6X6クボミ	SET SCREW, SOCKET (CP) M6X6	
15	S35256001	1	ハリフリヨウドウジク	ZIGZAG ROCK SHAFT	
17	S35255001	1	ハリイチチヨウセツイタクミ	NEEDLE POSITION CONTROL PLATE ASSY	
18	S35252001	1	ハリフリヘンシンピン	ZIGZAG ECCENTRIC PIN	
19	148727001	1	スペーサー0.6	SPACER, 0.6	
20	S35250001	1	ハリフリウデ	ZIGZAG LEVER	
21	S35251001	1	ナット6	NUT, M6	
22	S35332001	1	ハリボウダキ	NEEDLE BAR CLAMP	
23	018301236	1	アナボルト3X12	BOLT, SOCKET M3X12	
24	S37432001	1	ハリボウブロックダキクミ	NEEDLE BAR BLOCK CLAMP ASSY	
24-1	S35143001	1	ハリボウブロックダキ	NEEDLE BAR BLOCK CLAMP	
24-2	018301632	1	アナボルト3X16	BOLT, SOCKET M3X16	
26	153596001	1	ザガネ	WASHER	

118-981-110



E. 針棒搖動關係 / Needle bar rocking mechanism / Nadelstangenbetätigung / Mécanisme de balancement de la barre à aiguille / Mecanismo de oscilación de la barra de aguja

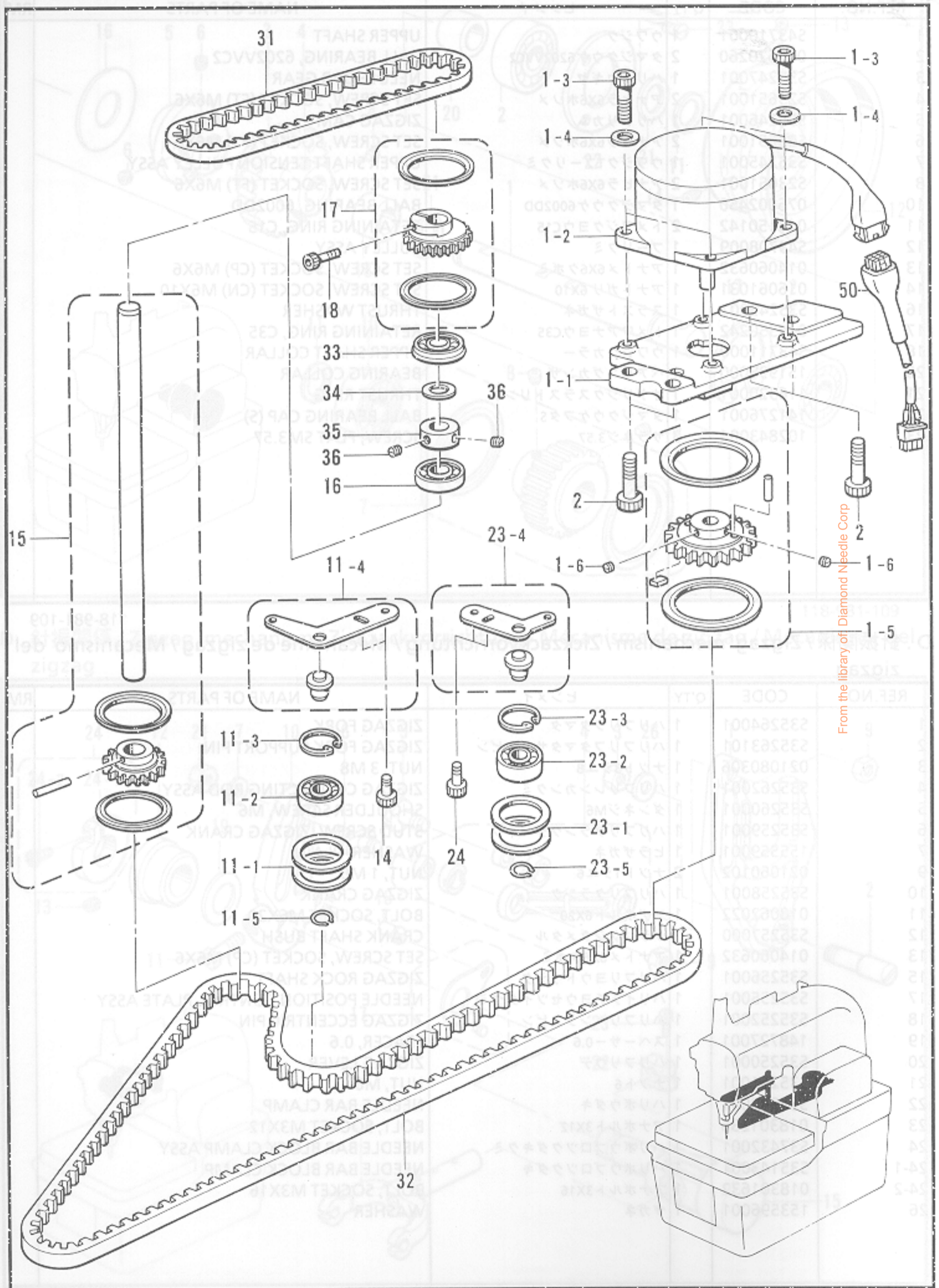

From the library of Diamond Needle Corp

E. 針棒揺動関係 / Needle bar rocking mechanism / Nadelstangenbetätigung / Mécanisme de balancement de la barre à aiguille / Mecanismo de oscilación de la barra de aguja

REF.NO.	CODE	Q'TY	ヒンメイ	NAME OF PARTS	RM
1-1	S35276001	1	モータベース	MOTOR BASE	
1-2	S43285000	1	パルスモータRクミ	PULSE MOTOR (R) ASSY	
1-3	018501422	4	アナボルト5X14	BOLT, SOCKET M5X14	
1-4	025050232	4	ヒラザガネチユウ5	WASHER, PLAIN M 5	
1-5	S35283001	1	ハリカイドウブーリクミ	NEEDLE ROTATION PULLEY ASSY	
1-6	014060632	2	アナトメ6X6クボミ	SET SCREW, SOCKET (CP) M6X6	
2	018061622	4	アナボルト6X16	BOLT, SOCKET M6X16	
11	S35291001	1	テンションブーリDクミ	TENSION PULLEY (D) ASSY	
11-1	S35284001	1	テンションブーリ	TENSION PULLEY	
11-2	076000800	1	タマジクウケ6000ZZ	BALL BEARING, 6000ZZ	
11-3	048260242	2	トメワアナヨウC26	RETAINING RING, C26	
11-4	S35290001	1	テンションブーリウデDクミ	TENSION PULLEY ARM (D) ASSY	
11-5	048100142	1	トメワジクヨウC10	RETAINING RING, C10	
14	018400832	2	アナボルト4X8	BOLT, SOCKET M4X8	
15	S35296001	1	レースカイドウジククミ	DRIVING LOOPER SHAFT ASSY	
16	072620180	1	タマジクウケ6201ZZ	BALL BEARING, 6201ZZ	
17	S35297000	1	タデジクTブーリUクミ	VERTICAL SHAFT (T) PULLEY (U) ASSY	
18	018401636	1	アナボルト4X16	BOLT, SOCKET M4X16	
23	S35288001	1	テンションブーリUクミ	TENSION PULLEY (U) ASSY	
23-1	S35284001	1	テンションブーリ	TENSION PULLEY	
23-2	076000800	1	タマジクウケ6000ZZ	BALL BEARING, 6000ZZ	
23-3	048260242	1	トメワアナヨウC26	RETAINING RING, C26	
23-4	S35287001	1	テンションブーリウデUクミ	TENSION PULLEY ARM (U) ASSY	
23-5	048100142	1	トメワジクヨウC10	RETAINING RING, C10	
24	018400832	2	アナボルト4X8	BOLT, SOCKET M4X8	
31	S35300000	1	タイミングベルトU	TIMING BELT (U)	
32	S35299000	1	タイミングベルトD	TIMING BELT (D)	
33	076001850	1	タマジクウケ6001ZZ	BALL BEARING, 6001ZZ	
34	142627001	1	ザガネ	WASHER	
35	S35302001	1	セットカラー	SET SCREW COLLAR	
36	014060632	2	アナトメ6X6クボミ	SET SCREW, SOCKET (CP) M6X6	
50	S43349000	1	パルスモータモーターコードR	PULSE MOTOR CORD (R)	
51	S35290001	2	テンションブーリ	SHOULDER SCREW, M4	
52	S36345000	2	ワッシャー	WASHER, SPRING	
53	S35297000	2	開閉シリンダ	OPENING CYLINDER STOPPER	
54	018401636	2	ボルト	BOLT, M4X14	
55	021400202	2	ナット	NUT, 2 M4	
56	S35288001	4	開閉シリンダ	OPENING STOPPER PLATE	
57	028040242	4	ワッシャー	WASHER, SPRING 2-4	
58	S35456001	2	サエモドシ	PRESSER SPRING	
59	S35457001	1	ネカケL	SPRING HOOK (L)	
60	S35458001	1	ネカケR	SPRING HOOK (R)	
61	S37093001	1	プレートガイド	PLATE GUIDE (C)	
62	S37744001	1	サエモドシ	PRESSER SPRING	
63	062400812	2	ボルト	SCREW, PAN M4X8	
64	S35323001	2	プレート	PLATE PRESSER	
65	S37714001	1	サブプレッサー	SUB PRESSER FULCRUM BRACKET	
66	S37713001	1	サブプレッサー	SUB PRESSER FULCRUM SHAFT	
67	048050142	2	リング	RETAINING RING, C5	
68	S37718000	1	サブプレッサー	SUB PRESSER ARM	
69	018401032	1	ボルト	BOLT, SOCKET M4X10	
70	S05356000	1	ボタン	BUTTON PRESSER, A	
71	S05356001	1	ストップネジ	STOPPER SCREW	
72	028050102	1	ナット	NUT, 1 SM3.18	
73	S37093001	1	サブプレッサー	SUB PRESSER SPRING	
74	S37717001	1	サブプレッサー	SUB PRESSER LINK ASSY	
75	S349221001	1	ボルト	SHOULDER SCREW, M4	
76	021400202	2	ナット	NUT, 2 M4	
77	S37093001	1	プレート	CLOTH GUIDE	

From the library of: Diamond Needle Corp

F. 押工関係 / Presser foot mechanism / Stoffdrückerfuß / Mécanisme de pied presseur /  
 Mecanismo de la prensa tela

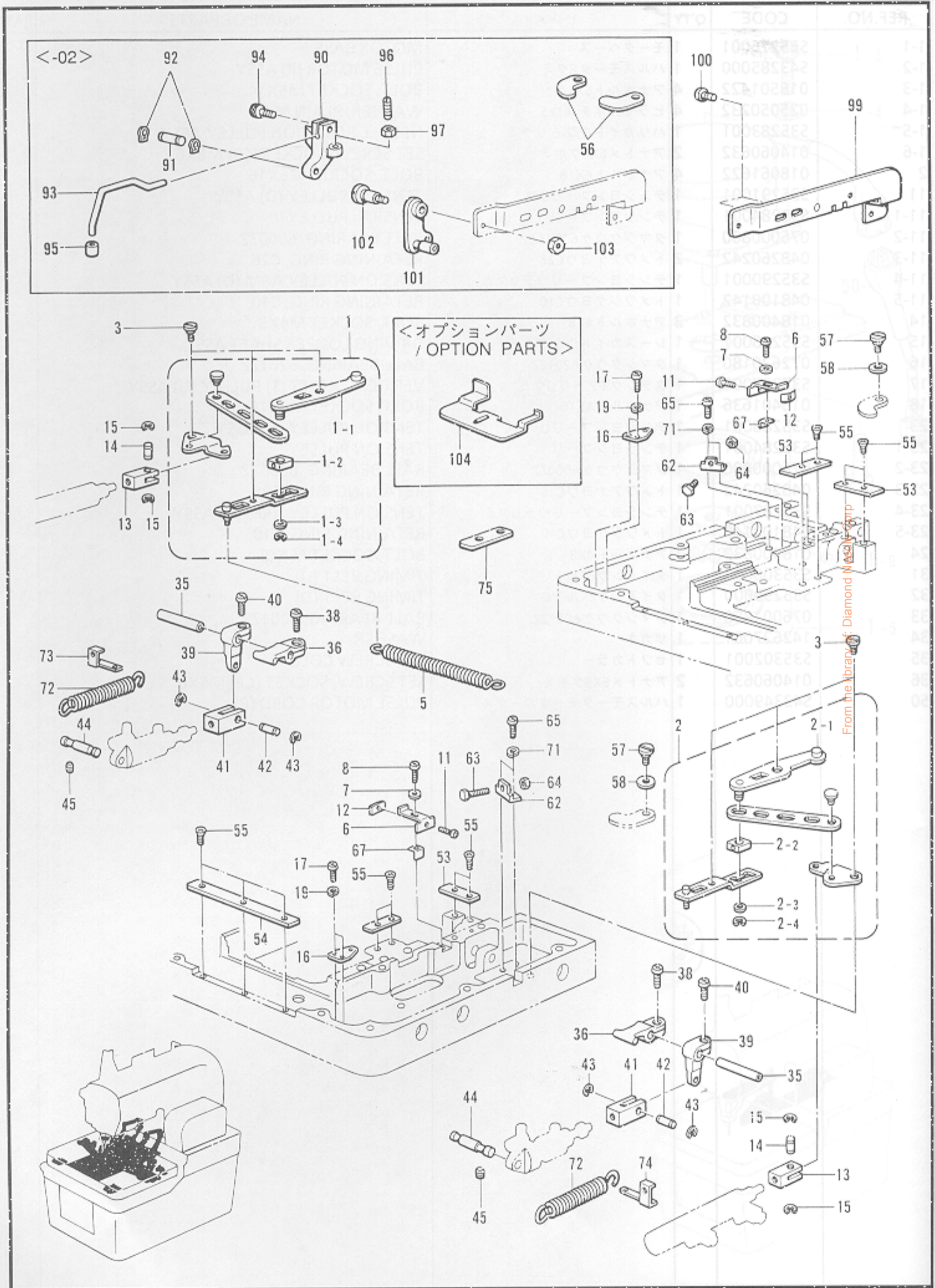

F. 押工関係 / Presser foot mechanism / Stoffdrückerfuß / Mécanisme de pied presseur / Mecanismo de la prensa tela

REF.NO.	CODE	Q'TY	ヒンメイ	NAME OF PARTS	RM
1	S34957001	1	ヒラキレンカンLクミ	OPENING CONNECTING ROD (L) ASSY	
1-1	S34965001	1	シテンレバープレートL	FULCRUM LEVER PLATE (R)	
1-2	102630001	1	ハリボウアンナイカクコマ	NEEDLE BAR GUIDE SLIDE BLOCK	
1-3	109763002	1	ザガネ	WASHER	
1-4	048050342	1	トメワE5	RETAINING RING, E5	
2	S34963001	1	ヒラキレンカンRクミ	OPENING CONNECTING ROD (R) ASSY	
2-1	S34964001	1	シテンレバープレートR	FULCRUM LEVER PLATE (L)	
2-2	102630001	1	ハリボウアンナイカクコマ	NEEDLE BAR GUIDE SLIDE BLOCK	
2-3	109763002	1	ザガネ	WASHER	
2-4	048050342	1	トメワE5	RETAINING RING, E5	
3	S34966001	6	ダンネジM4	SHOULDER SCREW, M4	
5	S35429001	1	ヒラキバネ	OPENING SPRING	
6	S34967001	2	ヒラキストツバイタ	OPENING STOPPER PLATE	
7	025040232	2	ヒラザガネチユウ4	WASHER, PLAIN M 4	
8	062400812	2	ナベコ4X8	SCREW, PAN M4X8	
11	062301016	2	ナベコM3X10	SCREW, PAN M3X10	
12	S34968000	2	スピードナツトM3	SPEED NUT, M3	
13	S34970001	2	ヒラキシリンダロツド	OPENING CYLINDER ROD	
14	S34969001	2	シリンダロツドピンB	CYLINDER ROD PIN (B)	
15	048030342	4	トメワE3	RETAINING RING, E3	
16	S35169001	2	ヒラキシリンダササエ	OPENING CYLINDER SUPPORT	
17	062400812	4	ナベコ4X8	SCREW, PAN M4X8	
19	028040242	4	バネザガネ2-4	WASHER, SPRING 2-4	
35	S35239001	2	クランプレバージク	CLAMP LEVER SHAFT	
36	S35240001	2	クランクレバーB	CLAMP LEVER (B)	
38	062501202	2	ナベコM5X12	SCREW, PAN M5X12	
39	S35303101	2	オサエクドウレバー	PRESSER DRIVING LEVER	
40	062501202	2	ナベコM5X12	SCREW, PAN M5X12	
41	S35166001	2	オサエシリンダロツド	PRESSER CYLINDER ROD	
42	S35305001	2	シリンダロツドピン	CYLINDER ROD PIN	
43	048030342	4	トメワE3	RETAINING RING, E3	
44	S35304001	2	クランプシリンダササエ	CLAMP CYLINDER SUPPORT	
45	014400532	2	アナクボミ4X5	SET SCREW, SOCKET (CP) M4X5	
53	S35321001	3	プレートガイドイタA	PLATE GUIDE (A)	
54	S35322001	1	プレートガイドイタB	PLATE GUIDE (B)	
55	S06696004	11	サラコネジ3X6	SCREW, FLAT M3X6	
57	S35324001	2	ダンネジM4	SHOULDER SCREW, M4	
58	S36345000	2	マゲワツツシャー	WASHER, SPRING	
62	S35327001	2	ヒラキシリンダストツバ	OPENING CYLINDER STOPPER	
63	017401415	2	ボルト4X14	BOLT, M4X14	
64	021400202	2	2シユナツト4	NUT, 2 M4	
65	062400812	4	ナベコ4X8	SCREW, PAN M4X8	
67	S35328001	2	ヒラキストツバアテイタ	OPENING STOPPER PLATE	
71	028040242	4	バネザガネ2-4	WASHER, SPRING 2-4	
72	S35456001	2	オサエモドシバネ	PRESSER SPRING	
73	S35457001	1	バネカケL	SPRING HOOK (L)	
74	S35458001	1	バネカケR	SPRING HOOK (R)	
75	S37693001	1	プレートガイドイタC	PLATE GUIDE (C)	
99	S37744001	1	Fオサエシリンダササエクミ	SUB PRESSER SYLINDER SUPPORT ASSY	
100	062400812	2	ナベコ4X8	SCREW, PAN M4X8	
<b>&lt;-02&gt;</b>					
56	S35323001	2	プレートオサエ	PLATE PRESSER	
90	S37714001	1	ホジヨオサエシテンダイ	SUB PRESSER FULCRUM BRACKET	
91	S37713001	1	ホジヨオサエシテンジク	SUB PRESSER FULCRUM SHAFT	
92	048050142	2	トメワジクヨウC5	RETAINING RING, C5	
93	S37718000	1	ホジヨオサエウデ	SUB PRESSER ARM	
94	018401032	1	アナボルト4X10	BOLT, SOCKET M4X10	
95	S05356000	1	ボタンオサエA	BUTTON PRESSER, A	
96	S08808001	1	ストツブネジ	STOPPER SCREW	
97	021660102	1	ナツト1シユ3.18	NUT, 1 SM3.18	
98	S37753001	1	ホジヨオサエモドシバネ	SUB PRESSER SPRING	
101	S37717001	1	ホジヨオサエリンククミ	SUB PRESSER LINK ASSY	
102	S34922101	1	ダンネジM4	SHOULDER SCREW, M4	
103	021400202	1	2シユナツト4	NUT, 2 M4	
<b>&lt;オプションパーツ/OPTION PARTS&gt;</b>					
104	S37870000	1	ヌノガイドJ	CLOTH GUIDE, J	

From the library of: Diamond Needle Corp

F. 押工関係 / Presser foot mechanism / Stoffdrückerfuß / Mécanisme de pied presseur /  
 Mecanismo de la prensa tela

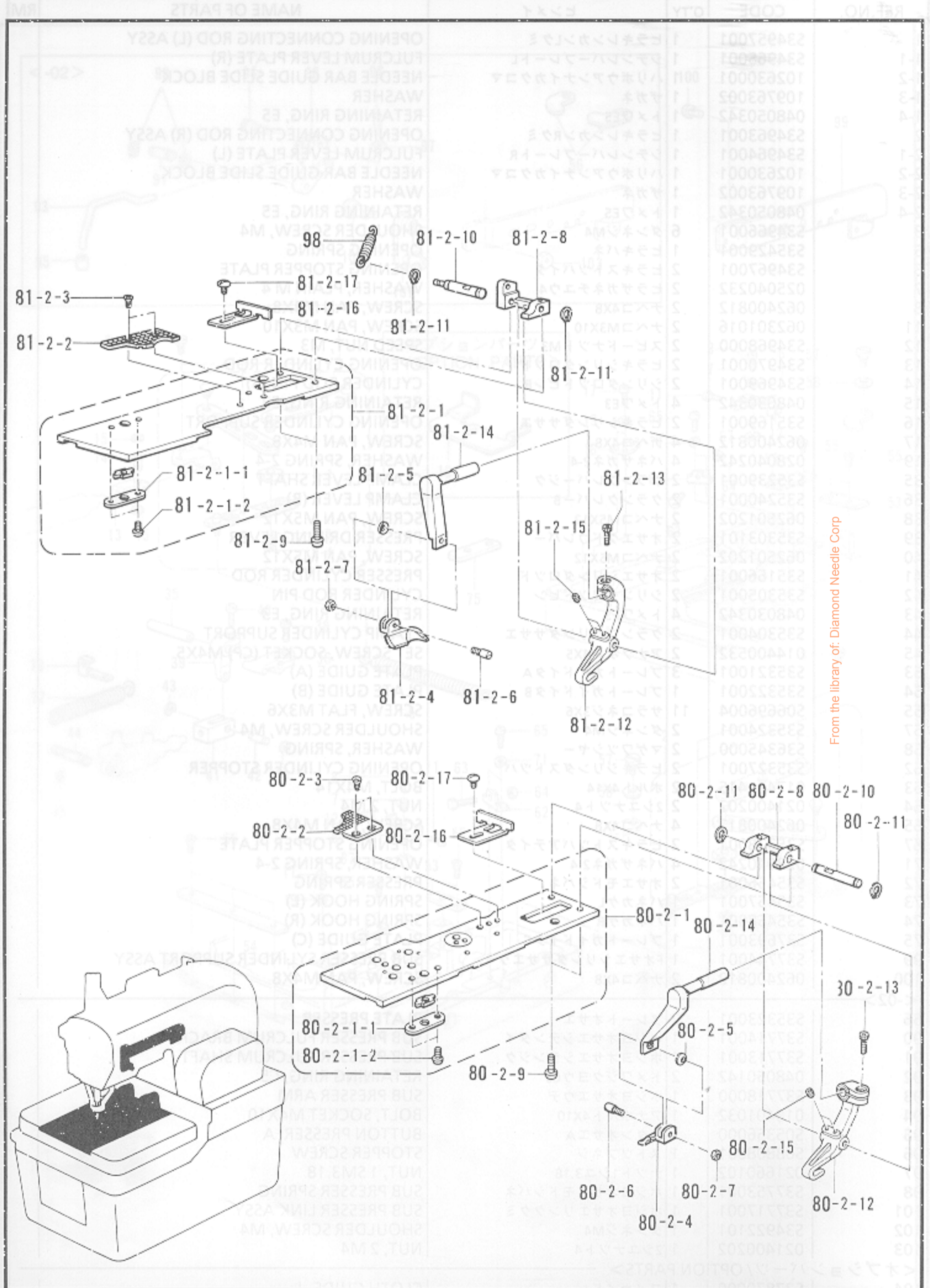

F. 押工関係 / Presser foot mechanism / Stoffdrückerfuß / Mécanisme de pied presseur / Mecanismo de la prensa tela

REF.NO.	CODE	Q'TY	ヒンメイ	NAME OF PARTS	RM
<b>&lt;L1 14 - 18mm&gt;</b>					
80-2	S37756401	1	オサエプレートJR1ソウクミ	CLOTH PRESSER PLATE (J)(R1) SET	
80-2-2	S37644101	1	ハリイタL1R	NEEDLE PLATE (L1)(R)	
80-2-4	S37754001	1	ヌノオサエR-JL1	CLOTH PRESSER (R-J)(L1)	※
<b>&lt;L2 18 - 22mm&gt;</b>					
80-2	S37727401	1	オサエプレートJR2ソウクミ	CLOTH PRESSER PLATE (J)(R2) SET	
80-2-2	S37646101	1	ハリイタL2R	NEEDLE PLATE (L2)(R)	
80-2-4	S37690001	1	ヌノオサエR-JL2	CLOTH PRESSER (R-J)(L2)	※
<b>&lt;L3 22 - 26mm&gt;</b>					
80-2	S37733401	1	オサエプレートJR3ソウクミ	CLOTH PRESSER PLATE (J)(R3) SET	
80-2-2	S37648101	1	ハリイタL3R	NEEDLE PLATE (L3)(R)	
80-2-4	S37692001	1	ヌノオサエR-JL3	CLOTH PRESSER (R-J)(L3)	※
<b>&lt;L4 26 - 30mm&gt;</b>					
80-2	S37757401	1	オサエプレートJR4ソウクミ	CLOTH PRESSER PLATE (J)(R4) SET	
80-2-2	S37650101	1	ハリイタL4R	NEEDLE PLATE (L4)(R)	
80-2-4	S37758001	1	ヌノオサエR-JL4	CLOTH PRESSER (R-J)(L4)	※
80-2-1	S37729101	1	ヌノオサエプレートJRクミ	CLOTH PRESSER PLATE(J)(R)ASSY	
80-2-1-1	S35316001	1	カクコマササエイタ	SLIDE BLOCK SUPPORT PLATE	
80-2-1-2	060020416	2	バインドM2X4	SCREW, BIND M2X4	
80-2-3	S06696004	2	サラコネジ3X6	SCREW, FLAT M3X6	
80-2-5	S35236000	1	マゲザガネ3.2	BENDING WASHER, M3.2	
80-2-6	S35235001	1	クランプササエピン	CLAMP SUPPORT PIN	
80-2-7	021300302	1	3シユナツト3	NUT, 3 M3	
80-2-8	S35238001	1	クランプジクウケ	CLAMP SHAFT HOLDER	
80-2-9	062401016	2	ナベコ4X10	SCREW, PAN M4X10	
80-2-10	S35237001	1	クランプシテンジク	CLAMP FULCRUM SHAFT	
80-2-11	048050142	2	トメワジクヨウC5	RETAINING RING, C5	
80-2-12	S35234201	1	クランプレバーR	CLAMP LEVER (R)	
80-2-13	018501236	1	アナボルト5X12	BOLT, SOCKET M5X12	
80-2-14	S37695001	1	クランプアームR-J	CLAMP ARM (R-J)	
80-2-15	014400532	2	アナクボミ4X5	SET SCREW, SOCKET (CP) M4X5	
80-2-16	S35347000	1	ヌノガイドR	CLOTH GUIDE (R)	
80-2-17	S35326001	1	シメネジM3.5	SCREW, M3.5	
<b>&lt;L1 14 - 18mm&gt;</b>					
81-2	S37731301	1	オサエプレートJL1ソウクミ	CLOTH PRESSER PLATE (J)(L1) SET	
81-2-2	S37643101	1	ハリイタL1L	NEEDLE PLATE (L1)(L)	
81-2-4	S37755001	1	ヌノオサエL-JL1	CLOTH PRESSER (L-J)(L1)	※
<b>&lt;L2 18 - 22mm&gt;</b>					
81-2	S37728301	1	オサエプレートJL2ソウクミ	CLOTH PRESSER PLATE (J)(L2) SET	
81-2-2	S37645101	1	ハリイタL2L	NEEDLE PLATE (L2)(L)	
81-2-4	S37689001	1	ヌノオサエL-JL2	CLOTH PRESSER (R-J)(L2)	※
<b>&lt;L3 22 - 26mm&gt;</b>					
81-2	S37735301	1	オサエプレートJL3ソウクミ	CLOTH PRESSER PLATE (J)(L3) SET	
81-2-2	S37647101	1	ハリイタL3L	NEEDLE PLATE (L3)(L)	
81-2-4	S37691001	1	ヌノオサエL-JL3	CLOTH PRESSER (L-J)(L3)	※
<b>&lt;L4 26 - 30mm&gt;</b>					
81-2	S37732301	1	オサエプレートJL4ソウクミ	CLOTH PRESSER PLATE (J)(L4) SET	
81-2-2	S37649101	1	ハリイタL4L	NEEDLE PLATE (L4)(L)	
81-2-4	S37759001	1	ヌノオサエL-JL4	CLOTH PRESSER (L-J)(L4)	※
81-2-1	S37730001	1	オサエプレートJLクミ	CLOTH PRESSER PLATE (J)(L) ASSY	
81-2-1-1	S35316001	1	カクコマササエイタ	SLIDE BLOCK SUPPORT PLATE	
81-2-1-2	060020416	2	バインドM2X4	SCREW, BIND M2X4	
81-2-3	S06696004	2	サラコネジ3X6	SCREW, FLAT M3X6	
81-2-5	S35236000	1	マゲザガネ3.2	BENDING WASHER, M3.2	
81-2-6	S35235001	1	クランプササエピン	CLAMP SUPPORT PIN	
81-2-7	021300302	1	3シユナツト3	NUT, 3 M3	
81-2-8	S37712001	1	クランプジクウケ	CLAMP SHAFT HOLDER	
81-2-9	062401016	2	ナベコ4X10	SCREW, PAN M4X10	
81-2-10	S37711001	1	クランプシテンジク	CLAMP FULCRUM SHAFT	
81-2-11	048050142	2	トメワジクヨウC5	RETAINING RING, C5	
81-2-12	S35233201	1	クランプレバーL	CLAMP LEVER (L)	
81-2-13	018501236	1	アナボルト5X12	BOLT, SOCKET M5X12	
81-2-14	S37694001	1	クランプアームL-J	CLAMP ARM (L-J)	
81-2-15	014400532	2	アナクボミ4X5	SET SCREW, SOCKET (CP) M4X5	
81-2-16	S35348000	1	ヌノガイドL	CLOTH GUIDE (L)	
81-2-17	S35326001	1	シメネジM3.5	SCREW, M3.5	

From the library of: Diamond Needle Corp

F. 押工関係 / Presser foot mechanism / Stoffdrückerfuß / Mécanisme de pied presseur / Mecanismo de la prensa tela

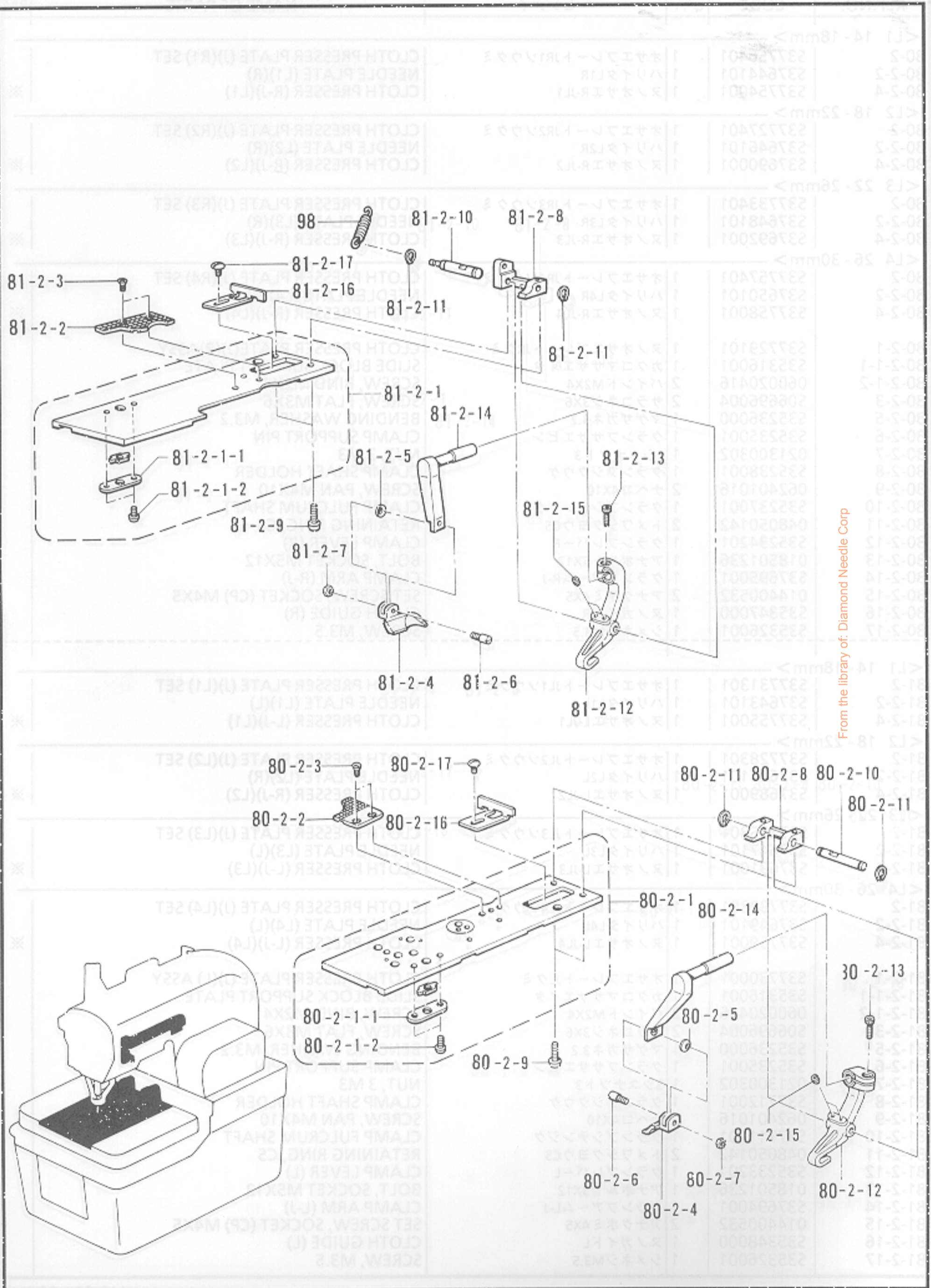

From the library of: Diamond Needle Corp

F. 押工関係 / Presser foot mechanism / Stoffdrückerfuß / Mécanisme de pied presseur / Mecanismo de la prensa tela

REF.NO.	CODE	Q'TY	ヒンメイ	NAME OF PARTS	RM
<L5 28-32mm>					
80-2	S40830101	1	オサエプレートJR5ソウクミ	CLOTH PRESSER PLATE (J)(R5) SET	
80-2-2	S40822001	1	ハリイタL5R	NEEDLE PLATE (L5)(R)	
80-2-4	S41483001	1	ヌノオサエR-JL5	CLOTH PRESSER, R-JL5	
<L6 32-36mm>					
80-2	S41489101	1	オサエプレートJR6ソウクミ	CLOTH PRESSER PLATE (J)(R6) SET	
80-2-2	S41479001	1	ハリイタL6R	NEEDLE PLATE (L6)(R)	
80-2-4	S41485001	1	ヌノオサエR-JL6	CLOTH PRESSER, R-JL6	
<L7 36-40mm>					
80-2	S41491101	1	オサエプレートJR7ソウクミ	CLOTH PRESSER PLATE (J)(R7) SET	
80-2-2	S41481001	1	ハリイタL7R	NEEDLE PLATE, L7R	
80-2-4	S41487001	1	ヌノオサエR-JL7	CLOTH PRESSER, R-JL7	
80-2-1	S40828001	1	ヌノオサエプレートJRクミB	CLOTH PRESSER PLATE (J)(R) ASSY, B	
80-2-1-1	S35316001	1	カクコマササエイタ	SLIDE BLOCK SUPPORT PLATE	
80-2-1-2	060020415	2	バインドM2X4	SCREW, BIND M2X4	
80-2-3	S06696004	2	サラコネジ3X6	SCREW, FLAT M3X6	
80-2-5	S35236000	1	マゲザガネ3.2	BENDING WASHER, M3.2	
80-2-6	S35235001	1	クランプササエピン	CLAMP SUPPORT PIN	
80-2-7	021300302	1	3シユナツト3	NUT, 3 M3	
80-2-8	S35238001	1	クランプジクウケ	CLAMP SHAFT HOLDER	
80-2-9	062401016	2	ナベコ4X10	SCREW, PAN M4X10	
80-2-10	S35237001	1	クランプシテンジク	CLAMP FULCRUM SHAFT	
80-2-11	048050142	2	トメワジクヨウC5	RETAINING RING, C5	
80-2-12	S35234201	1	クランプレバーR	CLAMP LEVER (R)	
80-2-13	018501236	1	アナボルト5X12	BOLT, SOCKET M5X12	
80-2-14	S40826001	1	クランプアームR-J-B	CLAMP ARM, R-J-B	
80-2-15	014400532	2	アナクボミ4X5	SET SCREW, SOCKET (CP) M4X5	
80-2-16	S35347000	1	ヌノガイドR	CLOTH GUIDE (R)	
80-2-17	S35326001	1	シメネジM3.5	SCREW, M3.5	
<L5 28-32mm>					
81-2	S40831101	1	オサエプレートJL5ソウクミ	CLOTH PRESSER PLATE (J)(L5) SET	
81-2-2	S40823001	1	ハリイタL5L	NEEDLE PLATE (L5)(L)	
81-2-4	S41484001	1	ヌノオサエL-JL5	CLOTH PRESSER, R-JL5	
<L6 32-36mm>					
81-2	S41490101	1	オサエプレートJL6ソウクミ	CLOTH PRESSER PLATE (J)(L6) SET	
81-2-2	S41480001	1	ハリイタL6L	NEEDLE PLATE (L6)(L)	
81-2-4	S41486001	1	ヌノオサエL-JL6	CLOTH PRESSER, L-JL6	
<L7 36-40mm>					
81-2	S41492101	1	オサエプレートJL7ソウクミ	CLOTH PRESSER PLATE (J)(L7) SET	
81-2-2	S41482001	1	ハリイタL7L	NEEDLE PLATE, L7L	
81-2-4	S41488001	1	ヌノオサエL-JL7	CLOTH PRESSER, L-JL7	
81-2-1	S35310001	1	ヌノオサエプレートLクミ	CLOTH PRESSER PLATE (L) ASSY	
81-2-1-1	S35316001	1	カクコマササエイタ	SLIDE BLOCK SUPPORT PLATE	
81-2-1-2	060020416	2	バインドM2X4	SCREW, BIND M2X4	
81-2-3	S06696004	2	サラコネジ3X6	SCREW, FLAT M3X6	
81-2-5	S35236000	1	マゲザガネ3.2	BENDING WASHER, M3.2	
81-2-6	S35235001	1	クランプササエピン	CLAMP SUPPORT PIN	
81-2-7	021300302	1	3シユナツト3	NUT, 3 M3	
81-2-8	S37712001	1	クランプジクウケ	CLAMP SHAFT HOLDER	
81-2-9	062401016	2	ナベコ4X10	SCREW, PAN M4X10	
81-2-10	S37711001	1	クランプシテンジク	CLAMP FULCRUM SHAFT	
81-2-11	048050142	2	トメワジクヨウC5	RETAINING RING, C5	
81-2-12	S35233201	1	クランプレバーL	CLAMP LEVER (L)	
81-2-13	018501236	1	アナボルト5X12	BOLT, SOCKET M5X12	
81-2-14	S40827001	1	クランプアームL-J-B	CLAMP ARM, L-J-B	
81-2-15	014400532	2	アナクボミ4X5	SET SCREW, SOCKET (CP) M4X5	
81-2-16	S35348000	1	ヌノガイドL	CLOTH GUIDE (L)	
81-2-17	S35326001	1	シメネジM3.5	SCREW, M3.5	

From the library of: Diamond Needle Corp



G. 送り関係 / Feed mechanism / Transportvorrichtung / Mécanisme de l'entraînement /  
 Mecanismo de la alimentación

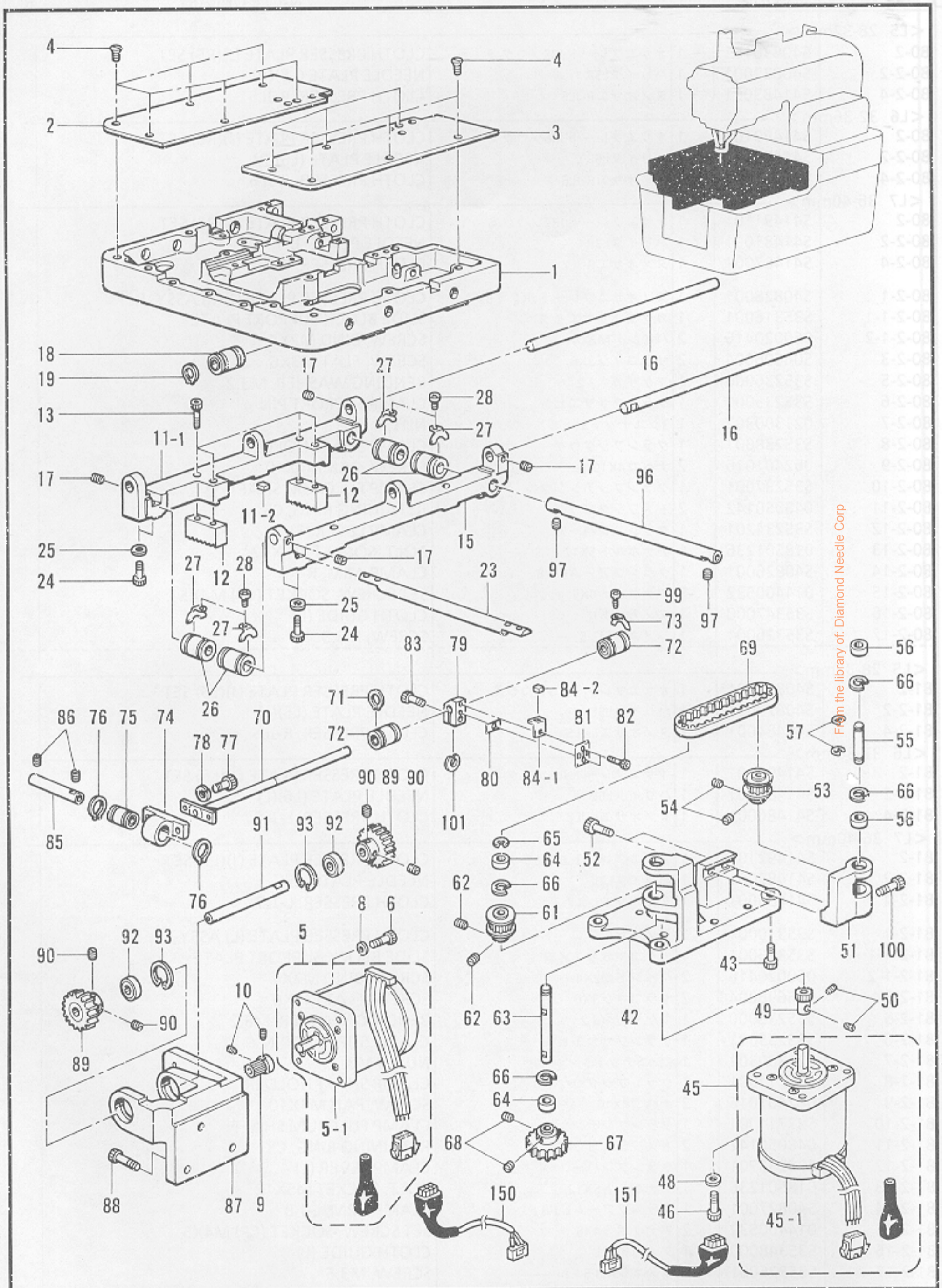

From the library of: Diamond Needle Corp

G. 送り関係 / Feed mechanism / Transportvorrichtung / Mécanisme de l'entraînement / Mecanismo de la alimentación

REF.NO.	CODE	Q'TY	ヒンメイ	NAME OF PARTS	RM
1	S34950109	1	オクリダイ	FEED BAR	
2	S35176001	1	オクリダイカバーL	FEED BRACKET COVER (L)	
3	S35177001	1	オクリダイカバーR	FEED BRACKET COVER (R)	
4	S29410001	12	サラネジM4	SCREW, FLAT M4	
5	S43192000	1	ハルスモータXクミ	PULSE MOTOR ASSY, X	
5-1	S43193000	1	ハルスモータ103H7523	PULSE MOTOR 103H7523	
6	018401622	4	アナボルト4X16	BOLT, SOCKET M4X16	
8	025040132	4	ヒラザガネシヨウ4	WASHER, PLAIN S 4	
9	S43717001	1	クドウギヤ15.75	ACTUATING GEAR 15.75	
10	014680622	2	アナトメネジ4.37クボミ	SET SCREW, SOCKET (CP) SM4.37	
11	S35181001	1	XオクリジクウケLクミ	X-FEED SHAFT HOLDER (L) ASSY	
11-1	S35180000	1	XオクリジクウケL	X-FEED SHAFT HOLDER (L)	
11-2	417526000	1	センサマグネット9	SENSOR MAGNET 9	
12	S35178001	2	Xラック	X-RACK	
13	018501631	4	アナボルト5X16	BOLT, SOCKET M5X16	
15	S35179000	1	XオクリジクウケR	X-FEED SHAFT HOLDER (R)	
16	S35188001	2	Yオクリアンナイジク	Y-FEED GUIDE SHAFT	
17	014060632	4	アナトメ6X6クボミ	SET SCREW, SOCKET (CP) M6X6	
18	S12004000	4	リニアブツシュ	LINEAR BUSH	
19	S02460001	8	トメワジクヨウC19	RETAINING RING, C19	
23	S35182001	1	XオクリアンナイジクA	X-FEED GUIDE SHAFT (A)	
24	018401636	4	アナボルト4X16	BOLT, SOCKET M4X16	
25	025040232	4	ヒラザガネチユウ4	WASHER, PLAIN M 4	
26	S35183000	4	リニアブツシュ12	LINEAR BUSH 12	
27	S35184001	4	タマジクウケトメイタ	BALL BEARING STOPPER	
28	062300416	4	ナベコM3X4	SCREW, PAN M3X4	
42	S43719001	1	YオクリベースB	Y-FEED BASE (B)	
43	018061622	4	アナボルト6X16	BOLT, SOCKET M6X16	
45	S43194000	1	ハルスモータYクミ	PULSE MOTOR ASSY, Y	
45-1	S43193000	1	ハルスモータ103H7523	PULSE MOTOR 103H7523	
46	018401622	4	アナボルト4X16	BOLT, SOCKET M4X16	
48	025040132	4	ヒラザガネシヨウ4	WASHER, PLAIN S 4	
49	S43718001	1	クドウギヤ25	DRIVING GEAR, 25	
50	014760622	2	アナトメネジ5.95	SET SCREW, SOCKET SM5.95	
51	S35174001	1	YプーリササエL	Y-PULLEY SUPPORT (L)	
52	018501422	2	アナボルト5X14	BOLT, SOCKET M5X14	
53	S27844101	1	タイミングプーリア	TIMING PULLEY, A	
54	014770622	2	アナトメネジ6.35クボミ	SET SCREW, SOCKET (CP) SM6.35	
55	S35186001	1	YプーリジクL	Y-PULLEY SHAFT (L)	
56	S30138001	2	マイクロベアリング8	MICRO BEARING, 8	
57	048060342	2	トメワE6	RETAINING RING, E6	
61	S27844101	1	タイミングプーリア	TIMING PULLEY, A	
62	014770622	2	アナトメネジ6.35クボミ	SET SCREW, SOCKET (CP) SM6.35	
63	S35189001	1	YプーリジクR	Y-PULLEY SHAFT (R)	
64	S30138001	2	マイクロベアリング8	MICRO BEARING, 8	
65	048060342	1	トメワE6	RETAINING RING, E6	
66	048160242	4	トメワアナヨウC16	RETAINING RING, C16	
67	S43720001	1	アイドルギヤ40	IDLE GEAR, 40	
68	014060632	2	アナトメ6X6クボミ	SET SCREW, SOCKET (CP) M6X6	
69	S10077100	1	Yタイミングベルト	Y-TIMING BELT	
70	S35190001	1	Yジク	Y-SHAFT	
71	S02460001	2	トメワジクヨウC19	RETAINING RING, C19	
72	S12004000	2	リニアブツシュ	LINEAR BUSH	
73	S35184001	1	タマジクウケトメイタ	BALL BEARING STOPPER	
74	S35191001	1	ジクウケ	BALL BEARING	
75	S12004000	1	リニアブツシュ	LINEAR BUSH	
76	S02460001	2	トメワジクヨウC19	RETAINING RING, C19	
77	018061022	2	アナボルト6X10	BOLT, SOCKET M6X10	
78	028060242	2	バネザガネ2-6	WASHER, SPRING 2-6	

From the library of: Diamond Needle Corp

G. 送り関係 / Feed mechanism / Transportvorrichtung / Mécanisme de l'entraînement / Mecanismo de la alimentación

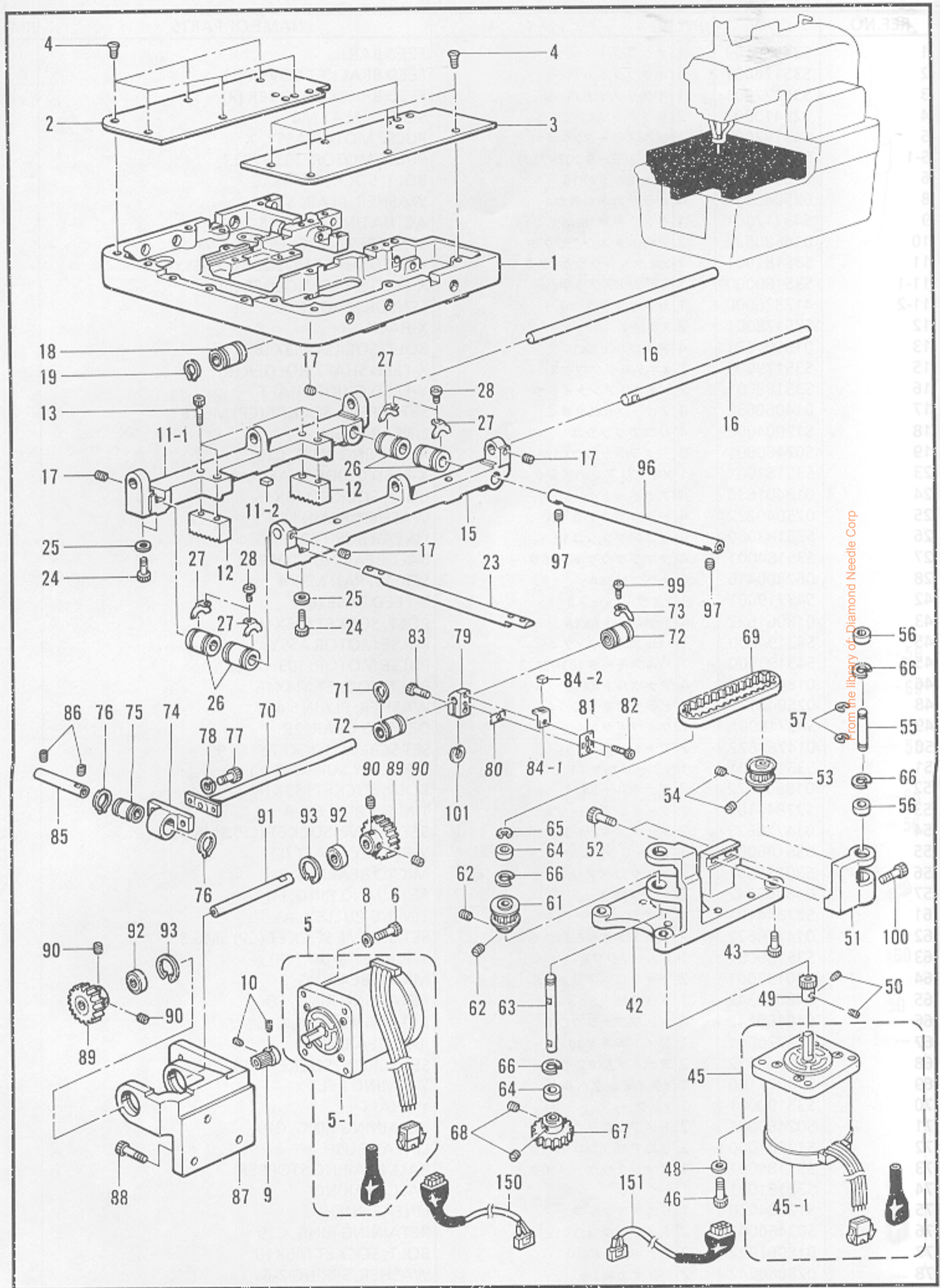

G. 送り関係 / Feed mechanism / Transportvorrichtung / Mécanisme de l'entraînement / Mecanismo de la alimentación

REF.NO.	CODE	Q'TY	ヒンメイ	NAME OF PARTS	RM
79	S31568000	1	Yクドウジクホルダ	Y-DRIVING SHAFT HOLDER	
80	S10078001	1	Tベルトスパーサ	TIMING BELT SPACER	
81	S10079001	1	ベルトホルダ	BELT HOLDER	
82	018680822	2	アナボルト4.37X8	BOLT, SOCKET SM4.37X8	
83	018501631	1	アナボルト5X16	BOLT, SOCKET M5X16	
84	S35192001	1	センサシキリイタクミ	SENSOR PARTITION PLATE ASSY	
84-1	S35193000	1	センサシキリイタ	SENSOR PARTITION PLATE	
84-2	128652001	1	マグネットREC16W	MAGNET REC16W	
85	S35194001	1	Yガイドジク	Y-GUIDE SHAFT	
86	012500536	2	アナヒラ5X5	SET SCREW, SOCKET (FT) M5X5	
87	S43749001	1	モータササエB	MOTOR SUPPORT, B	
88	018061622	3	アナボルト6X16	BOLT, SOCKET M6X16	
89	S35196100	2	アイドルギヤ	IDLE GEAR	
90	014060632	4	アナトメ6X6クボミ	SET SCREW, SOCKET (CP) M6X6	
91	S35195001	1	アイドルギヤジク	IDLE GEAR SHAFT	
92	076001800	2	タマジクウケ6001ZZ	BALL BEARING, 6001ZZ	
93	048280242	2	トメワアナヨウC28	RETAINING RING, C28	
96	S35187001	1	XオクリアンナイジクB	X-FEED GUIDE SHAFT (B)	
97	014060632	2	アナトメ6X6クボミ	SET SCREW, SOCKET (CP) M6X6	
99	062300416	1	ナベコM3X4	SCREW, PAN M3X4	
100	018502022	1	アナボルト5X20	BOLT, SOCKET M5X20	
101	148782001	1	スパーサ	SPACER	
150	S43347000	1	パルスモータモータコードX	PULSE MOTOR CORD (X)	
151	S43348000	1	パルスモータモータコードY	PULSE MOTOR CORD (Y)	
24		1	ハンマー	HAMMER	
25	S35473201	1	メスダイソウクミ	KNIFE BRACKET SET	
25-1	S35094201	1	メスダイソウクミ	KNIFE BRACKET ASSY	
25-2	S35097001	1	メスブロックオサエ	KNIFE BLOCK PRESSER	
25-3	018501632	1	アナボルト5X16	BOLT, SOCKET M5X16	
25-4	S35098000	1	ブロックストッパ	BLOCK STOPPER PLATE	
25-5	062300416	1	ナベコM3X4	SCREW, PAN M3X4	
26	018501222	1	アナボルト5X12	BOLT, SOCKET M5X12	
27	018062520	1	アナボルト6X25	BOLT, SOCKET M6X25	
34	S35437101	1	メス2.8X4.3-38	KNIFE, M2.8X4.3-38	
39	S35099001	1	メスブロックセンサーシキリイタ	CUTTER SENSOR PARTITION PLATE	
40	062400812	1	ナベコM4X8	SCREW, PAN M4X8	
45	S35078001	1	バネカケ	SPRING HOOK	
46	142640001	1	メスウチヨウセツササエ	SPRING, EXTENSION	
47	S35100001	1	メスウチヨウセツササエ	KNIFE ADJUST SUPPORT	
48	062400812	1	ナベコM4X8	SCREW, PAN M4X8	
51	S35101001	1	メスウチヨウセツササエ	KNIFE ADJUST SCREW	
52	S35102001	1	メスダイソウクミ	KNIFE BRACKET GUIDE	
53	018400832	3	アナボルト4X8	BOLT, SOCKET M4X8	
54	S35104001	1	メスパイプクミ	KNIFE PIPE ASSY	
55	062400812	2	ナベコM4X8	SCREW, PAN M4X8	
56	028040247	2	バネサガネ	WASHER, SPRING 2-4	

From the library of: Diamond Needle Corp

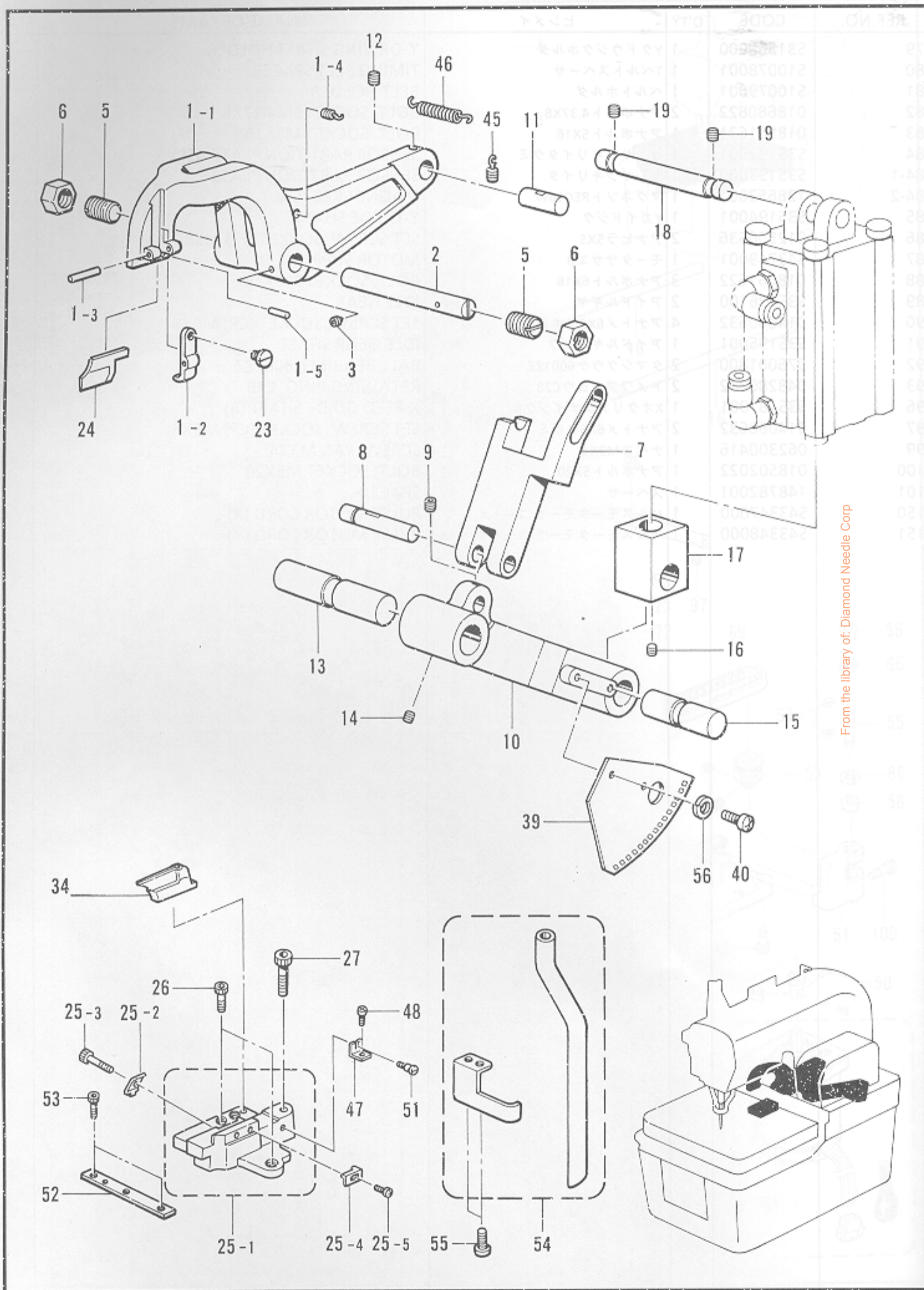

From the library of: Diamond Needle Corp

H. カッター関係 / Cutter mechanism / Abschneidevorrichtung / Mécanisme de la coupe / Mecanismo de la corta

REF.NO.	CODE	Q'TY	ヒンメイ	NAME OF PARTS	RM
1	S35074101	1	カッターウデクミ	CUTTER LEVER ASSY	
1-1	S35075101	1	カッターウデ	CUTTER LEVER	
1-2	S35076101	1	カッターカートリッジオサエ	CUTTER CARTRIDGE PRESSER	
1-3	S35077000	1	ニードルローラ4X25.8	NEEDLE ROLLER, M4X25.8	
1-4	S35078001	1	バネカケ	SPRING HOOK	
1-5	S35079000	1	ニードルローラ3X11.8	NEEDLE ROLLER, M3X11.8	
2	S35080001	1	カッターウデジク	CUTTER LEVER SHAFT	
3	016061031	1	アナトガリ 6X10	SET SCREW, SOCKET (CN) M6X10	
5	S35081001	2	カッターウデオサエネジ	CUTTER ARM SUPPORT SCREW	
6	S35082001	2	3シユナツト14	NUT, 3 M14	
7	S35088001	1	リンクA	LINK (A)	
8	S35085001	1	リンクジクC	LINK SHAFT (C)	
9	014060632	1	アナトメ6X6クボミ	SET SCREW, SOCKET (CP) M6X6	
10	S35087001	1	リンクC	LINK (C)	
11	S35086001	1	リンクジクB	LINK SHAFT (B)	
12	014060632	1	アナトメ6X6クボミ	SET SCREW, SOCKET (CP) M6X6	
13	S35083001	1	リンクジクA	LINK SHAFT (A)	
14	014060632	1	アナトメ6X6クボミ	SET SCREW, SOCKET (CP) M6X6	
15	S35084001	1	シリンダロツドジク	CYLINDER ROD SHAFT	
16	014060632	1	アナトメ6X6クボミ	SET SCREW, SOCKET (CP) M6X6	
17	S35089001	1	シリンダロツド	CYLINDER ROD	
18	S35090001	1	シリンダササエジク	CYLINDER SUPPORT SHAFT	
19	014060632	2	アナトメ6X6クボミ	SET SCREW, SOCKET (CP) M6X6	
23	S35091001	1	ツマミネジM5	KNOB SCREW, M5	
24	※	1	ハンマー	HAMMER	
25	S35473201	1	メスドダイソウクミ	KNIFE BRACKET SET	
25-1	S35094201	1	メスドダイクミ	KNIFE BRACKET ASSY	
25-2	S35097001	1	メスブロックオサエ	KNIFE BLOCK PRESSER	
25-3	018501622	1	アナボルト5X16	BOLT, SOCKET M5X16	
25-4	S35098000	1	ブロックストツパイタ	BLOCK STOPPER PLATE	
25-5	062300416	1	ナベコM3X4	SCREW, PAN M3X4	
26	018501222	2	アナボルト5X12	BOLT, SOCKET M5X12	
27	018062522	1	アナボルト6X25	BOLT, SOCKET M6X25	
34	S35437101	1	メス2.8X4.3-38	KNIFE, M2.8X4.3-38	
39	S35099001	1	カッターセンサーシキリイタ	CUTTER SENSOR PARTITION PLATE	
40	062400812	2	ナベコ4X8	SCREW, PAN M4X8	
45	S35078001	1	バネカケ	SPRING HOOK	
46	142642001	1	サドウチヨウセツキヒキバネ	SPRING, EXTENSION	
47	S35100001	1	メスチヨウセツササエ	KNIFE ADJUST SUPPORT	
48	062400812	1	ナベコ4X8	SCREW, PAN M4X8	
51	S35101001	1	メスチヨウセツネジ	KNIFE ADJUST SCREW	
52	S35102001	1	メスドダイアンナイ	KNIFE BRACKET GUIDE	
53	018400832	3	アナボルト4X8	BOLT, SOCKET M4X8	
54	S35104001	1	メスパイプクミ	KNIFE PIPE ASSY	
55	062400812	2	ナベコ4X8	SCREW, PAN M4X8	
56	028040242	2	バネザガネ2-4	WASHER, SPRING 2-4	
12-3	076001800	1	ボールベアリング6001ZZ	BALL BEARING, 6001ZZ	
12-4	048280242	2	リテーニングリングC28	RETAINING RING, C28	
12-5	048120142	1	リテーニングリングC12	RETAINING RING, C12	
16	018502036	1	アナボルト5X20	BOLT, SOCKET M5X20	
17	018502036	2	ワッシャーPLAIN M5	WASHER, PLAIN M5	

From the library of: Diamond Needle Corp

J. テンションプーリ関係 / Tension pulley mechanism / Spannrolle / Mécanisme de la poulie de tension / Mecanismo de la polea de tensión

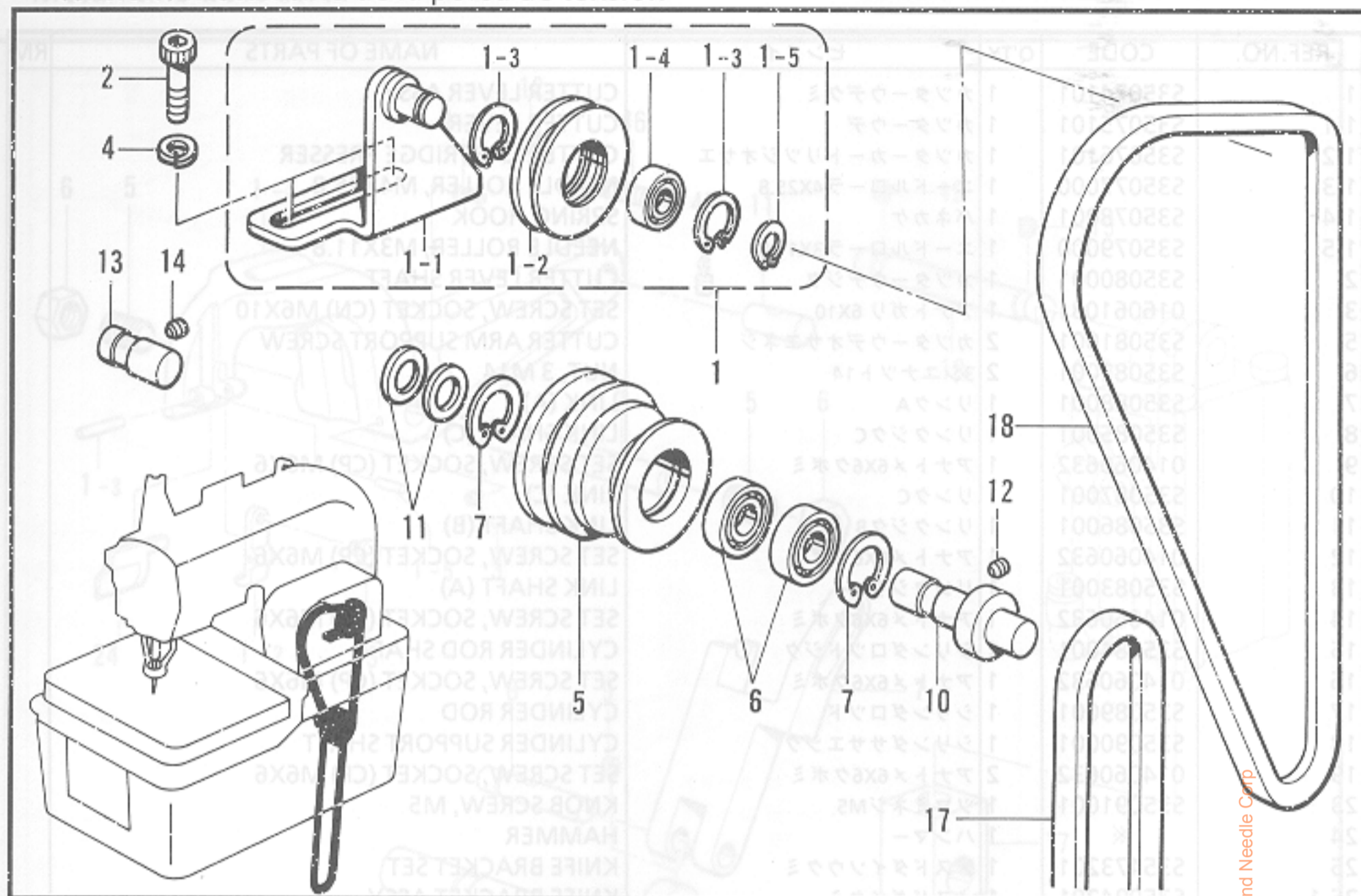

118-981-126

K. 下軸関係 / Lower shaft mechanism / Untere Welle / Mécanisme de l'arbre inférieur / Mecanismo del eje inferior

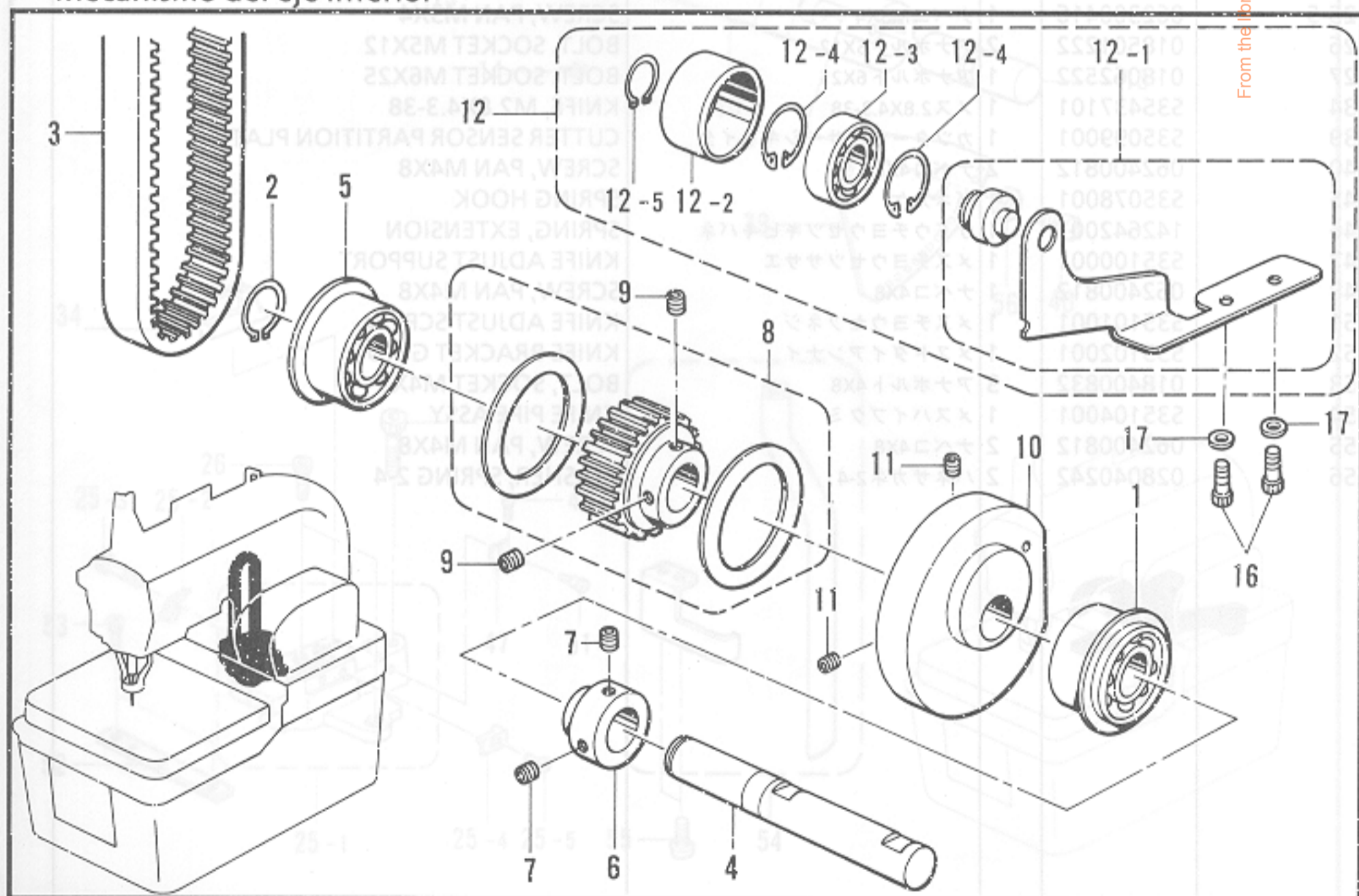

118-981-305

J. テンションプーリ関係 / Tension pulley mechanism / Spannrolle / Mécanisme de la poulie de tension / Mecanismo de la polea de tensión

REF.NO.	CODE	Q'TY	ヒンメイ	NAME OF PARTS	RM
1	S35112001	1	Tプーリクミ	TENSION PULLEY ASSY	
1-1	S35431001	1	Tプーリササエイタクミ	TENSION PULLEY SUPPORT PLATE ASSY	
1-2	S35110001	1	テンションプーリ	TENSION PULLEY	
1-3	048280242	2	トメワアナヨウC28	RETAINING RING, C28	
1-4	076001800	1	タマジクウケ6001ZZ	BALL BEARING, 6001ZZ	
1-5	048120142	1	トメワジクヨウC12	RETAINING RING, C12	
2	018081636	2	アナボルト8X16	BOLT, SOCKET M8X16	
4	028080242	2	バネザガネ2-8	WASHER, SPRING 2-8	
5	S35108001	1	アイドルプーリ	IDLER PULLEY	
6	076002800	2	タマジクウケ6002ZZ	BALL BEARING, 6002ZZ	
7	048320242	2	トメワアナヨウC32	RETAINING RING, C32	
10	S35107001	1	アイドルプーリジク	IDLER PULLEY SHAFT	
11	116920001	2	オクリジクスラストリング	THRUST RING	
12	014060632	1	アナトメ6X6クボミ	SET SCREW, SOCKET (CP) M6X6	
13	S35106001	1	ベッドササエジク	BED SUPPORT SHAFT	
14	014060632	1	アナトメ6X6クボミ	SET SCREW, SOCKET (CP) M6X6	
17	S18707129	1	VベルトMシロ (M29)	BELT, VM WHITE (M29)	
18	S18707137	1	VベルトMシロ (M36)	BELT, VM WHITE (M36)	
21	S35018001	1	カムリンクカラー	CAM LINK COLOR	
22	S35014001	1	ダンネジM4	STUD SCREW M4	
23	S35019001	1	ダンネジM4	STUD SCREW M4	
24	S35020001	2	スプレダーバネ	SPREADER SPRING	
25	S35021000	2	スプレダーバネアンナイ	SPREADER SPRING ANNAI	
26	S35022001	1	スプレダーサドカム	SPREADER SADDLE CAM	
27	S35023001	1	LSホルダーダイ	LS HOLDER DIE	
28	S35024001	1	アナトメネジ6X8クボミ	SET SCREW, SOCKET (CP) M6X8	
29	S35025001	1	ホルダーカム	HOLDER CAM	

118-981-126

K. 下軸関係 / Lower shaft mechanism / Untere Welle / Mécanisme de l'arbre inférieur / Mecanismo del eje inferior

REF.NO.	CODE	Q'TY	ヒンメイ	NAME OF PARTS	RM
1	076003850	1	タマジクウケ6003ZZ	BALL BEARING, 6003ZZ	
2	048150142	1	トメワジクヨウC15	RETAINING RING, C15	
3	S35275000	1	タイミングベルト665	TIMING BELT, 665	
4	S35273001	1	シタジクカムジク	CAM SHAFT	
5	076202850	1	タマジクウケ6202ZZ	BALL BEARING, 6202ZZ	
6	S35274001	1	セットカラー	SET SCREW COLLAR	
7	S23651001	2	アナヒラ6X6ホソメ	SET SCREW, SOCKET (FT) M6X6	
8	S35272001	1	シタジクTプーリクミ	LOWER SHAFT TENSION PULLEY ASSY	
9	S23651001	2	アナヒラ6X6ホソメ	SET SCREW, SOCKET (FT) M6X6	
10	S35270001	1	シタジクカム	LOWER SHAFT CAM	
11	S23651001	2	アナヒラ6X6ホソメ	SET SCREW, SOCKET (FT) M6X6	
12	S35269001	1	テンションプーリクミ	TENSION PULLEY ASSY	
12-1	S35268001	1	テンションプーリウデクミ	TENSION PULLEY ARM ASSY	
12-2	S35265001	1	テンションプーリ	TENSION PULLEY	
12-3	076001800	1	タマジクウケ6001ZZ	BALL BEARING, 6001ZZ	
12-4	048280242	2	トメワアナヨウC28	RETAINING RING, C28	
12-5	048120142	1	トメワジクヨウC12	RETAINING RING, C12	
16	018502036	2	アナボルト5X20	BOLT, SOCKET M5X20	
17	025050232	2	ヒラザガネチユウ5	WASHER, PLAIN M 5	
57	021400202	1	ナットM4	NUT M4	
58	S25038001	1	イトトリバネ	THREAD TAKE-UP SPRING	
59	S35280000	1	イトトリバネササエ	L-THREAD TAKE-UP SPRING SUPPORT	
60	S350300416	1	ビスM3X4	SCREW, BIND M3X4	
61	S35040000	1	イトトリバネアンナイ	L-THREAD TAKE-UP SPRING GUIDE	
62	S35018001	1	カムリンクカラー	CAM LINK COLOR	
63	062401416	1	ナベコ4X14	SCREW, PAN M4X14	
64	S35041000	1	イトトリバネ	THREAD SUPPORT PLATE	

118-981-305



L. 二重環ルーパ関係 / Double chain stitch looper mechanism / Doppelkettenstichgreifer /  
 Mécanisme du boucleur pour point de chaînette double / Mecanismo del presilladora de  
 double cadeneta

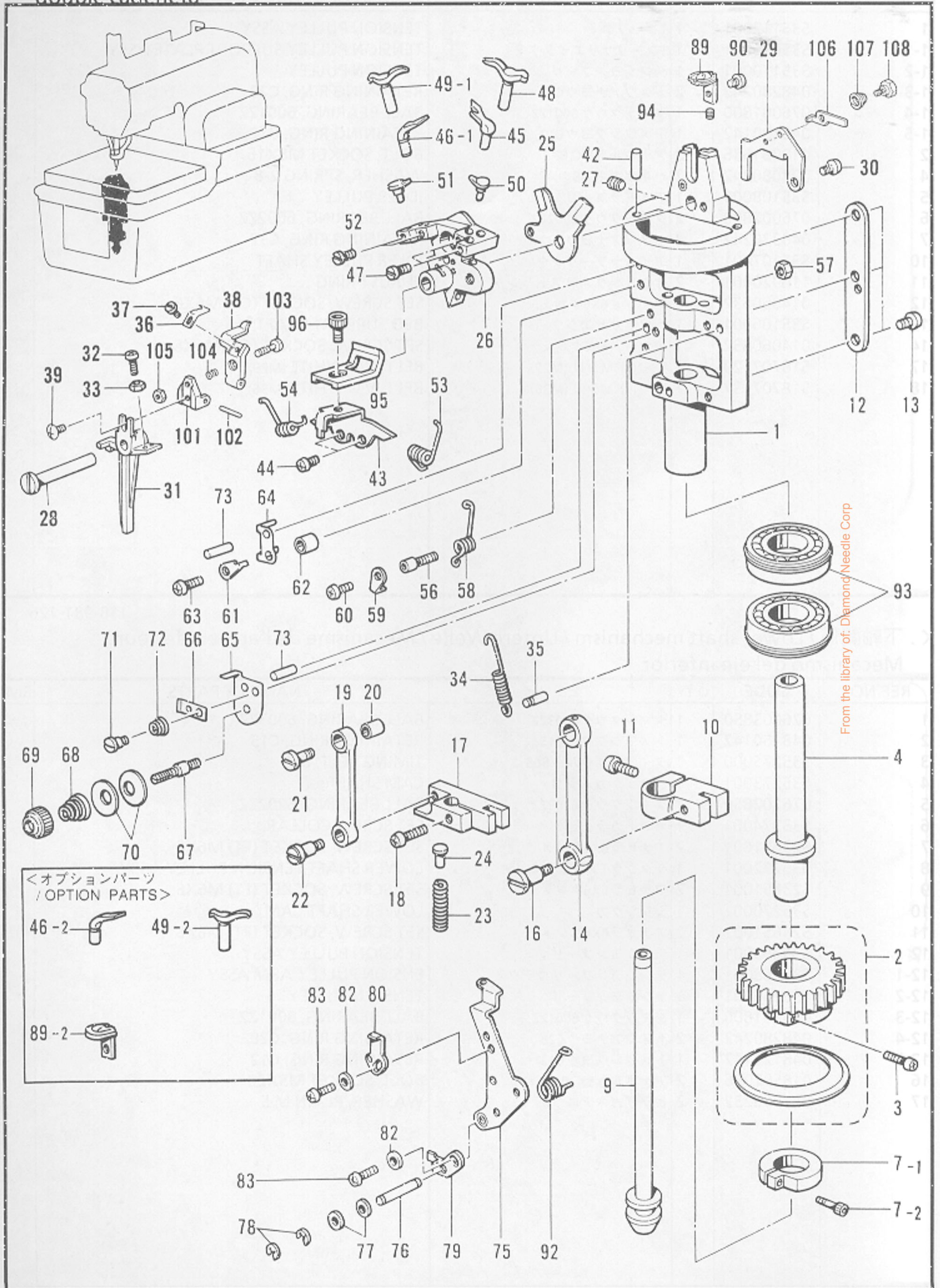

From the library of: Diamond Needle Corp

L. 二重環ルーパ関係 / Double chain stitch looper mechanism / Doppelkettenstichgreifer /  
 Mécanisme du boucleur pour point de chaînette double /  
 Mecanismo del presilladora de double cadeneta

REF.NO.	CODE	Q'TY	ヒンメイ	NAME OF PARTS	RM
1	S34948101	1	レースドダイ	LOOPER BASE	
2	S35007000	1	レースプーリクミ	LOOPER PULLEY ASSY	
3	062351615	1	ナベコ35X16	SCREW, PAN M35X16	
4	S35010001	1	ルーバークドウジク	LOOPER DRIVING SHAFT	
7	S37432001	1	ハリボウブロックダキクミ	NEEDLE BAR BLOCK CLAMP ASSY	
7-1	S35143001	1	ハリボウブロックダキ	NEEDLE BAR BLOCK CLAMP	
7-2	018301632	1	アナボルト3X16	BOLT, SOCKET M3X16	
9	S35053001	1	スプレダーリンクジク	SPREADER LINK SHAFT	
10	S35011001	1	ルーバークリンクシテン	LOOPER LINK CLAMP	
11	062501202	1	ナベコM5X12	SCREW, PAN M5X12	
12	S35012001	1	LSスライドアンナイ	LS-SLIDE GUIDE	
13	062300612	3	ナベコ3X6	SCREW, PAN M3X6	
14	S35015001	1	ルーバークリンク	LOOPER LINK	
16	S35013001	2	ダンネジM4	STUD SCREW, M4	
17	S35016001	1	スプレダーリンクダイ	SPREADER LINK BASE	
18	062501202	1	ナベコM5X12	SCREW, PAN M5X12	
19	S35017001	1	スプレダーカムリンク	SPREADER CAM LINK	
20	S35018001	1	カムリンクカラー	CAM LINK COLLAR	
21	S35014001	1	ダンネジM4	STUD SCREW, M4	
22	S35019001	1	ダンネジM4	STUD SCREW, M4	
23	S35020001	2	スプレダーバネ	SPREADER SPRING	
24	S35021000	2	スプレダーバネアンナイ	SPREADER SPRING GUIDE	
25	S35022001	1	スプレダーサドウカム	SPREADER DIFFERENTIAL CAM	
26	S35023001	1	LSホルダーダダイ	LS-HOLDER BRACKET	
27	014060832	1	アナトメネジ6X8クボミ	SET SCREW, SOCKET (CP) M6X8	
28	S35024101	1	ホルダーササエジク	HOLDER SUPPORT SHAFT	
29	S37696001	1	シンイトアンナイC-J	GIMP GUIDE (C-J)	
30	060400516	1	バインドM4X5	SCREW, BIND M4X5	
31	S37726001	1	イトキリレバードダイB	THREAD TRIMMER LEVER BRACKET (B)	
32	062301016	1	ナベコM3X10	SCREW, PAN M3X10	
33	021300302	1	3シユナツト3	NUT, 3 M3	
34	S35027001	1	Uイトキリバネ	U-THREAD TRIMMER SPRING	
35	S35028000	1	ダウエルピン3X16	DOWEL PIN, M3X16	
36	S37723001	1	ウワイドウハB	UPPER MOVABLE KNIFE (B)	
37	105288001	1	シメネジ2.38	SCREW, M2.38	
38	S37720001	1	シタイトオサエ	LOWER THREAD PRESSER	
39	060350616	1	バインド3.5X6	SCREW, BIND M3.5X6	
42	S35030001	1	イトアンナイパイプ	THREAD GUIDE PIPE	
43	S36660001	1	ハリウケササエ	NEEDLE GUARD SUPPORT	
44	062300612	2	ナベコ3X6	SCREW, PAN M3X6	
45	S35410001	1	ルーバーク	LOOPER (R)	
46-1	S35411001	1	アイルーバーク	EYE LOOPER	
47	S35032101	2	シメネジ2.6X5.5	SCREW, M2.6X5.5	
48	S35412001	1	スプレダーR	SPREADER (R)	
49-1	S35413001	1	スプレダーL	SPREADER (L)	
50	S35034001	1	スプレダーストツパR	SPREADER STOPPER (R)	
51	S35033001	1	スプレダーストツパL	SPREADER STOPPER (L)	
52	S35032101	2	シメネジ2.6X5.5	SCREW, M2.6X5.5	
53	S35035001	1	スプレダーバネR	SPREADER SPRING (R)	
54	S35036001	1	スプレダーバネL	SPREADER SPRING (L)	
56	S35037001	1	バネアンナイジク	SPRING GUIDE SHAFT	
57	021400202	1	2シユナツト4	NUT, 2 M4	
58	S35038001	1	イトトリバネ	THREAD TAKE-UP SPRING	
59	S35039000	1	イトトリバネササエ	L-THREAD TAKE-UP SPRING SUPPORT	
60	060300416	1	バインド3X4	SCREW, BIND M3X4	
61	S35040000	1	イトトリバネアンナイ	L-THREAD TAKE-UP SPRING GUIDE	
62	S35018001	1	カムリンクカラー	CAM LINK COLLAR	
63	062401416	1	ナベコ4X14	SCREW, PAN M4X14	
64	S35041000	1	イトササエイタ	THREAD SUPPORT PLATE	

From the library of: Diamond Needle Corp

L. 二重環ルーパ関係 / Double chain stitch looper mechanism / Doppelkettenstichgreifer /  
 Mécanisme du boucleur pour point de chaînette double / Mecanismo del presilladora de  
 double cadeneta

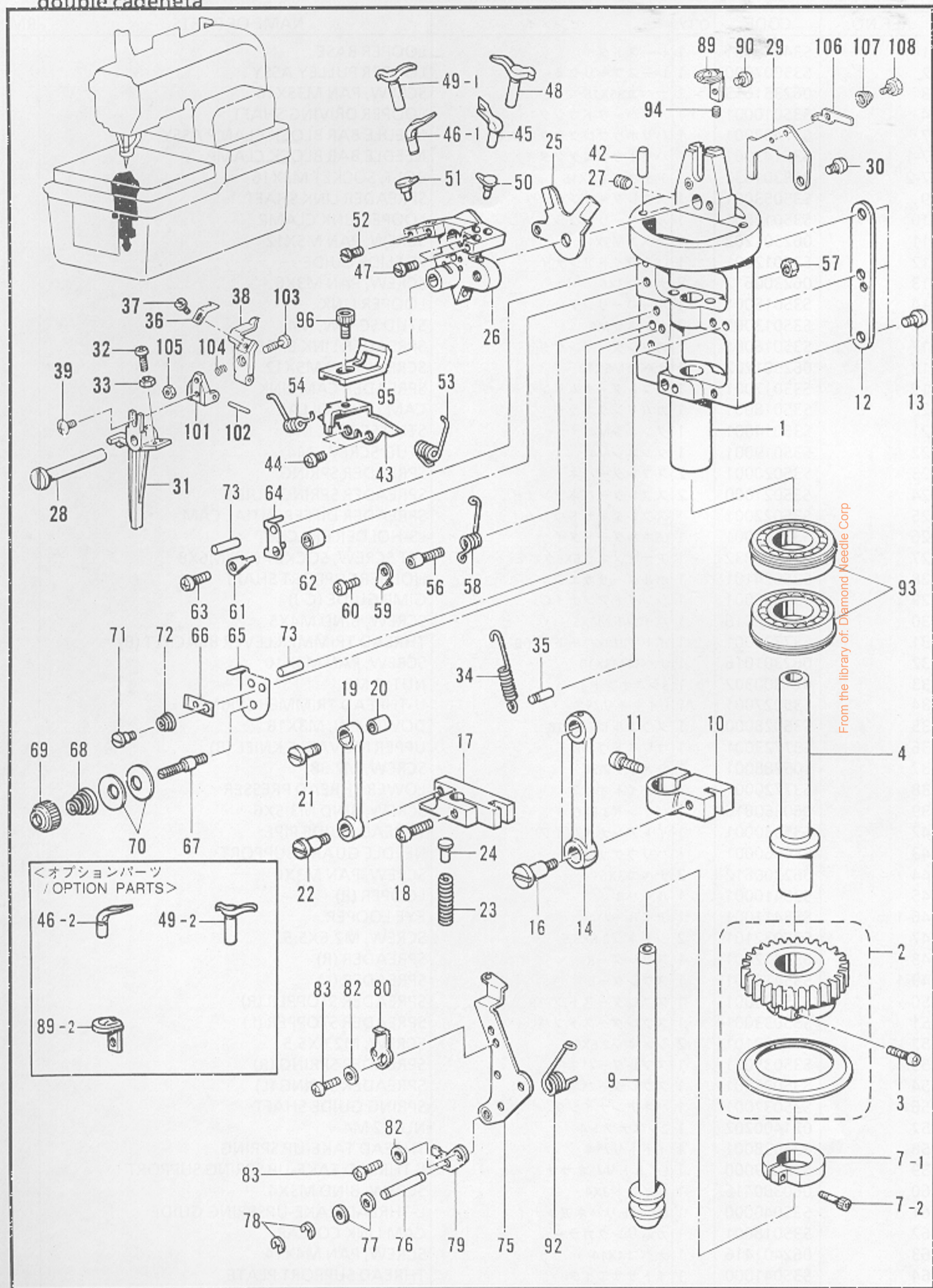

L. 二重環ルーパ関係 / Double chain stitch looper mechanism / Doppelkettenstichgreifer /  
 Mécanisme du boucleur pour point de chaînette double /  
 Mecanismo del presilladora de double cadeneta

REF.NO.	CODE	QTY	ヒンメイ	NAME OF PARTS	RM
65	S35043001	1	ライトオサエダイ	L-THREAD PRESSER BASE	
66	S35042000	1	ライトオサエ	L-THREAD PRESSER	
67	S35044001	1	ライトチョウシボウ	L-TENSION STUD	
68	154562001	1	プレテンションバネB	PRE-TENSION SPRING (B)	
69	155510001	1	イトチョウシナツト	TENSION NUT	
70	144504001	2	イトアンナイサラ	THREAD GUIDE DISC	
71	S35045001	1	ダンネジM3	STUD SCREW, M3	
72	S35118001	1	ハリイトチョウシバネ	TENSION SPRING	
73	S35046000	2	ニードルピン3X17.8	NEEDLE PIN, M3X17.8	
75	S35048101	1	イトユルメレバー	TENSION RELEASE LEVER	
76	S35049001	1	イトユルメレバージク	TENSION RELEASE LEVER SHAFT	
77	025680132	2	ヒラザガネシヨウ4.37	WASHER, PLAIN S 4.37	
78	048030342	2	トメワE3	RETAINING RING, E3	
79	S35050001	1	ルーバーイトユルメ	LOOPER TENSION RELEASE	
80	S35051001	1	イトユルメチヨウセツイタ	TENSION RELEASE PLATE	
82	025350236	2	ヒラザガネチユウ3.5	WASHER, PLAIN M 3.5	
83	062350516	2	ナベコ3.5X5	SCREW, PAN M3.5X5	
89	S37752001	1	スロートプレート1.8-J	THROAT PLATE 1.8(J)	
90	S35326001	1	シメネジM3.5	SCREW, M3.5	
92	S35057001	1	イトユルメレバーバネ	THREAD RELEASE LEVER SPRING	
93	076003850	2	タマジクウケ6003ZZ	BALL BEARING, 6003ZZ	
94	014300832	1	アナクボミM3X8	SET SCREW, SOCKET (CP) M3X8	
95	S36659001	1	ハリウケU	NEEDLE GUARD (U)	
96	018300532	1	アナボルト3X5	BOLT, SOCKET M3X5	
101	S37721001	1	シタイトオサエダイ	LOWER THREAD PRESSER BRACKET	
102	148407001	1	ヨコアンナイミゾピンL	DOWEL PIN (L)	
103	S37724001	1	シメネジ2.38	SCREW, M2.38	
104	S37725001	1	シタイトオサエバネ	LOWER THREAD PRESSER SPRING	
105	021630102	1	ナツト1シユ2.	NUT, 1 M2	
106	S41252000	1	シンイトオサエイター-J	GIMP THREAD WORK CLAMP -J	
107	S35118001	1	ハリイトチョウシバネ	TENSION SPRING	
108	159113001	1	ダンネジ3.18	SHOULDER SCREW, SM3.18	
<b>&lt;オプションパーツ / OPTION PARTS &gt;</b>					
<b>&lt;太糸用 / FOR HEAVY &gt;</b>					
46-2	S35471001	1	アイルーパB	EYE LOOPER (B)	
49-2	S35472001	1	スプレダーLB	SPREADER (LB)	
<b>&lt;かがり幅大 / FOR WIDE STITCH WIDTH &gt;</b>					
89-2	S35392001	1	スロートプレート1.8	THROAT PLATE (1.8)	
89-2	S35391001	1	スロートプレート2.5	THROAT PLATE (2.5)	
<b>&lt;かがり幅中小 / FOR NARROW STITCH WIDTH &gt;</b>					
89-2	S38888001	1	スロートプレート0.8	THROAT PLATE (0.8)	
9	S23612001		イトカラーグミ	SET SCREW COLLAR	
10	014060632		×6X67ボシ	SCREW, SOCKET (CP) M6X6	

From the library of: Diamond Needle Corp

M. ルーパー関係 / Looper mechanism / Greifer / Mécanisme des griffes / Mecanismo del presilladora

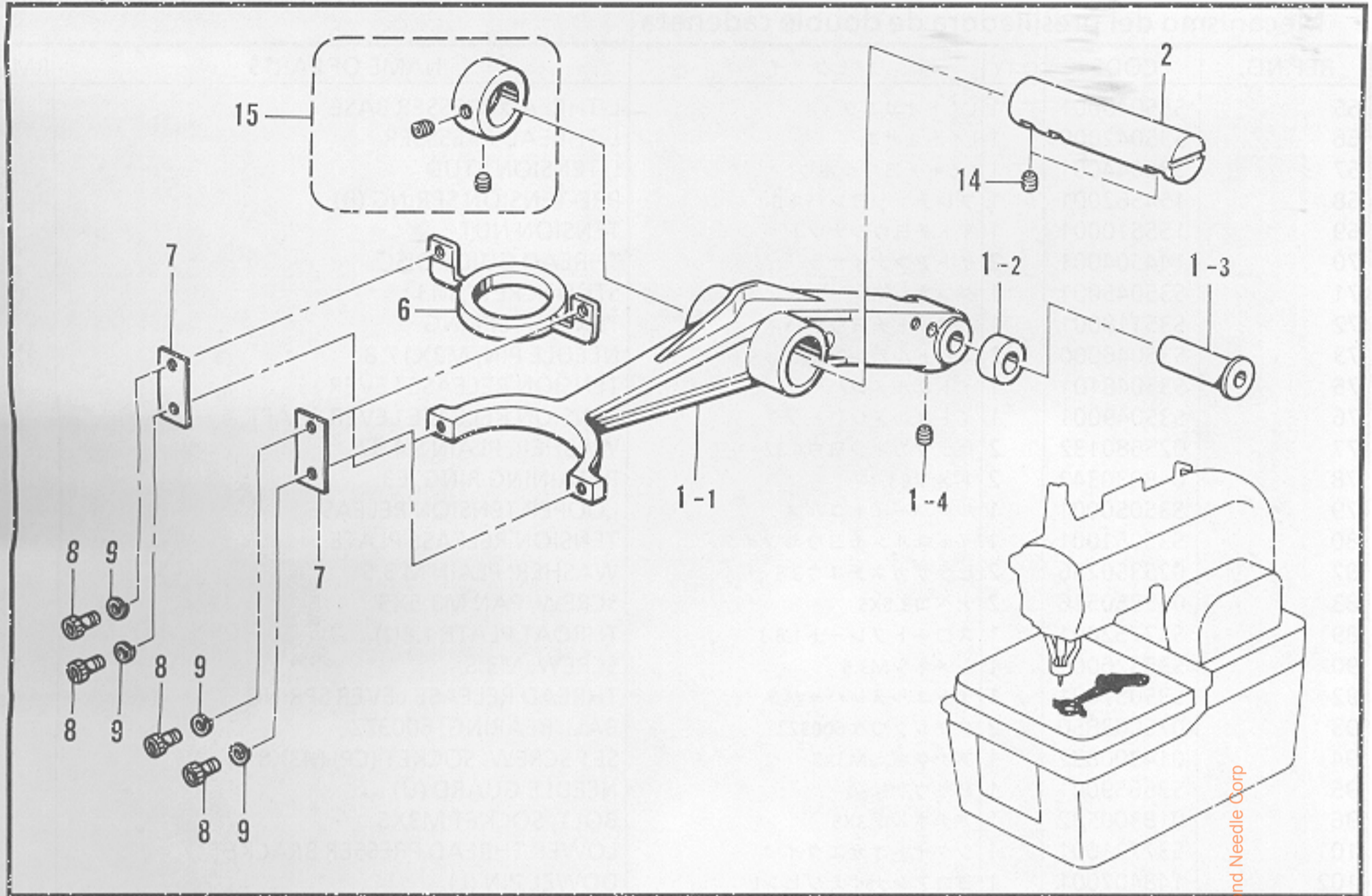

118-981-306

N. スプレダー関係 / Spreader mechanism / Spreizvorrichtung / Mécanisme de l'étendeur / Mecanismo extendedor

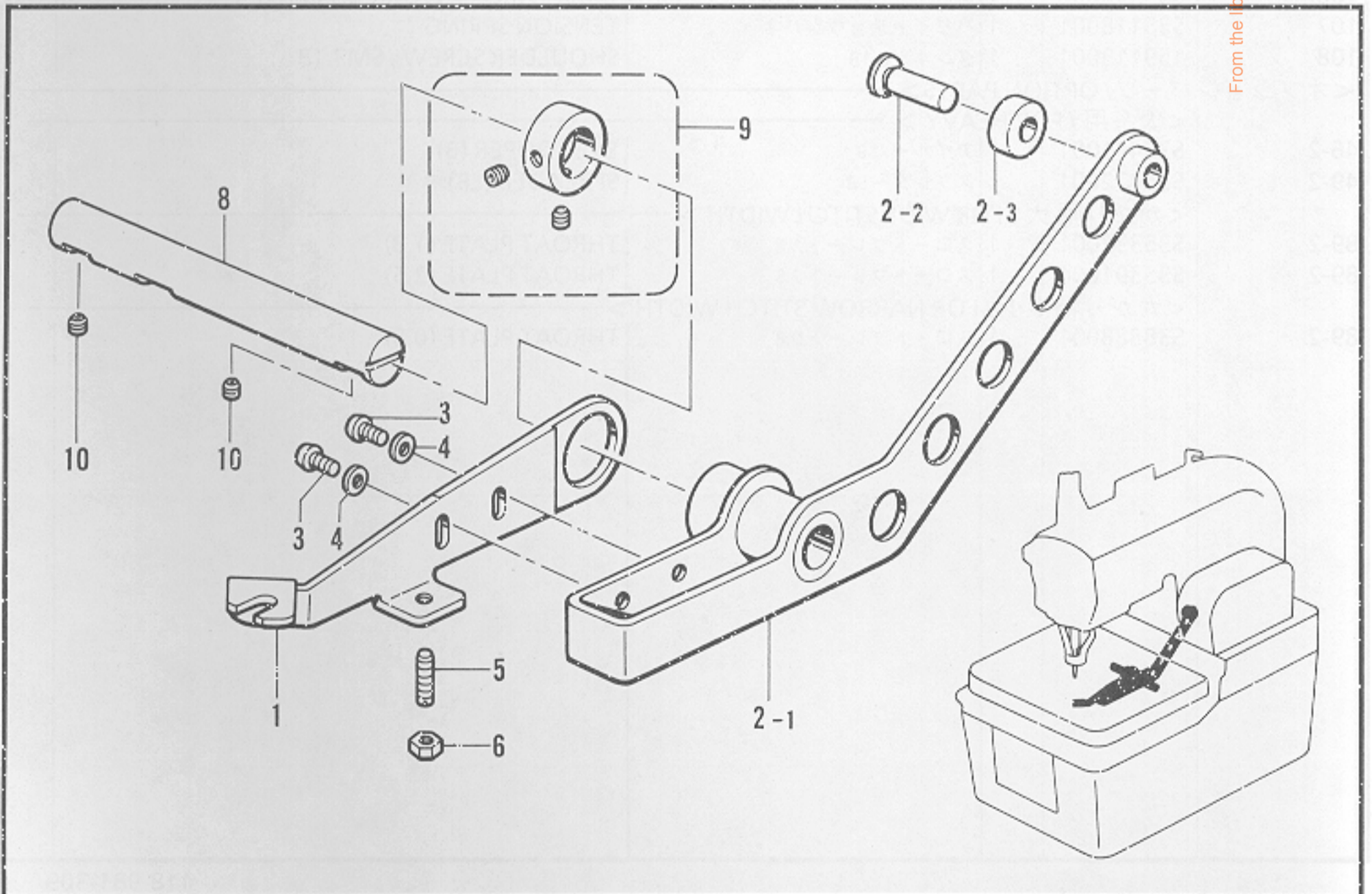

118-981-310

From the library of Diamond Needle Corp

M. ルーパー関係 / Looper mechanism / Greifer / Mécanisme des griffes / Mecanismo del presilladora

REF.NO.	CODE	Q'TY	ヒンメイ	NAME OF PARTS	RM
1	S35066001	1	ルーパーリンククミ	LOOPER LINK ASSY	
1-1	S35067001	1	ルーパーリンク	LOOPER LINK	
1-2	S35063001	1	ルーパーカムコロ	LOOPER CAM ROLLER	
1-3	S35064001	1	ルーパーカムコロピン	LOOPER CAM ROLLER PIN	
1-4	014060632	1	アナトメ6X6クボミ	SET SCREW, SOCKET (CP) M6X6	
2	S35065001	1	ルーパーリンクササエジク	LOOPER LINK SUPPORT SHAFT	
6	S35062001	1	ルーパーサドウタイ	LOOPER DRIVING PLATE	
7	S35061000	2	ルーパーリンクバネ	LOOPER LINK SPRING	
8	S10439001	4	アナボルト3X6	BOLT, SOCKET M3	
9	028030242	4	バネザガネ2-3	WASHER, SPRING 2-3	
14	014060632	2	アナトメ6X6クボミ	SET SCREW, SOCKET (CP) M6X6	
15	S23612001	1	セットカラークミ	SET SCREW COLLAR ASSY	
2	062300416	1	ナベコM3X4	SCREW, PAN M3X4	
3	S34996001	1	フエルト	FELT SUPPORT	
4	113006001	2	フエルト	FELT	
5	S34995000	1	フエルト(A)	FELT (A)	
7	062300416	1	ナベコM3X4	SCREW, PAN M3X4	
7	S34986000	1	ビニルチューブ	OIL TUBE (L=135)	
8	S34985000	1	ビニルチューブ	OIL TUBE (L=87)	
9	S34984000	1	ビニルチューブ	OIL TUBE (L=100)	
10	S34983000	1	ビニルチューブ	OIL TUBE (L=160)	
11	S34982000	1	ビニルチューブ	OIL TUBE (L=70)	
12	S34981000	1	ビニルチューブ	OIL TUBE (L=50)	
13	S34980000	1	フエルト	FELT	
14	S34979000	1	フエルトクミ	FELT ASSY	
15	152948001	2	オイルソフトマド	OIL WINDOW	
16	117150001	2	コードササエカネ	CORD SUPPORT	

118-981-306

N. スプレダー関係 / Spreader mechanism / Spreizvorrichtung / Mécanisme de l'étendeur / Mecanismo extendedor

REF.NO.	CODE	Q'TY	ヒンメイ	NAME OF PARTS	RM
1	S35073001	1	スプレダークドウレバー	SPREADER DRIVING LEVER	
2	S35072101	1	スプレダーレバークミ	SPREADER LEVER ASSY	
2-1	S35071001	1	スプレダーカムレバー	SPREADER CAM LEVER	
2-2	S35070101	1	スプレダーカムコロピン	SPREADER CAM ROLLER PIN	
2-3	S35069001	1	スプレダーカムコロ	SPREADER CAM ROLLER	
3	062400812	2	ナベコ4X8	SCREW, PAN M4X8	
4	025040232	2	ヒラザガネチユウ4	WASHER, PLAIN M 4	
5	S35068001	1	トメネジM3.5	SET SCREW, M3.5	
6	021350106	1	1シユナツト35	NUT, 1 M3.5	
8	S35065001	1	ルーパーリンクササエジク	LOOPER LINK SUPPORT SHAFT	
9	S23612001	1	セットカラークミ	SET SCREW COLLAR ASSY	
10	014060632	2	アナトメ6X6クボミ	SET SCREW, SOCKET (CP) M6X6	

118-981-310

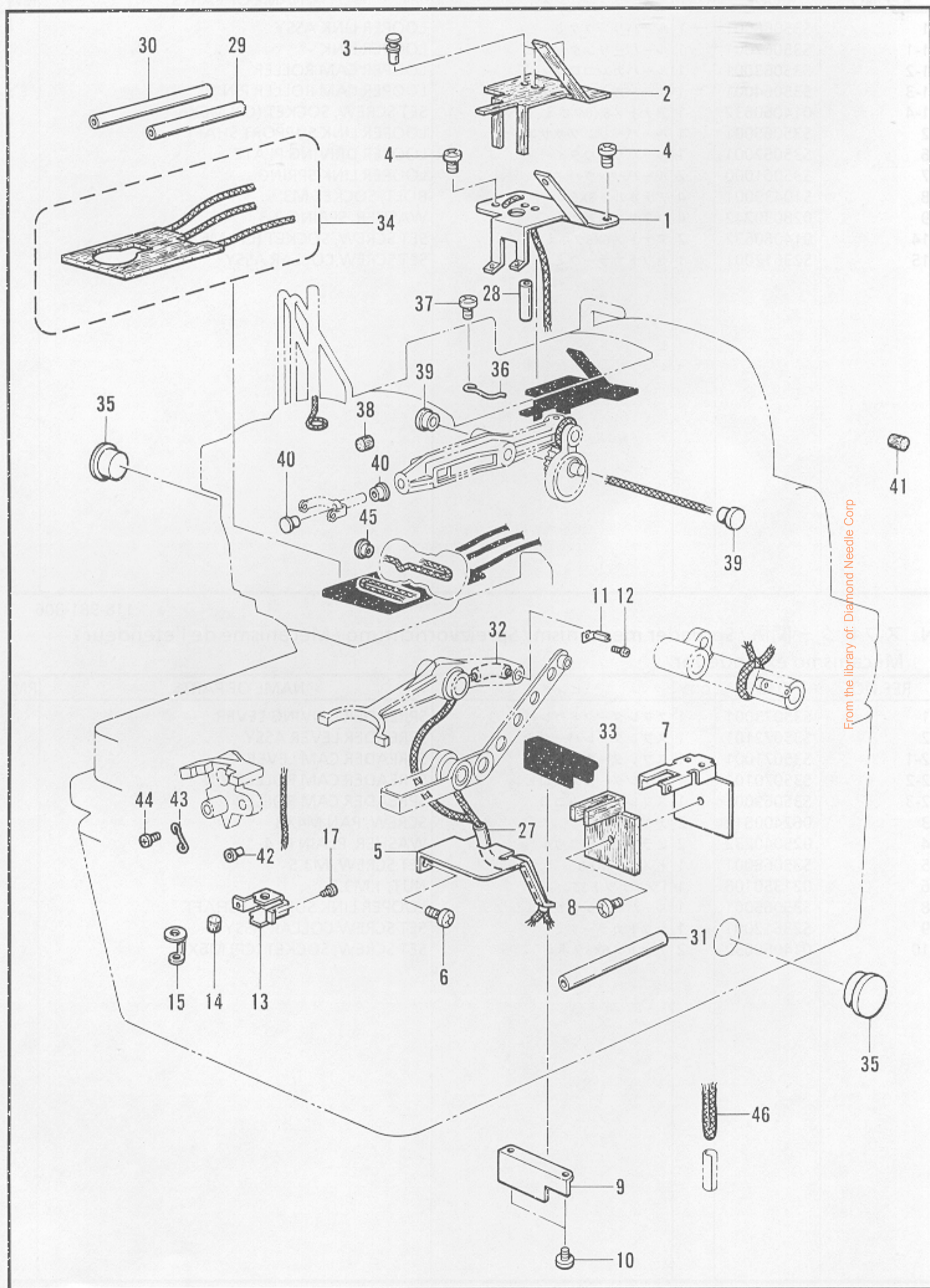

REF.NO.	CODE	Q'TY	ヒンメイ	NAME OF PARTS	RM
1	S35003101	1	トウシンササエL	WICK SUPPORT (L)	
2	S35002000	1	トウシンササエLフェルト	WICK SUPPORT (L) FELT	
3	S35001000	4	ナイロンリベット	NYLON RIVET	
4	062350616	2	ナベコM3.5X6	SCREW, PAN M3.5X6	
5	S35000001	1	ルーバオイルササエ	LOOPER OIL SUPOORT	
6	062400616	1	ナベコM4X6	SCREW, PAN M4X6	
7	S34999001	1	トウシンササエD	WICK SUPOORT (D)	
8	062400616	1	ナベコM4X6	SCREW, PAN M4X6	
9	S34998001	1	シタジクカムカバー	LOWER SHAFT CAM COVER	
10	062400616	2	ナベコM4X6	SCREW, PAN M4X6	
11	S34997001	1	ルーバトウシンオサエ	LOOPER WICK SUPPORT	
12	062300416	1	ナベコM3X4	SCREW, PAN M3X4	
13	S34996001	1	レースフェルトオサエ	FELT SUPPORT	
14	113006001	1	フェルト	FELT	
15	S34995000	1	レースフェルトA	FELT (A)	
17	062300416	1	ナベコM3X4	SCREW, PAN M3X4	
27	S34986000	1	ビニルチューブ	OIL TUBE, L = 135	
28	S34985000	1	ビニルチューブ	OIL TUBE (L = 90)	
29	S34984000	1	ビニルチューブ	OIL TUBE (L = 150)	
30	S34983000	1	ビニルチューブ	OIL TUBE (L = 160)	
31	S34982000	1	ビニルチューブ	OIL TUBE, (L = 70)	
32	S34981000	1	ビニルチューブ	OIL TUBE (L = 50)	
33	S34980000	1	フェルト	FELT	
34	S34979000	1	フェルトクミ	FELT ASSY	
35	152948001	2	オイルボツトマド	OIL WINDOW	
36	117150001	2	コードササエカネ	CORD SUPPORT	
37	062350616	2	ナベコM3.5X6	SCREW, PAN M3.5X6	
38	S34974000	2	ロッドフェルト	ROD FELT	
39	143196001	2	オイルニガシグチ	OIL CAP	
40	143196001	2	オイルニガシグチ	OIL CAP	
41	S34973000	1	ロッドフェルト	ROD FELT	
42	S34972000	1	ビニルチューブ	OIL TUBE	
43	S34971001	1	クミヒモササエ	WICK SUPPORT	
44	060300416	1	バインド3X4	SCREW, BIND M3X4	
45	143196001	1	オイルニガシグチ	OIL CAP	
46	S37173000	1	クミヒモ3X3	WICK 3X3 (L = 50)	
57-2	S37697001	1	ギムプスレッドガイド	GIMP THREAD GUIDE (J)	
58	062400812	1	ナベコM4X8	SCREW, PAN M4X8	
59	S35912001	1	スレッドガイドプレート	THREADING DIAGRAM PLATE	
60	144504001	2	スレッドガイドパイプ	THREAD GUIDE PIPE	
61	154562001	1	プレテンションスプリング	PRE-TENSION SPRING (A)	
62	155510001	1	テンションナット	TENSION NUT	
63	S37745001	1	ギムプスレッドリリースプレート	GIMP THREAD RELEASE PLATE	
64	S37749001	1	ギムプスレッドリリースプレートスプリング	GIMP THREAD RELEASE PLATE SPRING	
65	147236001	1	ナイフセットアームローラー	KNIFE SET ARM ROLLER	
66	025040232	1	ワッシャー、PLAIN M4	WASHER, PLAIN M4	
67	062401212	1	ナベコM4X12	SCREW, PAN M4X12	
68	S37750001	1	ギムプスレッド取り上げガイド	GIMP THREAD TAKE-UP GUIDE (J)	
69	062400812	2	ナベコM4X8	SCREW, PAN M4X8	
70	S20696001	1	スレッドガイドパイプササエ	THREAD GUIDE PIPE SUPPORT	

From the library of: Diamond Needle Corp



Q. 糸通シ関係 / Threading mechanism / Fadenführungsrichtung / Mécanisme de l'enfilage / Mecanismo del enhebrado

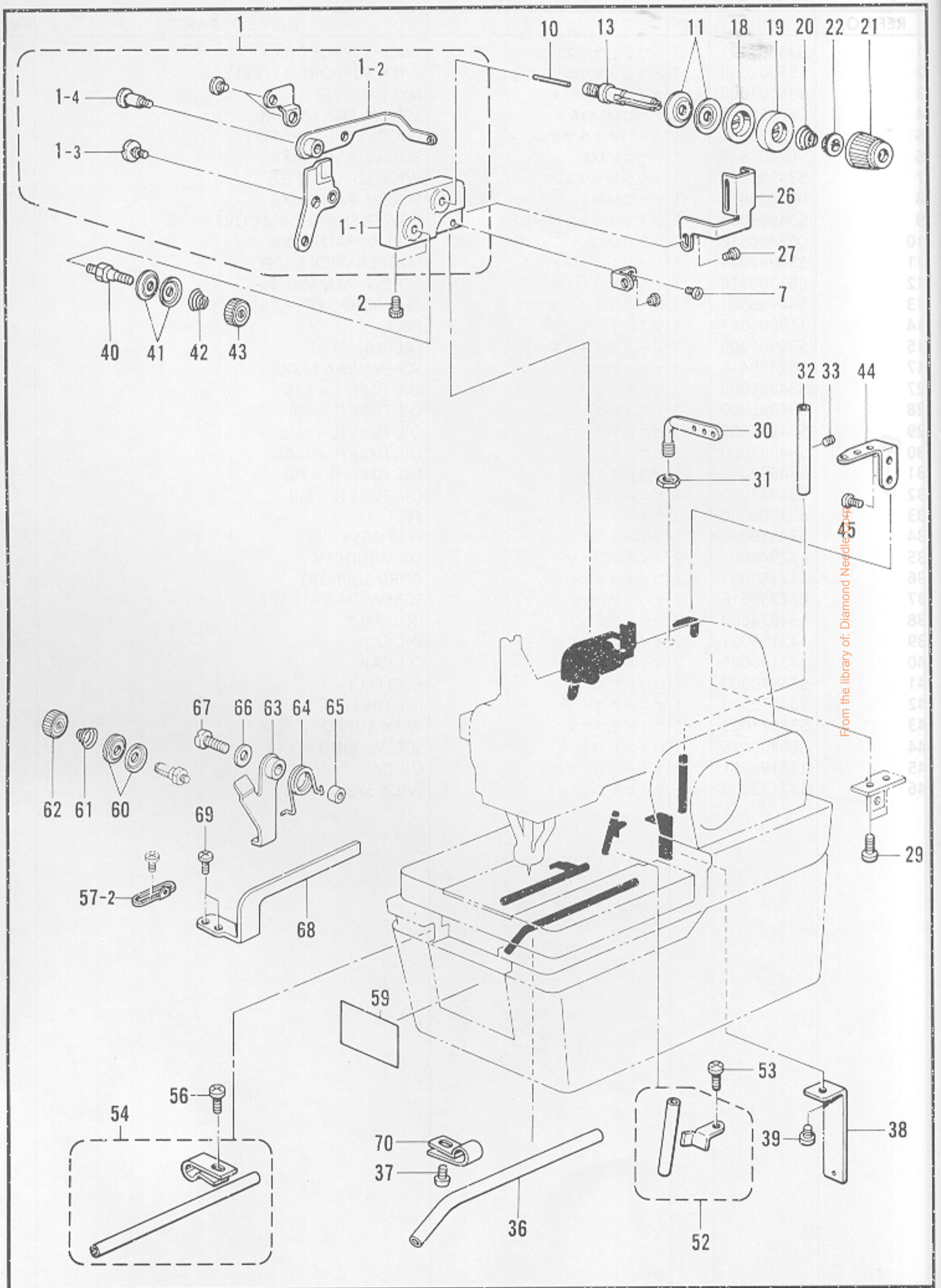

118-981-401

Q. 糸通シ関係 / Threading mechanism / Fadenführungsrichtung /  
Mécanisme de l'enfilage / Mecanismo del enhebrado

REF.NO.	CODE	Q'TY	ヒンメイ	NAME OF PARTS	RM
1	S37874101	1	ウワイトテンションダイクミ	UPPER THREAD TENSION BRACKET ASSY	
1-1	S34917001	1	ウワイトテンションダイ	UPPER THREAD TENSION BRACKET	
1-2	S34918101	1	ウワイトトリレバークミ	UPPER THREAD TAKE-UP LEVER ASSY	
1-3	S34966001	1	ダンネジM4	STUD SCREW, M4	
1-4	S34922101	1	ダンネジM4	STUD SCREW, M4	
2	018401236	2	アナボルト4X12	BOLT, SOCKET M4X12	
7	062350616	1	ナベコM3.5X6	SCREW, PAN M3.5X6	
10	159220101	1	イトユルメピン	PIN	
11	145446001	2	イトチヨウシサラ	TENSION DISC	
13	S34923001	1	ウワイトチヨウシボウ	UPPER THREAD TENSION STUD	
18	159805001	1	イトチヨウシサラオサエ	TENSION DISC PRESSER	
19	144103009	1	イトチヨウシサラオサエ	TENSION DISC PRESSER	
20	159221001	1	イトチヨウシバネ	TENSION SPRING	
21	S20682102	1	イトチヨウシナツト (ミドリ)	TENSION NUT (GREEN)	
22	S20681000	1	チヨウシバネウエザガネ	WASHER	
26	S34924001	1	ウワイトトリレバーアンナイ	UPPER THREAD TAKE-UP LEVER GUIDE	
27	062350616	1	ナベコM3.5X6	SCREW, PAN M3.5X6	
29	062400812	2	ナベコ4X8	SCREW, PAN M4X8	
30	S35466001	1	ミツメイトカケ	THREAD RETAINER	
31	021060306	1	3シユナツト6	NUT, 3 M6	
32	150644009	1	イトアンナイパイプS	THREAD GUIDE PIPE (S)	
33	012400636	1	アナヒラ4X6	SET SCREW, SOCKET (FT) M4X6	
36	S43723001	1	シタイトアンナイパイプA	LOWER THREAD GUIDE PIPE (A)	
37	062400612	2	ナベコM4X6	SCREW, PAN M4X6	
38	S34928001	1	イトアンナイB	THREAD GUIDE (B)	
39	062400612	1	ナベコM4X6	SCREW, PAN M4X6	
40	S20698121	1	イトチヨウシボウ	TENSION STUD	
41	144504001	2	イトアンナイサラ	THREAD GUIDE DISC	
42	154562001	1	プレテンションバネB	PRE-TENSION SPRING (B)	
43	155510001	1	イトチヨウシナツト	TENSION NUT	
44	152889001	1	ミツメイトカケ	THREAD RETAINER	
45	062670616	2	ナベコ357-40X6	SCREW, PAN M3.57-40X6	
52	S34934001	1	シタイトアンナイSクミ	GIMP THREAD GUIDE (S) ASSY	
53	062400812	1	ナベコ4X8	SCREW, PAN M4X8	
54	S43732001	1	シタイトアンナイパイプ	GIMP THREAD GUIDE PIPE	
55	S20696001	1	イトアンナイパイプササエ	THREAD GUIDE PIPE SUPPORT	
56	062400812	2	ナベコ4X8	SCREW, PAN M4X8	
57-2	S37697001	1	シタイトアンナイJ	GIMP THREAD GUIDE (J)	
58	062400812	1	ナベコ4X8	SCREW, PAN M4X8	
59	S35912001	1	イトトオシセツメイバン	THREADING DIAGRAM PLATE	
60	144504001	2	イトアンナイサラ	THREAD GUIDE DISC	
61	154562001	1	プレテンションバネB	PRE-TENSION SPRING (B)	
62	155510001	1	イトチヨウシナツト	TENSION NUT	
63	S37745001	1	シタイトユルメイタ	GIMP THREAD RELEASE PLATE	
64	S37749001	1	シタイトユルメイタバネ	GIMP THREAD RELEASE PLATE SPRING	
65	147236001	1	メストリツケウデコロ	KNIFE SET ARM ROLLER	
66	025040232	1	ヒラザガネチユウ4	WASHER, PLAIN M 4	
67	062401212	1	ナベコ4X12	SCREW, PAN M4X12	
68	S37750001	1	シタイトリアンナイJ	GIMP THREAD TAKE-UP GUIDE (J)	
69	062400812	2	ナベコ4X8	SCREW, PAN M4X8	
70	S20696001	1	イトアンナイパイプササエ	THREAD GUIDE PIPE SUPPORT	

From the library of: Diamond Needle Corp

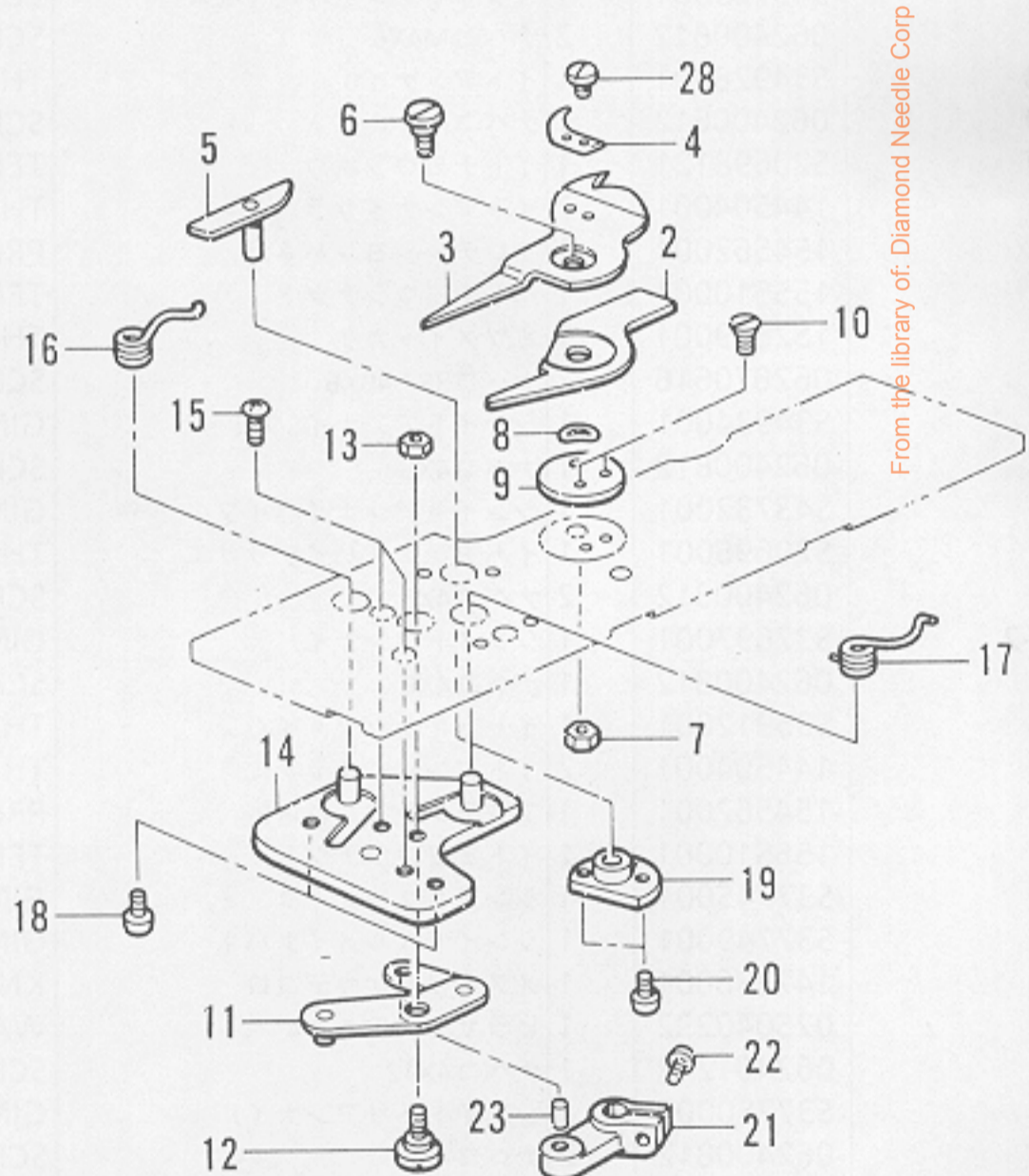
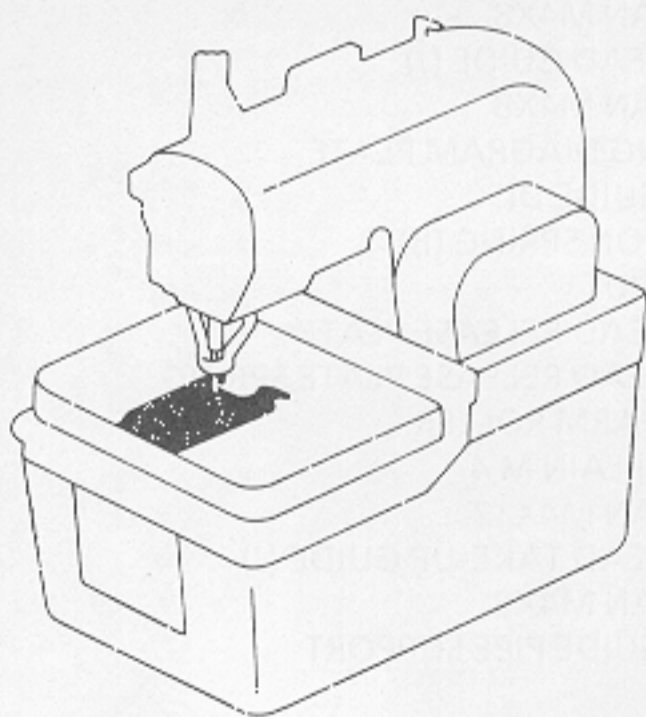
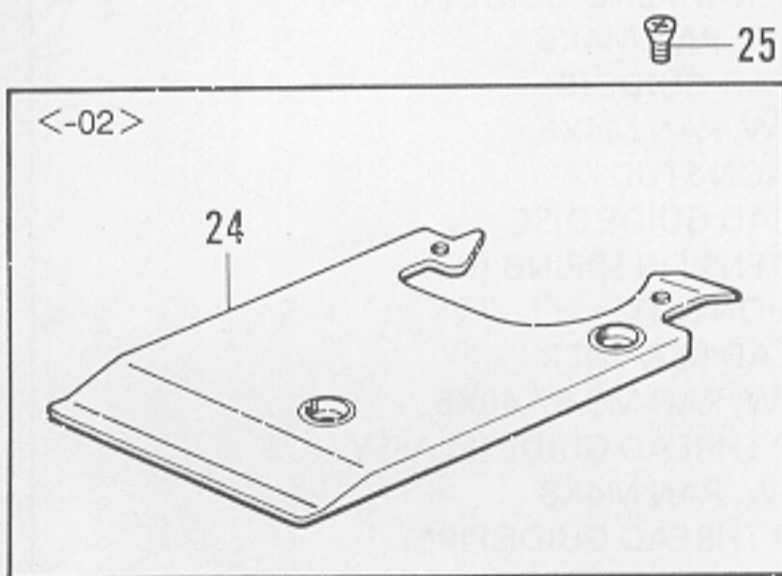
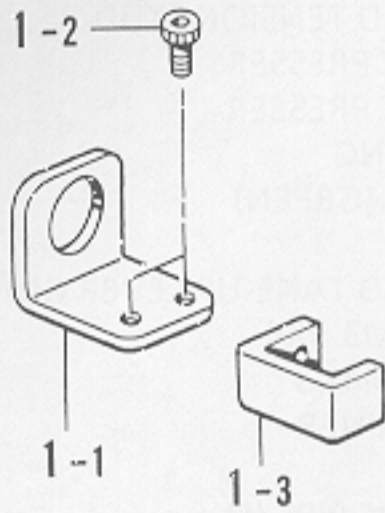

R. 糸切り関係 / Thread trimmer mechanism / Fadenabschneidevorrichtung /  
Mécanisme de coupe-fil / Mecanismo de la cortadura de hiros

REF.NO.	CODE	Q'TY	ヒンメイ	NAME OF PARTS	RM
<-02, -52 L1>					
2	S37673101	1	イドウハL1R	MOVABLE KNIFE (L1)(R)	
3	S37669101	1	イドウハL1L	MOVABLE KNIFE (L1)(L)	
4	S37665000	1	イトサバキL1	THREAD HANDLER L1	
5	S37661001	1	イドウハクドウカムL1	MOVABLE KNIFE DRIVING CAM (L1)	
<-02, -52 L2, L5>					
2	S37674101	1	イドウハL2R	MOVABLE KNIFE (L2)(R)	
3	S37670101	1	イドウハL2L	MOVABLE KNIFE (L2)(L)	
4	S37666000	1	イトサバキL2	THREAD HANDLER L2	
5	S37662001	1	イドウハクドウカムL2	MOVABLE KNIFE DRIVING CAM (L2)	
<-02, -52 L3, L6>					
2	S37675101	1	イドウハL3R	MOVABLE KNIFE (L3)(R)	
3	S37671101	1	イドウハL3L	MOVABLE KNIFE (L3)(L)	
4	S37667000	1	イトサバキL3	THREAD HANDLER L3	
5	S37663001	1	イドウハクドウカムL3	MOVABLE KNIFE DRIVING CAM (L3)	
<-02, -52 L4, L7>					
2	S37676101	1	イドウハL4R	MOVABLE KNIFE (L4)(R)	
3	S37672101	1	イドウハL4L	MOVABLE KNIFE (L4)(L)	
4	S37668000	1	イトサバキL4	THREAD HANDLER L4	
5	S37664001	1	イドウハクドウカムL4	MOVABLE KNIFE DRIVING CAM (L4)	
1-1	S34914001	1	イトキリシリンダササエイタ	THREAD TRIMMER CYLINDER SUPPORT PLATE	
1-2	018400832	2	アナボルト4X8	BOLT, SOCKET M4X8	
1-3	S34913001	1	イトキリシリンダツメ	THREAD TRIMMER CYLINDER CLAW	
6	S37660101	1	ダンネジM4	SHOULDER SCREW, M4	
7	021400202	1	2シユナツト4	NUT, 2 M4	
8	S37654000	1	ナミザガネ	WASHER, WAVE	
9	S37655101	1	メスササエザガネ	KNIFE SUPPORT WASHER	
10	141542001	2	サラネジ3.18	SCREW, FLAT M3.18	
11	S37656001	1	イトキリリンクレバーJクミ	THREAD TRIMMER LINK LEVER (J) ASSY	
12	S34881001	1	ダンネジM4	SHOULDER SCREW, M4	
13	021400202	1	2シユナツト4	NUT, 2 M4	
14	S37820001	1	リンクシテンプレートクミ	LINK FURCRUM PLATE ASSY	
15	062400616	2	ナベコM4X6	SCREW, PAN M4X6	
16	S37652001	1	モドシバネL	SPRING (L)	
17	S37653001	1	モドシバネR	SPRING (R)	
18	062300416	2	ナベコM3X4	SCREW, PAN M3X4	
19	S34906000	1	イトキリウデメタル	THREAD TRIMMER ARM BUSH	
20	062250612	2	ナベコ2.6X6	SCREW, PAN M2.6X6	
21	S37659001	1	イトキリレバーウデB	THREAD CUTTER LEVER ARM (B)	
22	S21716001	1	ボタンヘッドネジ4X10	SCREW, BUTTON HEAD M4X10	
23	S37858000	1	ニードルピン4X8	NEEDLE PIN 4X8	
25	004401003	2	+サラネジ4X10	SCREW, FLAT M4X10	
28	153787001	2	シメネジ2.38	SCREW, M2.38	
<-02>					
24	S37700001	1	オサエプレートU	PRESSER PLATE (U)	

From the library of: Diamond Needle Corp

S. 上糸切り関係 / Upper thread trimmer mechanism / Oberer Fadenabschneider / Mécanisme de la coupe-fil supérieur / Mecanismo de la recortadora de orillos superior

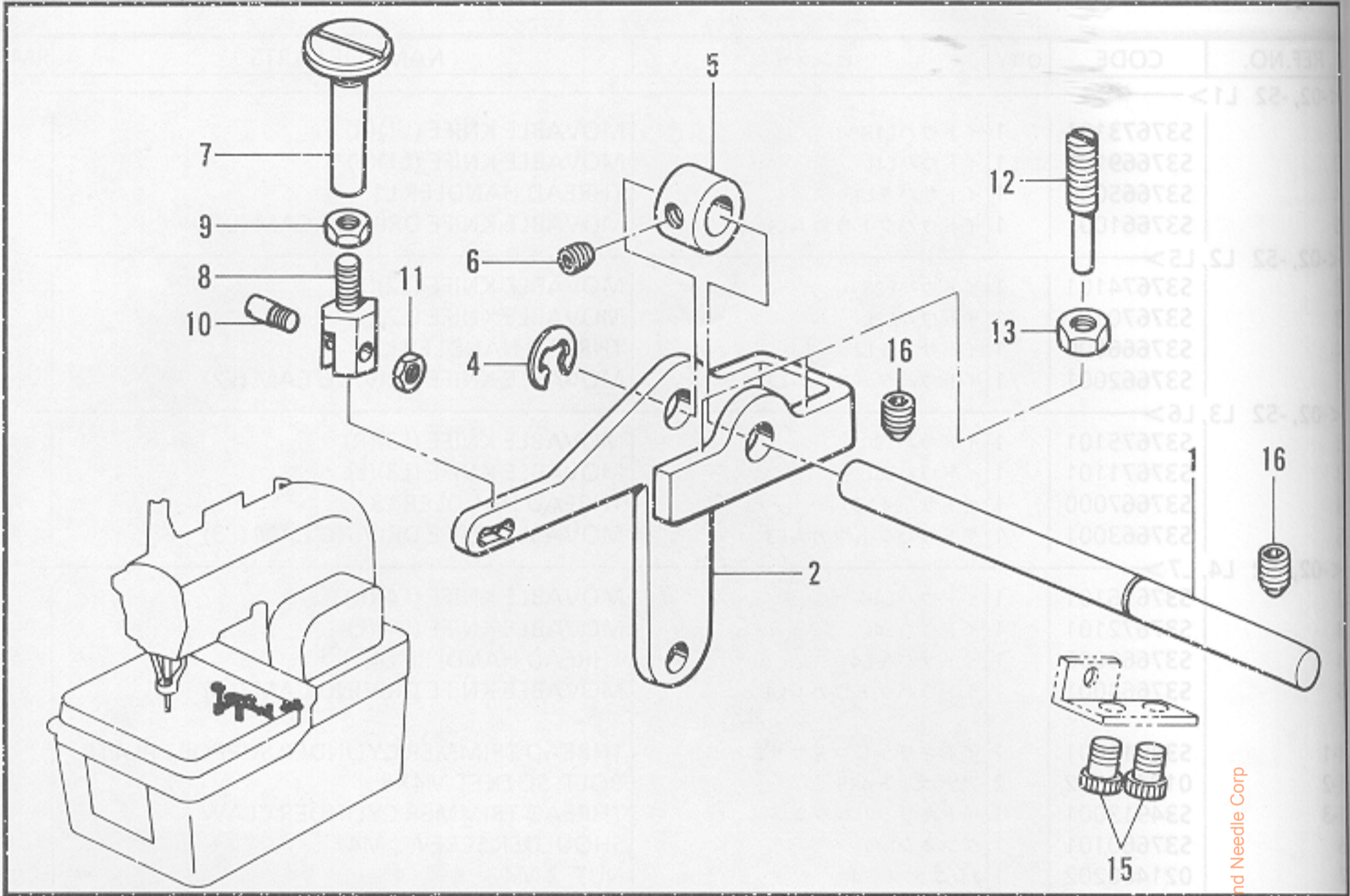

118-981-409

T. 針位置検出器関係 / Synchronizer / Synchronisator / Synchronisateur / Sincronizador

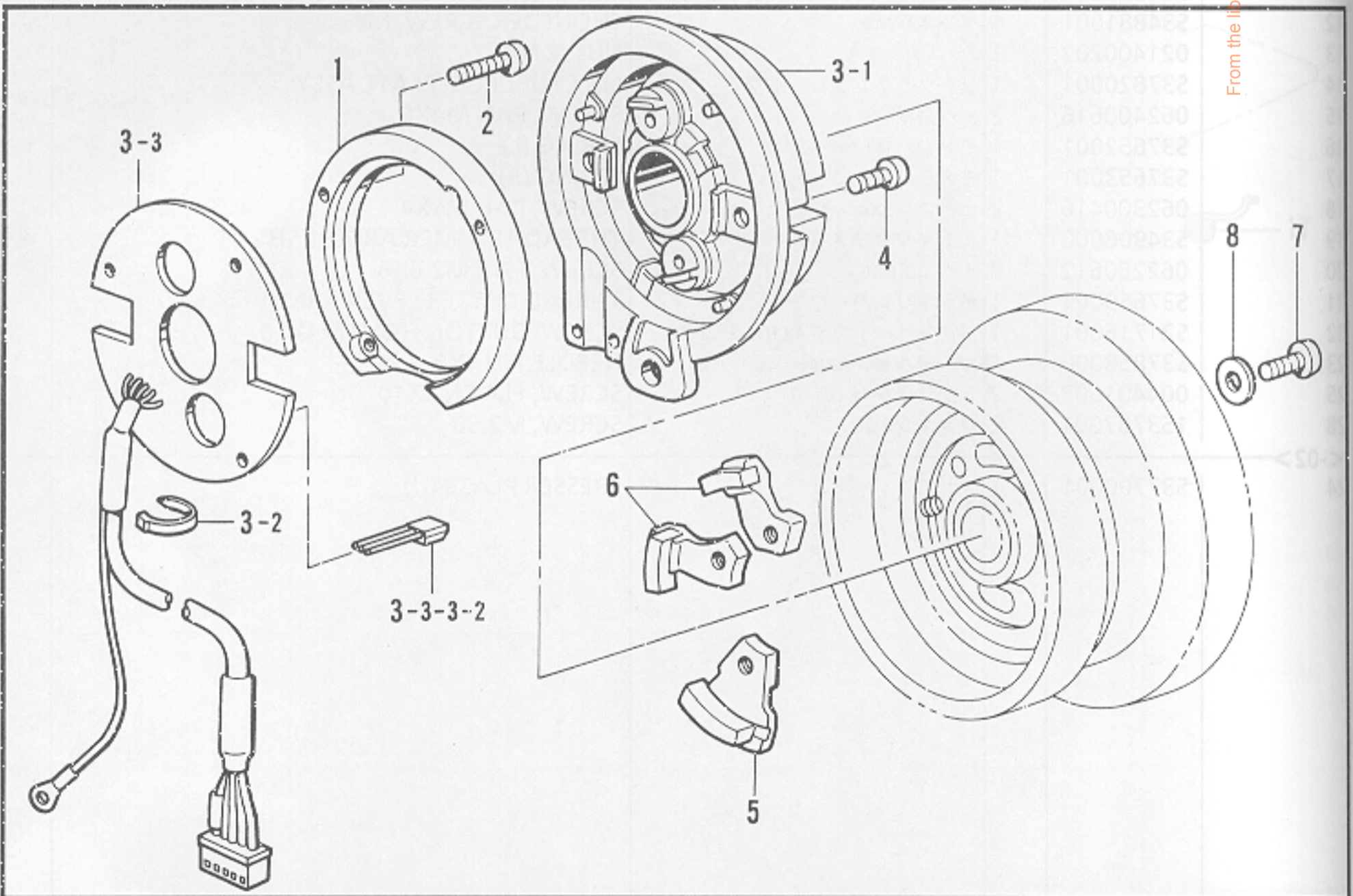

118-981-501

S. 上糸

de

REF.
1
2
4
5
6
7
8
9
10
11
12
13
15
16

T. 金

RE

REF.
1
2
3
3-1
3-2
3-3
3-3-2
4
5
6
7
8

S. 上糸切り関係 / Upper thread trimmer mechanism / Oberer Fadenabschneider / Mécanisme de la coupe-fil supérieur / Mecanismo de la recortadora de orillos superior

REF.NO.	CODE	Q'TY	ヒンメイ	NAME OF PARTS	RM
1	S35058001	1	イトキリレバーシク	THREAD TRIMMER LEVER SHAFT	
2	S35059001	1	イトキリレバー	THREAD TRIMMER LEVER	
4	048050342	1	トメワE5	RETAINING RING, E5	
5	S35060001	1	セットカラー	SET SCREW COLLAR	
6	014400432	1	アナクボミ4X4	SET SCREW, SOCKET (CP) M4X4	
7	S35361001	1	イトキリレバーハンマ	THREAD TRIMMER LEVER HAMMER	
8	S35362001	1	イトキリチヨウセツネジ	THREAD TRIMMER ADJUST SCREW	
9	021350106	1	1シユナツト35	NUT, 1 M3.5	
10	S35235001	1	クランプササエピン	CLAMP SUPPORT PIN	
11	021300302	1	3シユナツト3	NUT, 3 M3	
12	S35364001	2	トメネジ4X26	SET SCREW, M4X26	
13	021400202	2	2シユナツト4	NUT, 2 M4	
15	018401032	2	アナボルト4X10	BOLT, SOCKET M4X10	
16	014060632	2	アナトメ6X6クボミ	SET SCREW, SOCKET (CP) M6X6	

118-981-409

T. 針位置検出器関係 / Synchronizer / Synchronisator / Synchronisateur / Sincronizador

REF.NO.	CODE	Q'TY	ヒンメイ	NAME OF PARTS	RM
1	S43707001	1	NPササエダイB	NP SUPPORT BRACKET (B)	
2	062401016	2	ナベコ4X10	SCREW, PAN M4X10	
3	S43351001	1	シンクロナイザクミB	SYNCHRONIZER ASSY (B)	
3-1	S38073000	1	シンクロナイザケース	SYNCHRONIZER CASE	
3-2	228475000	1	ケツソクバンド1.9X80	FASTENING BAND, 1.9X80	
3-3	S43352001	1	シンクロキバンクミB	SYNCHRO-PCB ASSY	
3-3-3-2	J00686001	1	ホールICDN6848	HOLE ICDN6848	
4	062400612	2	ナベコM4X6	SCREW, PAN M4X6	
5	S38080001	1	ハリシタジシャククミ	NEEDLE DOWN MAGNET ASSY	
6	S43747001	2	ハリシタジシャククミS	NEEDLE DOWN MAGNET ASSY (S)	
7	062681412	3	ナベコ437-40X14	SCREW, PAN SM4.37-40X14	
8	025680132	3	ヒラザガネシヨウ4.37	WASHER, PLAIN S 4.37	

From the library of: Diamond Needle Corp

118-981-501

U1. コントロールボックス関係 / Control box mechanism / Schaltkasten / Mécanisme du boîtier de contrôle / Mecanismo de la caja de controles

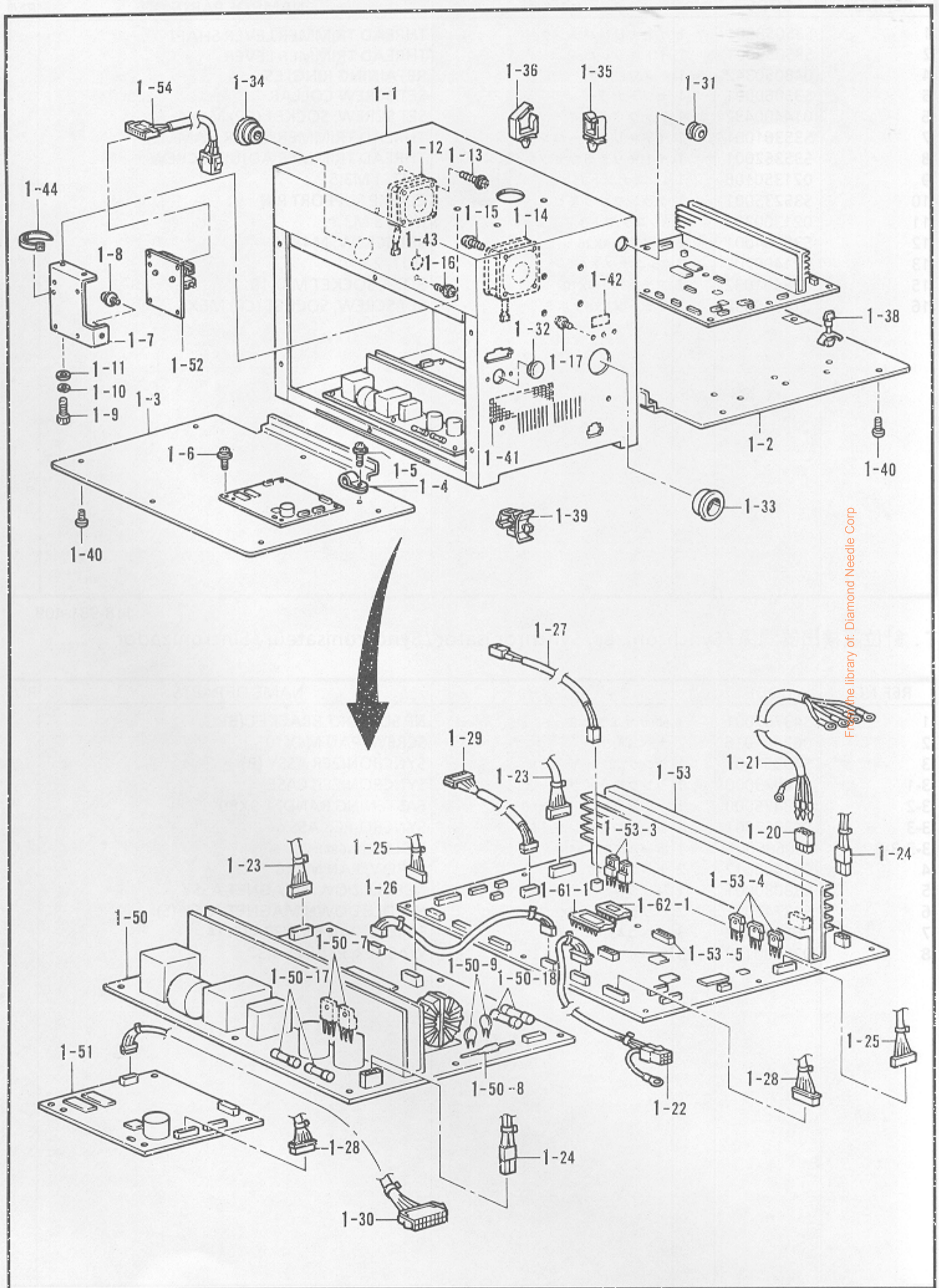

From the library of: Diamond Needle Corp

U1. コントロールボックス関係 / Control box mechanism / Schaltkasten / Mécanisme du boîtier de contrôle / Mecanismo de la caja de controles

REF.NO.	CODE	Q'TY	ヒンメイ	NAME OF PARTS	RM
1	S43299009	1	981ボックスクミ	981 BOX ASSY	
1-1	S43300009	1	981デンゲンボックス	POWER SUPPLY BOX ASSY, 981	
1-2	S43171009	1	キバントリツケイタ	PCB SETTING PLATE	
1-3	S43301009	1	981パネルフタクミ	PANEL CAP ASSY, 981	
1-4	149287000	1	ナイロンクランプ	CORD HOLDER, 7N	
1-5	0A5300805	1	+ナベザクミ3X8DB	SCREW, PAN (S/P WASHER) M3X8	
1-6	0A4300605	4	+ナベザクミ3X6DA	SCREW, PAN (S/P WASHER) M3X6	
1-7	S43356001	1	Rキバンササエイタ	R CIRCUIT BOARD BASE PLATE	
1-8	0A5400806	1	+ナベザクミ4X8DB	SCREW, PAN (S/P WASHER) M4X8	
1-9	018061022	2	アナボルト6X10	BOLT, SOCKET M6X10	
1-10	028060246	2	バネザガネ2-6	WASHER, SPRING 2-6	
1-11	025060232	2	ヒラザガネチユウ6	WASHER, PLAIN M 6	
1-12	S38094100	1	DCファンモータクミ	DC FAN MOTOR ASSY	
1-13	0A5403006	2	+ナベザクミ4X30DB	SCREW, PAN (S/P WASHER) M4X30	
1-14	S43355000	1	DCファンモータ80クミ	DC FAN MOTOR ASSY	
1-15	0A5403006	4	+ナベザクミ4X30DB	SCREW, PAN (S/P WASHER) M4X30	
1-16	0A5400806	1	+ナベザクミ4X8DB	SCREW, PAN (S/P WASHER) M4X8	
1-17	0A5401006	3	ナベコバネヒラ4X10	SCREW, PAN (S/P WASHER) M4X10	
1-20	S16568000	1	コネクタ3191-03R1	CONNECTOR, 3191-03R1	
1-21	S43350000	1	モータコード	MOTOR CORD	
1-22	S42260000	1	フットSWコード434クミ	FOOT SWITCH HARNESS ASSY, 434	
1-23	S38107100	1	セイギヨデンゲンコード	CONTROL POWER SUPPLY HARNESS	
1-24	S38108000	1	モータデンゲンコード	MOTOR POWER SUPPLY HARNESS	
1-25	S38109100	1	ゲートデンゲンコード	GATE POWER SUPPLY HARNESS	
1-26	S38110000	1	PERコード	PER HARNESS	
1-27	S43304000	1	DC55コード	DC55 CORD	
1-28	S43305000	1	パネルコード	PANEL CORD	
1-29	S43306000	1	RPMDコード	RPMD CORD	
1-30	S43307000	1	TYPEコード	TYPE CORD	
1-31	S11949000	1	ゴムブツシュ	RUBBER BUSH	
1-32	150592009	1	ゴムセン16	RUBBER CAP, 16	
1-33	S43274000	1	ブツシュTB-2938	BUSH, TB-2938	
1-34	S43308000	1	ブツシュTB-2533	BUSH, TB-2533	
1-35	S43275000	10	コードクランプWS2NS	CORD CLAMP, WS2NS	
1-36	S43318000	5	クランプLWS8S2.5W	CLAMP LWS8S2.5W	
1-38	S00554000	22	サポート6NS	SUPPORT, 6NS	
1-39	S31760000	2	CKSクランプ26L	CORD CLAMP, 26L	
1-40	008400604	12	+トラスコ4X6	SCREW, TRUSS M4X6	
1-41	S43309000	1	ボウジンアミ	FRAGMENT PROTECTOR NET	
1-42	S37059001	1	PEマーク	LABEL, PE	
1-43	S37060001	1	アースマーク	LABEL, GROUNDING	
1-44	228475000	2	ケツソクバンド1.9X80	FASTENING BAND, 1.9X80	
1-50	S43173001	1	デンゲンキバンクミ	POWER SUPPLY PCB ASSY	
1-50-7	S38200000	2	MOSFET2SK1938	MOS FET, 2SK1938	
1-50-8	232384001	1	SアブソバD5A362MA	SURGE ABSORBER	
1-50-9	S38201000	2	バリスタV14D471	VARISTOR	
1-50-17	S08030000	2	Gヒューズ5AFB	FUSE, 5A FB	
1-50-18	153242000	2	ヒューズ6A	FUSE, 6A	
1-51	S43313001	1	パネルキバンクミ	PANEL CIRCUIT BOARD ASSY	
1-52	S43316001	1	PMDキバンクミ	PMD CIRCUIT BOARD ASSY	
1-53	S43210001	1	セイギヨキバンクミ	CONTROL PCB ASSY	
1-53-1	U38337000	10	FET2SJ350	TRANSISTOR, FET:2SJ350	
1-53-2	U38338000	10	FET2SK2202	TRANSISTOR, FET:2SK2202	
1-53-3	S38155000	4	MOSFET2SK1306	MOS FET, 2SK1306	
1-53-4	S38164000	6	MOSFET2SK1937	MOSFET2SK1937	
1-53-5	U32744000	2	DIPSWDSS708	DIP SWITCH:DSS708	
1-61	S43310000	1	PROM981セイギヨクミ	PROM 981 CONTROL ASSY	
1-61-1	U85274000	1	LSIM5M27C101K15	LSI:M5M27C101K15	
1-62	S43311000	1	PROM981モータクミ	PROM 981 MOTOR ASSY	
1-62-1	S38143000	1	CM0SLSI27C512	CMOS LSI, 27C512	

From the library of: Diamond Needle Corp



U2. コントロールボックス関係 / Control box mechanism / Schaltkasten / Mécanisme du boîtier de contrôle / Mecanismo de la caja de controles

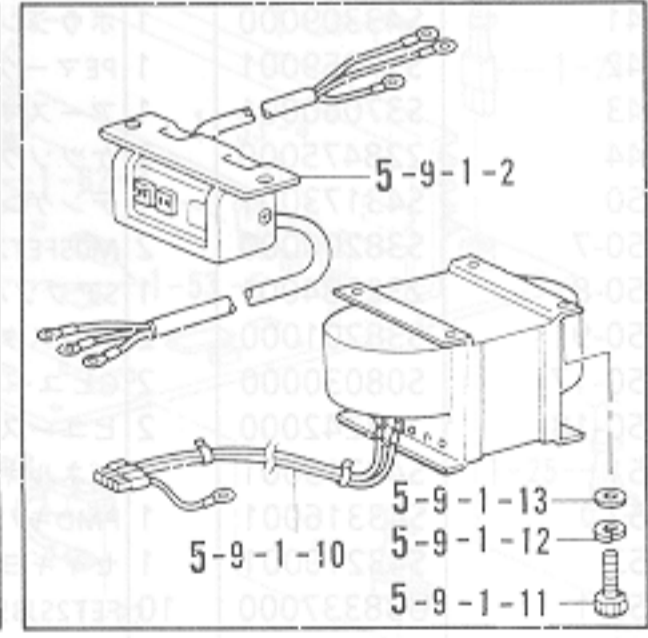
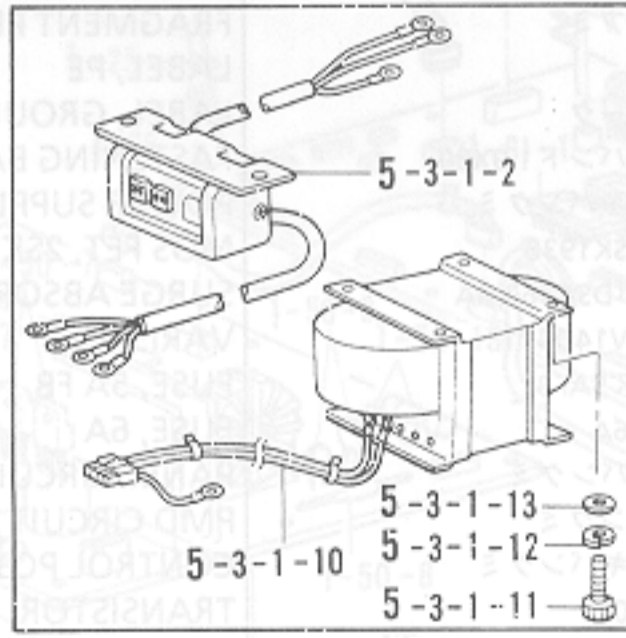
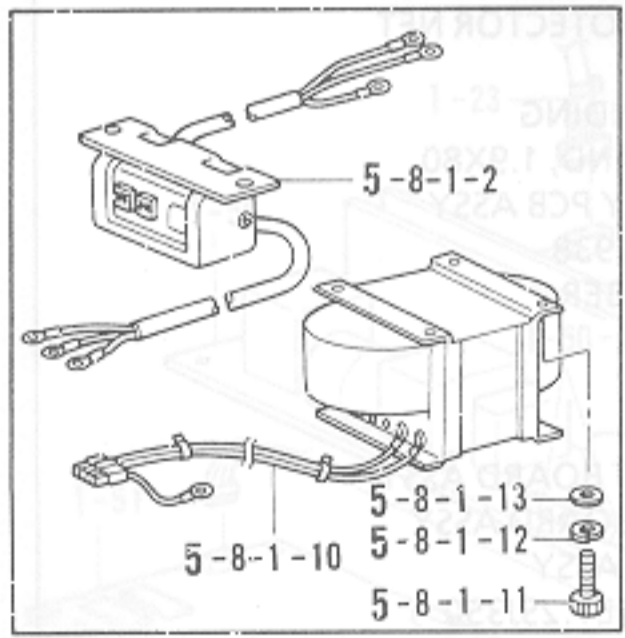
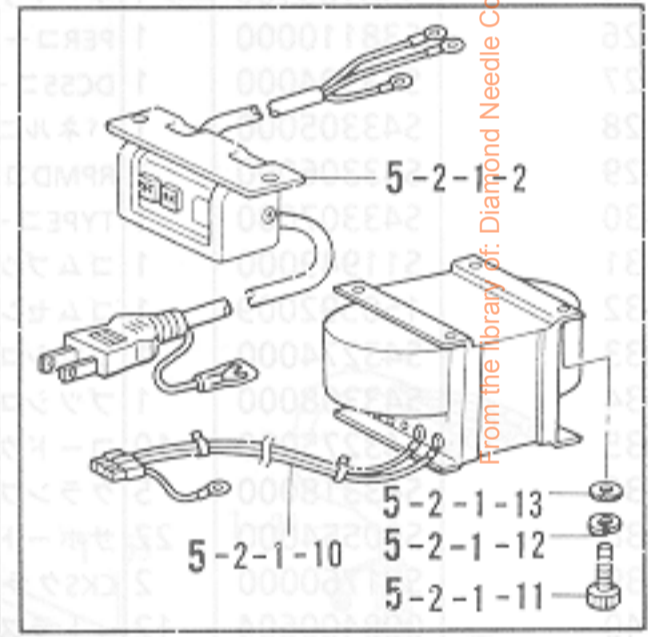
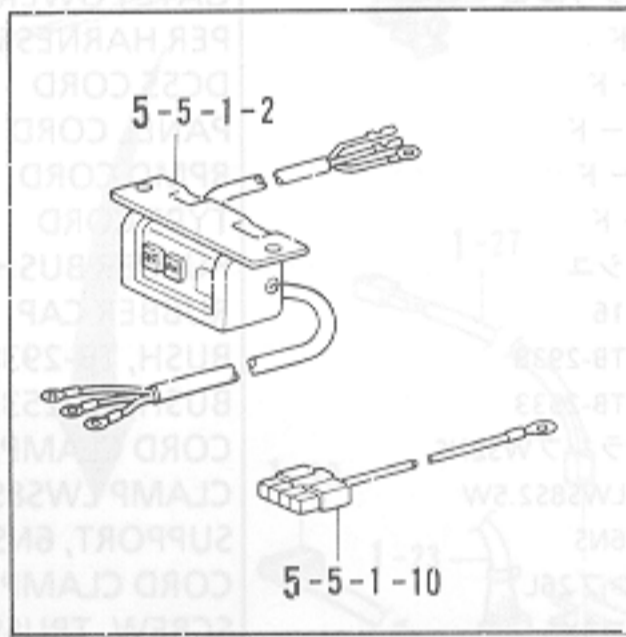
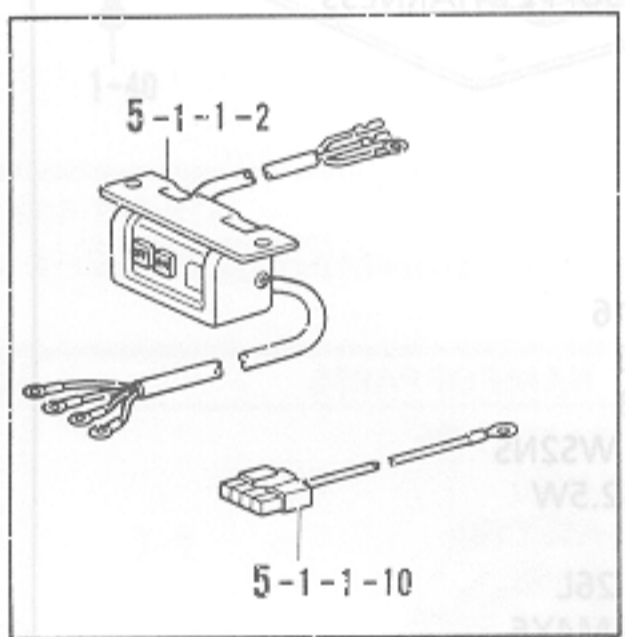
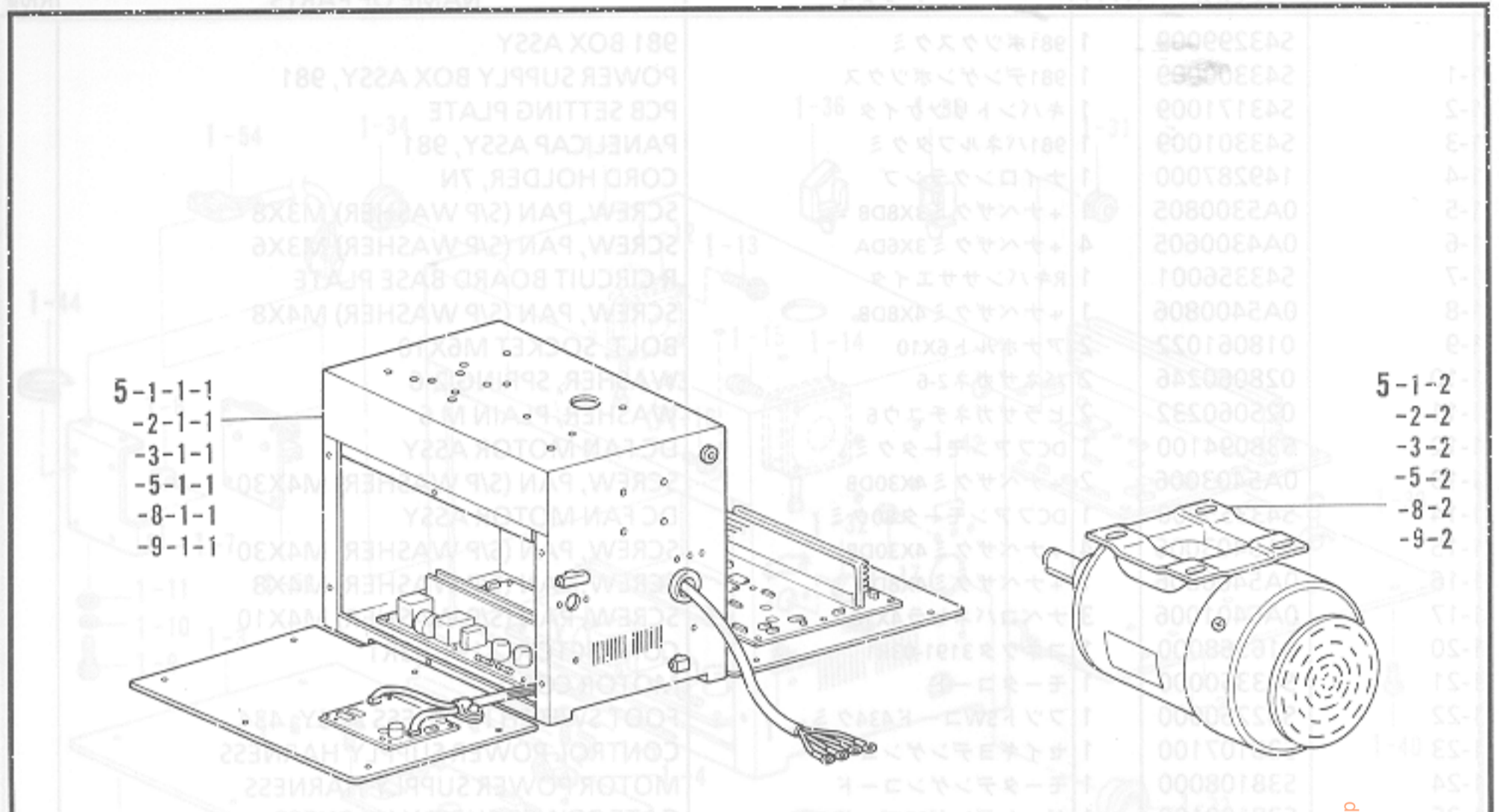

From the library of: Diamond Needle Corp

U2. コントロールボックス関係 / Control box mechanism / Schaltkasten / Mécanisme du boîtier de contrôle / Mecanismo de la caja de controles

REF.NO.	CODE	QTY	ヒンメイ	NAME OF PARTS	RM
<981ボックスソウクミA1ヨウ/FOR POWER SUPPLY BOX ASSY, 981(A1)>					
<サンソウ200V,220V/THREE-PHASE 200V,220V>					
5-1	S44290009	1	モータユニットコンボウA1	MOTOR UNIT (A1)	
5-1-1	S43291009	1	981ボックスソウクミA1	POWER SUPPLY BOX ASSY, 981(A1)	
5-1-1-1	S43299009	1	981ボックスクミ	BOX ASSY, 981	
5-1-1-2	S38112001	1	デンゲンSWクミA	POWER SUPPLY SWITCH ASSY, A	
5-1-1-10	S38123000	1	ACINコネクタクミ	AC IN CONNECTOR ASSY	
5-1-2	S44758000	1	ゼンハイ3ソウモータ	TOTALLY ENCLOSED 3-PHASE MOTOR	
<981ボックスソウクミB1ヨウ/FOR POWER SUPPLY BOX ASSY, 981(B1)>					
<タンソウ100V/SINGLE-PHASE 100V>					
5-2	S44292009	1	モータユニットコンボウB1	MOTOR UNIT (B1)	
5-2-1	S43292009	1	981ボックスソウクミB1	POWER SUPPLY BOX ASSY, 981(B1)	
5-2-1-1	S43299009	1	981ボックスクミ	BOX ASSY, 981	
5-2-1-2	S38114000	1	デンゲンSWクミB	POWER SUPPLY SWITCH ASSY, B	
5-2-1-10	S38124000	1	ヘンカントランスBクミ	CONVERSION TRANSFORMER ASSY, B	
5-2-1-11	018061022	4	アナボルト6X10	BOLT, SOCKET M6X10	
5-2-1-12	028060246	4	バネザガネ2-6	WASHER, SPRING 2-6	
5-2-1-13	025060232	4	ヒラザガネチユウ6	WASHER, PLAIN M 6	
5-2-2	S44758000	1	ゼンハイ3ソウモータ	TOTALLY ENCLOSED 3-PHASE MOTOR	
<981ボックスソウクミC1ヨウ/FOR POWER SUPPLY BOX ASSY, 981(C1)>					
<サンソウ415V/THREE-PHASE 415V>					
5-3	S44294009	1	モータユニットコンボウC1	MOTOR UNIT (C1)	
5-3-1	S43293009	1	981ボックスソウクミC1	POWER SUPPLY BOX ASSY, 981(C1)	
5-3-1-1	S43299009	1	981ボックスクミ	BOX ASSY, 981	
5-3-1-2	S38117000	1	デンゲンSWクミC	POWER SUPPLY SWITCH ASSY, C	
5-3-1-10	S38127000	1	ヘンカントランスCクミ	CONVERSION TRANSFORMER ASSY, C	
5-3-1-11	018061022	4	アナボルト6X10	BOLT, SOCKET M6X10	
5-3-1-12	028060246	4	バネザガネ2-6	WASHER, SPRING 2-6	
5-3-1-13	025060232	4	ヒラザガネチユウ6	WASHER, PLAIN M 6	
5-3-2	S44758000	1	ゼンハイ3ソウモータ	TOTALLY ENCLOSED 3-PHASE MOTOR	
<981ボックスソウクミC2ヨウ/FOR POWER SUPPLY BOX ASSY, 981(C2)>					
<サンソウ380V/THREE-PHASE 380V>					
5-3	S44295009	1	モータユニットコンボウC2	MOTOR UNIT (C2)	
5-3-1	S43294009	1	981ボックスソウクミC2	POWER SUPPLY BOX ASSY, 981(C2)	
5-3-1-1	S43299009	1	981ボックスクミ	BOX ASSY, 981	
5-3-1-2	S38117000	1	デンゲンSWクミC	POWER SUPPLY SWITCH ASSY, C	
5-3-1-10	S38127000	1	ヘンカントランスCクミ	CONVERSION TRANSFORMER ASSY, C	
5-3-1-11	018061022	4	アナボルト6X10	BOLT, SOCKET M6X10	
5-3-1-12	028060246	4	バネザガネ2-6	WASHER, SPRING 2-6	
5-3-1-13	025060232	4	ヒラザガネチユウ6	WASHER, PLAIN M 6	
5-3-2	S44758000	1	ゼンハイ3ソウモータ	TOTALLY ENCLOSED 3-PHASE MOTOR	
<981ボックスソウクミA2ヨウ/FOR POWER SUPPLY BOX ASSY, 981(A2)>					
<タンソウ220V/SINGLE-PHASE 220V>					
5-5	S44291009	1	モータユニットコンボウA2	MOTOR UNIT (A2)	
5-5-1	S43295009	1	981ボックスソウクミA2	POWER SUPPLY BOX ASSY, 981(A2)	
5-5-1-1	S43299009	1	981ボックスクミ	BOX ASSY, 981	
5-5-1-2	S38112002	1	デンゲンSWクミA	POWER SUPPLY SWITCH ASSY, A	
5-5-1-10	S38123000	1	ACINコネクタクミ	AC IN CONNECTOR ASSY	
5-5-2	S44758000	1	ゼンハイ3ソウモータ	TOTALLY ENCLOSED 3-PHASE MOTOR	

From the library of: Diamond Needle Corp.

U2. コントロールボックス関係 / Control box mechanism / Schaltkasten / Mécanisme du boîtier de contrôle / Mecanismo de la caja de controles

U2.

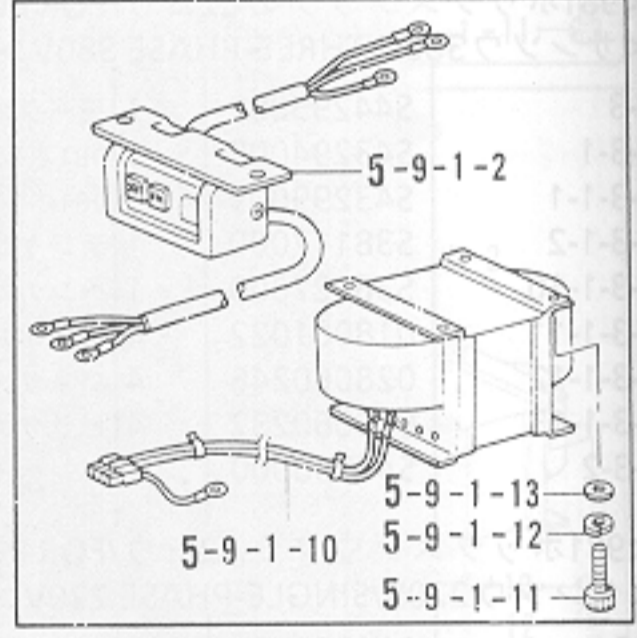
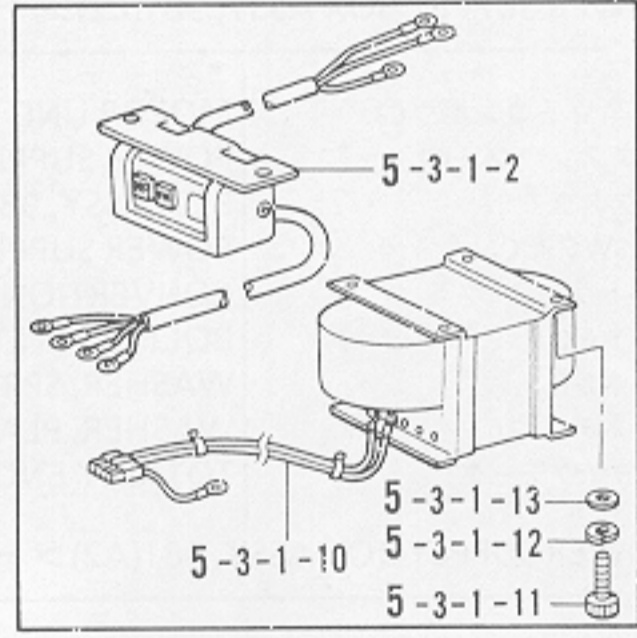
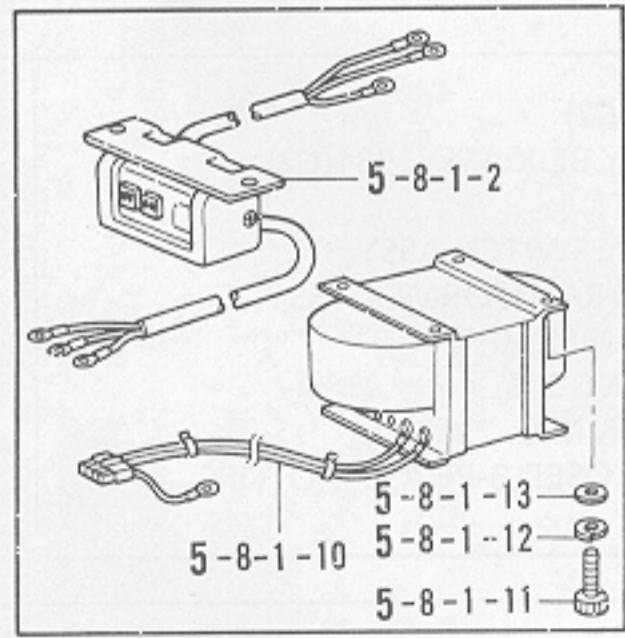
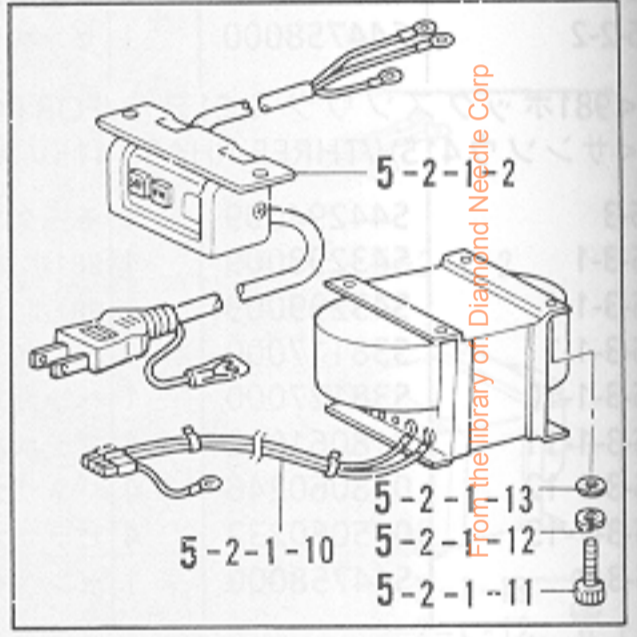
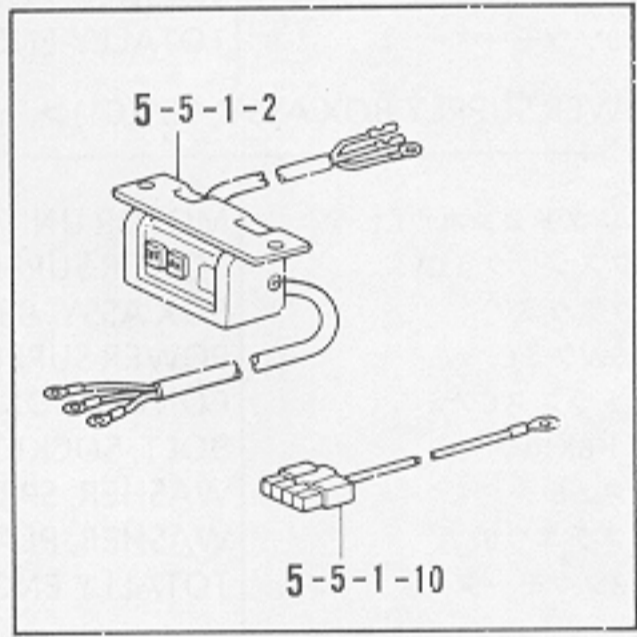
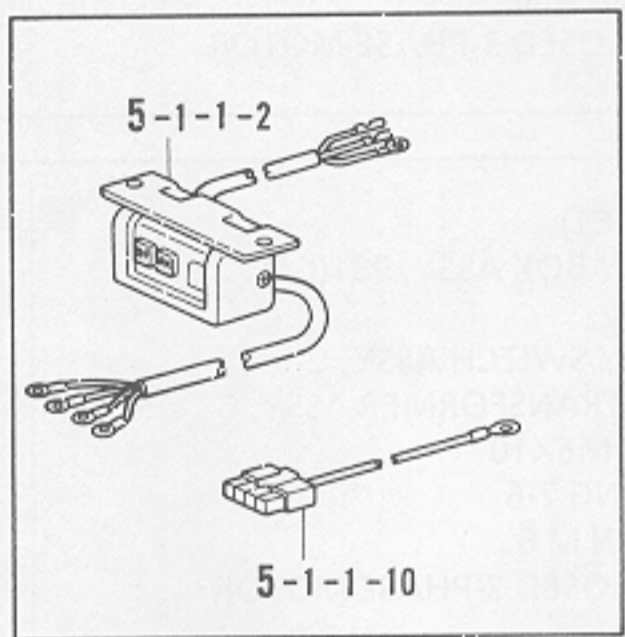
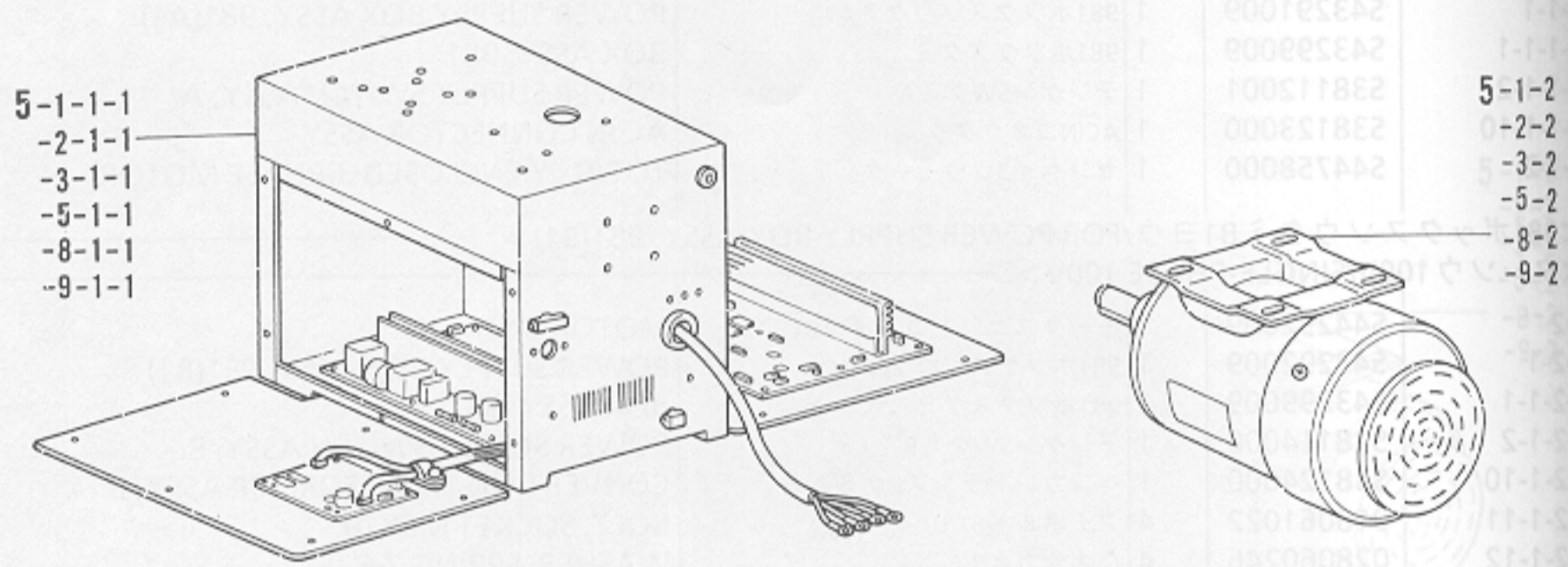

From the library of Diamond Needle Corp

**ARTS Import Error:**

**Application error: File**

**'E:\www\images\PartsBook\brother\Dh4-b981\0044.gif' doesn't appear to be a GIF file**

V. 空圧関係 / Air pressure mechanism / Luftdruck / Mécanisme de la pression d'air / Mecanismo de la presión de aire

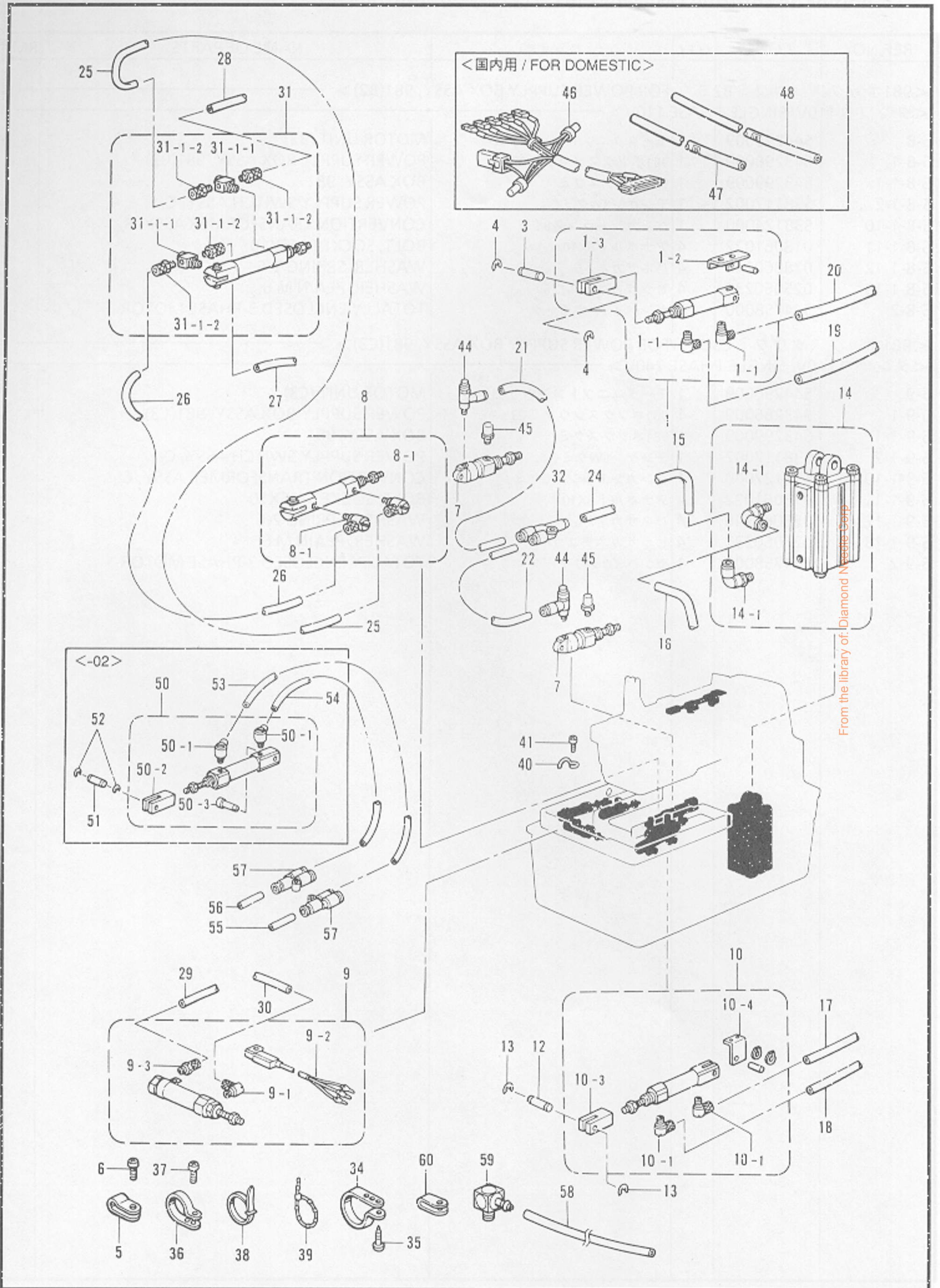

V. 空圧関係 / Air pressure mechanism / Luftdruck /  
Mécanisme de la pression d'air / Mecanismo de la presión de aire

REF.NO.	CODE	Q'TY	品名	NAME OF PARTS	RM
1	S35349101	1	シリンダ10X15クミ	CYLINDER 10X15 ASSY	
1-1	S12150000	2	ホースエルボM-5HL-4	TUBE ELBOW (M-5HL-4)	
1-2	S34925101	1	イトユルメシリンダササエ	THREAD RELEASE CYLINDER SUPPORT	
1-3	S35351001	1	シリンダロッド	CYLINDER ROD	
3	S35305001	1	シリンダロッドピン	CYLINDER ROD PIN	
4	048030342	2	トメワE3	RETAINING RING, E3	
5	S10243000	1	ナイロンクランプNK-3N	CORD HOLDER (NK-3N)	
6	062400812	1	ナベコ4X8	SCREW, PAN M4X8	
7	S35350000	2	シリンダ16X10	CYLINDER 16X10	
8	S44530000	1	シリンダ16X15クミA	CYLINDER 16X15 ASSY (A)	
8-1	S12150000	2	ホースエルボM-5HL-4	TUBE ELBOW, M-5HL-4	
9	S43772000	1	シリンダ16X30クミB	CYLINDER 16X30 (B) ASSY	
9-1	S12150000	1	ホースエルボM-5HL-4	TUBE ELBOW (M-5HL-4)	
9-2	S43357000	1	シタOFFセンサコード	LOWER OFF SENSOR CORD	
9-3	S11433000	1	ホースニツブル4M5	HOSE NIPPLE (4M5)	
10	S43731001	1	シリンダ10X15クミ	CYLINDER 10X15 ASSY	
10-1	S12150000	2	ホースエルボM-5HL-4	TUBE ELBOW (M-5HL-4)	
10-3	S35351001	1	シリンダロッド	CYLINDER ROD	
10-4	S34916001	1	シリンダササエ	CYLINDER SUPPORT	
12	S35305001	1	シリンダロッドピン	CYLINDER ROD PIN	
13	048030342	2	トメワE3	RETAINING RING, E3	
14	S35360000	1	シリンダ63X100クミ	CYLINDER 63X100 ASSY	
14-1	S35426000	2	エルボ10-4	ELBOW 10-4	
15	S35417000	1	エア-ホース10X6.5-11(L=1100)	AIR TUBE 10X6.5-11 (L=1100)	
16	S35909000	1	エア-ホース10X6.5-18(L=1100)	AIR TUBE 10X6.5-18 (L=1100)	
17	S35367000	1	エア-ホース4X2.5-9(L=1130)	AIR TUBE 4X2.5-9 (L=1130)	
18	S35368000	1	エア-ホース4X2.5-10(L=1090)	AIR TUBE 4X2.5-10 (L=1090)	
19	S35369000	1	エア-ホース4X2.5-7(L=1150)	AIR TUBE 4X2.5-7 (L=1150)	
20	S35370000	1	エア-ホース4X2.5-8(L=1100)	AIR TUBE 4X2.5-8 (L=1100)	
21	S35371000	1	エア-ホース4X2.5-14(L=1370)	AIR TUBE 4X2.5-14 (L=1370)	
22	S35372000	1	エア-ホース4X2.5-17(L=1595)	AIR TUBE 4X2.5-17 (L=1595)	
24	S35374000	1	エア-ホース4X2.5-1(L=100)	AIR TUBE 4X2.5-1 (L=100)	
25	S35375000	1	エア-ホース4X2.5-12(L=360)	AIR TUBE 4X2.5-12 (L=360)	
26	S35376000	1	エア-ホース4X2.5-13(L=320)	AIR TUBE 4X2.5-13 (L=320)	
27	S35377100	1	エア-ホース4X2.5-3(L=1405)	AIR TUBE 4X2.5-3 (L=1405)	
28	S35378100	1	エア-ホース4X2.5-4(L=1355)	AIR TUBE 4X2.5-4 (L=1355)	
29	S35398100	1	エア-ホース4X2.5-5(L=1440)	AIR TUBE 4X2.5-5 (L=1440)	
30	S35399100	1	エア-ホース4X2.5-6(L=1490)	AIR TUBE 4X2.5-6 (L=1490)	
31	S44531000	1	シリンダ16X15クミB	CYLINDER ASSY 16X15 ASSY (B)	
31-1	S44532000	2	ホースニツブルクミ	TUBE NIPPLE ASSY	
31-1-1	S44532000	1	ユニバーサルチー	UNIVERSAL T-JOINT	
31-1-2	S11433000	2	ホースニツブル4M5	TUBE NIPPLE 4M5	
32	S12104000	1	ユニオンワイ4	UNION-Y 4	
34	158581000	2	コードホルダ#24	CORD HOLDER (24N)	
35	032422003	2	マルモクネジ4.1X20	WOOD SCREW, ROUND M4.1X20	
36	S11817000	1	クランプNK-18N	CLAMP NK-18N	
37	062400816	1	ナベコ4X8	SCREW, PAN M4X8	
38	S04557000	7	バンタイPLTIM	BAND PLTIM	
39	340400001	4	ユニタイバンド	BEAD BAND	
40	152969001	1	コードササエカネ	CORD SUPPORT	
41	062350616	1	ナベコM3.5X6	SCREW, PAN M3.5X6	
44	S35460000	2	スピコン	SPEED CONTROLLER	
45	S13955000	2	エアマフラ	AIR BOLSTER	
55	S37863000	1	エア-ホース4X2.5-3J	AIR TUBE 4X2.5-21 (L=100)	
56	S37864000	1	エア-ホース4X2.5-4J	AIR TUBE 4X2.5-21 (L=100)	
57	S12104000	2	ユニオンワイ4	UNION-Y 4	
58	S40677000	1	エア-ホース4X2.5-22	AIR TUBE 4X2.5-22	
59	S40676000	1	バブエルボM5ALN4	VALVE ELBOW M5ALN4	
60	S11816000	2	クランプNK-2N	CLAMP, NK-2N	

From the library of: Diamond Needle Corp

V. 空圧関係 / Air pressure mechanism / Luftdruck / Mécanisme de la pression d'air / Mecanismo de la presión de aire

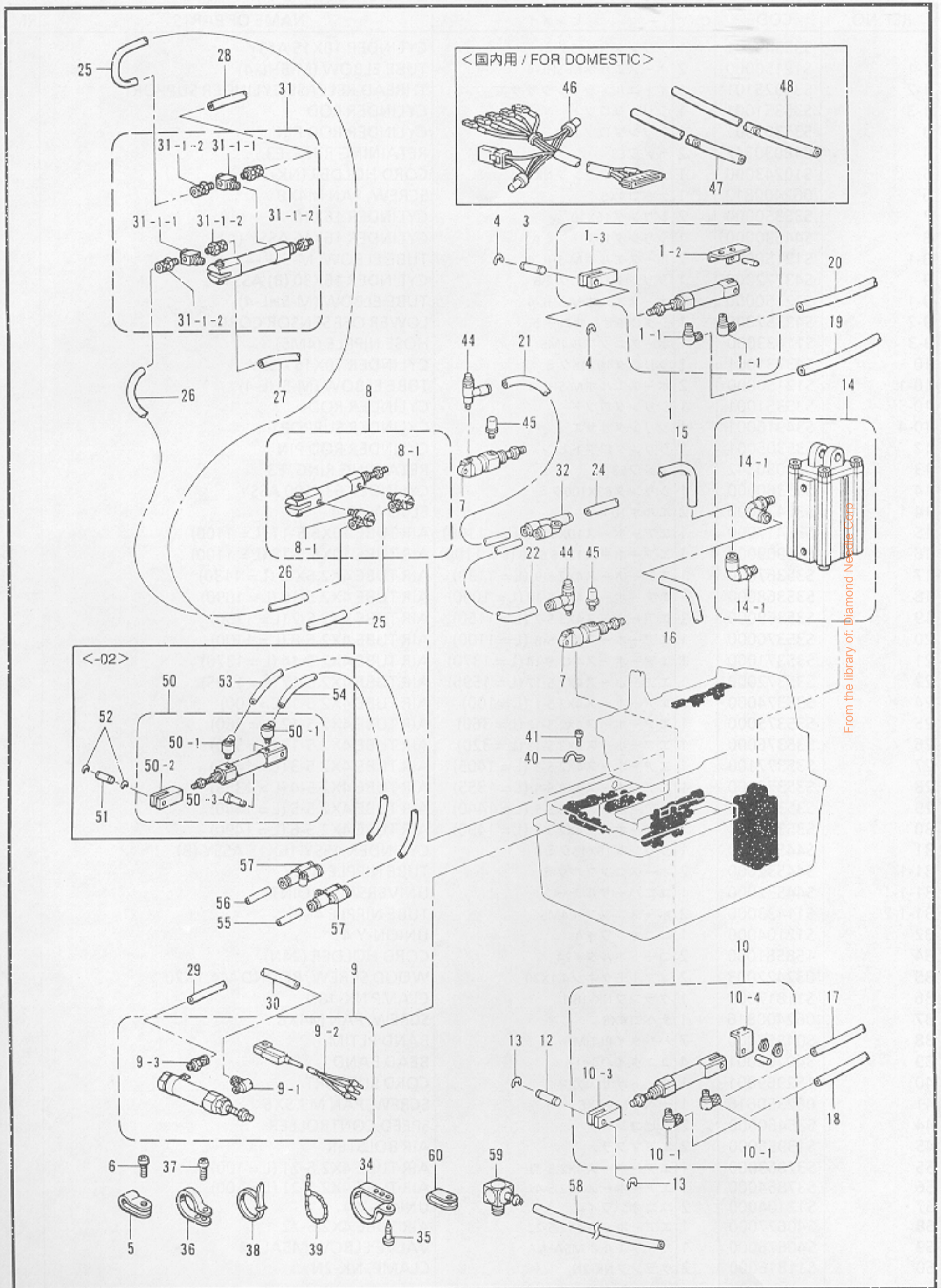

V. 空圧関係 / Air pressure mechanism / Luftdruck /  
 Mécanisme de la pression d'air / Mecanismo de la presión de aire

REF.NO.	CODE	Q'TY	品名	NAME OF PARTS	RM
<-02>					
50	S37737001	1	シリンダ10X15Jクミ	CYLINDER	
50-1	S12150000	2	ホースエルボM-5HL-4	TUBE ELBOW (M-5HL-4)	
50-2	S35351-001	1	シリンダロッド	CYLINDER ROD	
50-3	S37866-000	1	クレビスピン	CLEVIS PIN	
51	S35305001	1	シリンダロッドピン	CYLINDER ROD PIN	
52	048030342	2	トメワE3	RETAINING RING, E3	
53	S37738000	1	エアーホース4X2.5-20	AIR TUBE 4X2.5-20 (L = 1350)	
54	S37739000	1	エアーホース4X2.5-21	AIR TUBE 4X2.5-21 (L = 1400)	
<国内用 / FOR DOMESTIC>					
46	S43344000	1	バルブコードクミ	VALVE CORD ASSY	
47	S43769000	1	エアーホース10X6.5-15	AIR TUBE 10X6.5-15	
48	S43770000	1	エアーホース10X6.5-16	AIR TUBE 10X6.5-16	
42-3-1-1	S42683001	1	バルブ	SOLENOID VALVE	
42-3-1-2	S42223000	1	エアーホース	SOLENOID VALVE ASSY	
42-3-1-3	S44224000	1	エアーホース	ELBOW	
42-3-1-4	S22220000	1	エアーホース	AIR MUFFLER	
42-3-1-5	S44225000	1	エアーホース	PLUG	
42-3-1-6	S44226000	1	エアーホース	SCREW, PAN	
42-3-2	082405512	1	エアーホース	WASHER, SPRING 2-4	
42-3-3	028040246	1	エアーホース	AIR VALVE ASSY	
42-3-4	S44215000	1	エアーホース	AIR VALVE RCS2408	
42-3-4-1	S44216000	1	エアーホース	JOINT, 3109-10	
42-3-4-2	S44218000	1	エアーホース	AIR MAFLER, SL-2	
42-3-4-3	S44229000	1	エアーホース	VALVE ET02	
42-3-4-4	S44217000	1	エアーホース	JOINT, 1/4X1/4-M5	
42-3-4-5	S44218000	1	エアーホース	JOINT, 3199-4	
42-3-5	067403513	1	エアーホース	SCREW, PAN	
42-3-6	028040246	1	エアーホース	WASHER, SPRING 2-4	
42-3-7	026040246	1	エアーホース	WASHER, PLAIN S 4	
42-3-8	026040246	1	エアーホース	WASHER, PLAIN S 4	
42-3-9	S44215000	1	エアーホース	VALVE SET PLATE	
42-4	S34653202	1	エアーホース	WOOD SCREW IRD 8ASA M5	
42-5	S43769000	1	エアーホース10X6.5-15	AIR TUBE 10X6.5-15	
42-6	S43770000	1	エアーホース10X6.5-16	AIR TUBE 10X6.5-16	
42-7	S43344000	1	バルブコードクミ	VALVE CORD ASSY	

From the library of: Diamond Needle Corp



V. 空圧関係 / Air pressure mechanism / Luftdruck / Mécanisme de la pression d'air / Mecanismo de la presión de aire

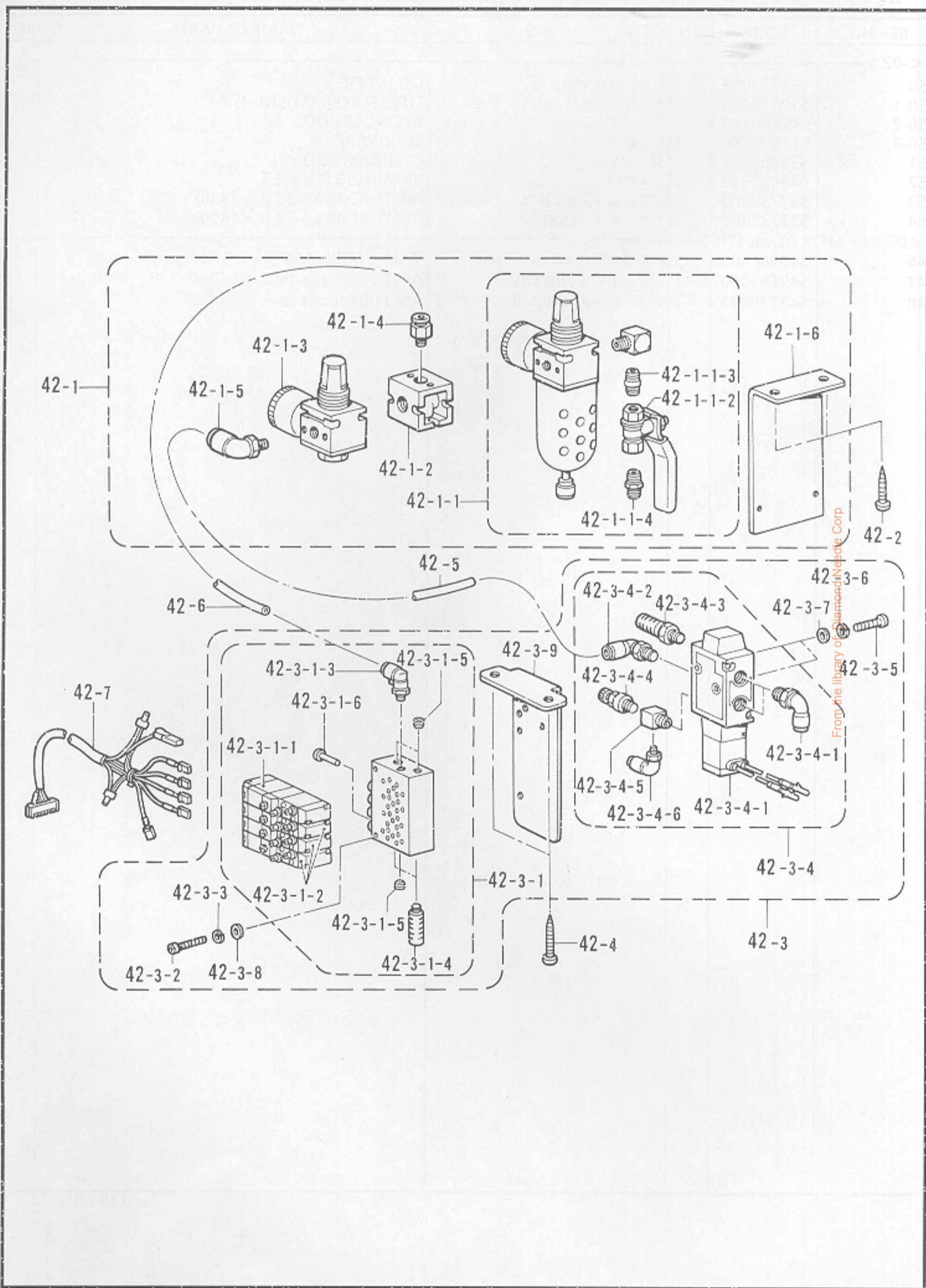

V. 空圧関係 / Air pressure mechanism / Luftdruck / Mécanisme de la pression d'air / Mecanismo de la presión de aire

REF.NO.	CODE	Q'TY	品名	NAME OF PARTS	RM
42-1	S35389001	1	エアユニットクミ	AIR UNIT ASSY	
42-1-1	S35386000	1	FRユニットクミ	(FR) UNIT ASSY	
42-1-1-1	S40628000	1	ボールバルブ1/4	BALL VALVE, 1/4	
42-1-1-2	S40629000	1	バレルニツブル	BARREL NIPPLE	
42-1-1-3	S40630000	1	ニツブル	NIPPLE	
42-1-2	S35382000	1	ダイバータ	DIVERter	
42-1-3	S35395000	1	レギュレータR55	REGULATOR (R55)	
42-1-4	S35423000	1	コネクタ10-3/8	CONNECTOR 10-3/8	
42-1-5	S35424000	1	エルボ10-1/4	ELBOW 10-1/4	
42-1-6	S35425001	1	エアユニットトリツケイタ	AIR UNIT SET PLATE	
42-2	031553202	2	マルモクネジ5.5X32	WOOD SCREW, ROUND M5.5X32	
42-3	S44213001	1	バルブユニット5クミ	VALVE UNIT ASSY, 5	
42-3-1	S44214000	1	ソレノイドバルブ5クミ	SOLENOID VALVE ASSY, 5	
42-3-1-1	S43683001	2	デンジバルブ	SOLENOID VALVE	
42-3-1-2	S44223000	3	デンジバルブ	SOLENOID VALVE	
42-3-1-3	S44224000	1	マイルエルボ10R-01ML	ELBOW 10R-01ML	
42-3-1-4	S23880000	2	エアマフラー	AIR MUFFLER	
42-3-1-5	S44225000	3	プラグR1/8	PLUG R1/8	
42-3-1-6	S44226000	1	プラグRP-4	PLUG RP-4	
42-3-2	062403512	2	ナベコ4X35	SCREW, PAN M4X35	
42-3-3	028040246	2	バネザガネ2-4	WASHER, SPRING 2-4	
42-3-4	S44215000	1	デンジベンクミ	AIR VALVE ASSY	
42-3-4-1	S44216000	1	デンジベンRCS2408	AIR VALVE RCS2408	
42-3-4-2	S44228000	3	ツギテ3109-10	JOINT, 3109-10	
42-3-4-3	S44229000	1	エアマフラーSL-2	AIR MAFLER, SL-2	
42-3-4-4	S44217000	1	スロットバルブET02	VALVE ET02	
42-3-4-5	S44218000	1	ツギテ1/4X1/4-M5	JOINT, 1/4X1/4-M5	
42-3-4-6	S44230000	1	ツギテ3199-4	JOINT, 3199-4	
42-3-5	062403512	2	ナベコ4X35	SCREW, PAN M4X35	
42-3-6	028040246	2	バネザガネ2-4	WASHER, SPRING 2-4	
42-3-7	026040136	2	ヒラザガネコガタ4	WASHER, PLAIN S 4	
42-3-8	026040136	2	ヒラザガネコガタ4	WASHER, PLAIN S 4	
42-3-9	S44219001	1	バルブトリツケイタ	VALVE SET PLATE	
42-4	031553202	2	マルモクネジ5.5X32	WOOD SCREW, ROUND M5.5X32	
42-5	S43769000	1	エアース10X6.5-15	AIR TUBE 10X6.5-15	
42-6	S43770000	1	エアース10X6.5-16	AIR TUBE 10X6.5-16	
42-7	S43344000	1	バルブコードクミ	VALVE CORD ASSY	
42-8	S43345000	1	バルブコードクミ	VALVE CORD ASSY	
42-9	S43346000	1	バルブコードクミ	VALVE CORD ASSY	
42-10	S43347000	1	バルブコードクミ	VALVE CORD ASSY	
42-11	S43348000	1	バルブコードクミ	VALVE CORD ASSY	
42-12	S43349000	1	バルブコードクミ	VALVE CORD ASSY	
42-13	S43350000	1	バルブコードクミ	VALVE CORD ASSY	
42-14	S43351000	1	バルブコードクミ	VALVE CORD ASSY	
42-15	S43352000	1	バルブコードクミ	VALVE CORD ASSY	
42-16	S43353000	1	バルブコードクミ	VALVE CORD ASSY	
42-17	S43354000	1	バルブコードクミ	VALVE CORD ASSY	
42-18	S43355000	1	バルブコードクミ	VALVE CORD ASSY	
42-19	S43356000	1	バルブコードクミ	VALVE CORD ASSY	
42-20	S43357000	1	バルブコードクミ	VALVE CORD ASSY	
42-21	S43358000	1	バルブコードクミ	VALVE CORD ASSY	
42-22	S43359000	1	バルブコードクミ	VALVE CORD ASSY	
42-23	S43360000	1	バルブコードクミ	VALVE CORD ASSY	
42-24	S43361000	1	バルブコードクミ	VALVE CORD ASSY	
42-25	S43362000	1	バルブコードクミ	VALVE CORD ASSY	
42-26	S43363000	1	バルブコードクミ	VALVE CORD ASSY	
42-27	S43364000	1	バルブコードクミ	VALVE CORD ASSY	
42-28	S43365000	1	バルブコードクミ	VALVE CORD ASSY	
42-29	S43366000	1	バルブコードクミ	VALVE CORD ASSY	
42-30	S43367000	1	バルブコードクミ	VALVE CORD ASSY	
42-31	S43368000	1	バルブコードクミ	VALVE CORD ASSY	
42-32	S43369000	1	バルブコードクミ	VALVE CORD ASSY	
42-33	S43370000	1	バルブコードクミ	VALVE CORD ASSY	
42-34	S43371000	1	バルブコードクミ	VALVE CORD ASSY	
42-35	S43372000	1	バルブコードクミ	VALVE CORD ASSY	
42-36	S43373000	1	バルブコードクミ	VALVE CORD ASSY	
42-37	S43374000	1	バルブコードクミ	VALVE CORD ASSY	
42-38	S43375000	1	バルブコードクミ	VALVE CORD ASSY	
42-39	S43376000	1	バルブコードクミ	VALVE CORD ASSY	
42-40	S43377000	1	バルブコードクミ	VALVE CORD ASSY	
42-41	S43378000	1	バルブコードクミ	VALVE CORD ASSY	
42-42	S43379000	1	バルブコードクミ	VALVE CORD ASSY	
42-43	S43380000	1	バルブコードクミ	VALVE CORD ASSY	
42-44	S43381000	1	バルブコードクミ	VALVE CORD ASSY	
42-45	S43382000	1	バルブコードクミ	VALVE CORD ASSY	
42-46	S43383000	1	バルブコードクミ	VALVE CORD ASSY	
42-47	S43384000	1	バルブコードクミ	VALVE CORD ASSY	
42-48	S43385000	1	バルブコードクミ	VALVE CORD ASSY	
42-49	S43386000	1	バルブコードクミ	VALVE CORD ASSY	
42-50	S43387000	1	バルブコードクミ	VALVE CORD ASSY	
42-51	S43388000	1	バルブコードクミ	VALVE CORD ASSY	
42-52	S43389000	1	バルブコードクミ	VALVE CORD ASSY	
42-53	S43390000	1	バルブコードクミ	VALVE CORD ASSY	
42-54	S43391000	1	バルブコードクミ	VALVE CORD ASSY	
42-55	S43392000	1	バルブコードクミ	VALVE CORD ASSY	
42-56	S43393000	1	バルブコードクミ	VALVE CORD ASSY	
42-57	S43394000	1	バルブコードクミ	VALVE CORD ASSY	
42-58	S43395000	1	バルブコードクミ	VALVE CORD ASSY	
42-59	S43396000	1	バルブコードクミ	VALVE CORD ASSY	
42-60	S43397000	1	バルブコードクミ	VALVE CORD ASSY	
42-61	S43398000	1	バルブコードクミ	VALVE CORD ASSY	
42-62	S43399000	1	バルブコードクミ	VALVE CORD ASSY	
42-63	S43400000	1	バルブコードクミ	VALVE CORD ASSY	
42-64	S43401000	1	バルブコードクミ	VALVE CORD ASSY	
42-65	S43402000	1	バルブコードクミ	VALVE CORD ASSY	
42-66	S43403000	1	バルブコードクミ	VALVE CORD ASSY	
42-67	S43404000	1	バルブコードクミ	VALVE CORD ASSY	
42-68	S43405000	1	バルブコードクミ	VALVE CORD ASSY	
42-69	S43406000	1	バルブコードクミ	VALVE CORD ASSY	
42-70	S43407000	1	バルブコードクミ	VALVE CORD ASSY	
42-71	S43408000	1	バルブコードクミ	VALVE CORD ASSY	
42-72	S43409000	1	バルブコードクミ	VALVE CORD ASSY	
42-73	S43410000	1	バルブコードクミ	VALVE CORD ASSY	
42-74	S43411000	1	バルブコードクミ	VALVE CORD ASSY	
42-75	S43412000	1	バルブコードクミ	VALVE CORD ASSY	
42-76	S43413000	1	バルブコードクミ	VALVE CORD ASSY	
42-77	S43414000	1	バルブコードクミ	VALVE CORD ASSY	
42-78	S43415000	1	バルブコードクミ	VALVE CORD ASSY	
42-79	S43416000	1	バルブコードクミ	VALVE CORD ASSY	
42-80	S43417000	1	バルブコードクミ	VALVE CORD ASSY	
42-81	S43418000	1	バルブコードクミ	VALVE CORD ASSY	
42-82	S43419000	1	バルブコードクミ	VALVE CORD ASSY	
42-83	S43420000	1	バルブコードクミ	VALVE CORD ASSY	
42-84	S43421000	1	バルブコードクミ	VALVE CORD ASSY	
42-85	S43422000	1	バルブコードクミ	VALVE CORD ASSY	
42-86	S43423000	1	バルブコードクミ	VALVE CORD ASSY	
42-87	S43424000	1	バルブコードクミ	VALVE CORD ASSY	
42-88	S43425000	1	バルブコードクミ	VALVE CORD ASSY	
42-89	S43426000	1	バルブコードクミ	VALVE CORD ASSY	
42-90	S43427000	1	バルブコードクミ	VALVE CORD ASSY	
42-91	S43428000	1	バルブコードクミ	VALVE CORD ASSY	
42-92	S43429000	1	バルブコードクミ	VALVE CORD ASSY	
42-93	S43430000	1	バルブコードクミ	VALVE CORD ASSY	
42-94	S43431000	1	バルブコードクミ	VALVE CORD ASSY	
42-95	S43432000	1	バルブコードクミ	VALVE CORD ASSY	
42-96	S43433000	1	バルブコードクミ	VALVE CORD ASSY	
42-97	S43434000	1	バルブコードクミ	VALVE CORD ASSY	
42-98	S43435000	1	バルブコードクミ	VALVE CORD ASSY	
42-99	S43436000	1	バルブコードクミ	VALVE CORD ASSY	
42-100	S43437000	1	バルブコードクミ	VALVE CORD ASSY	

From the library of: Diamond Needle Corp

W. 電装品関係 / Power supply equipment mechanism / Stromversorgung / Mécanisme de l'équipement en alimentation électrique / Mecanismo del equipo de alimentación de corriente

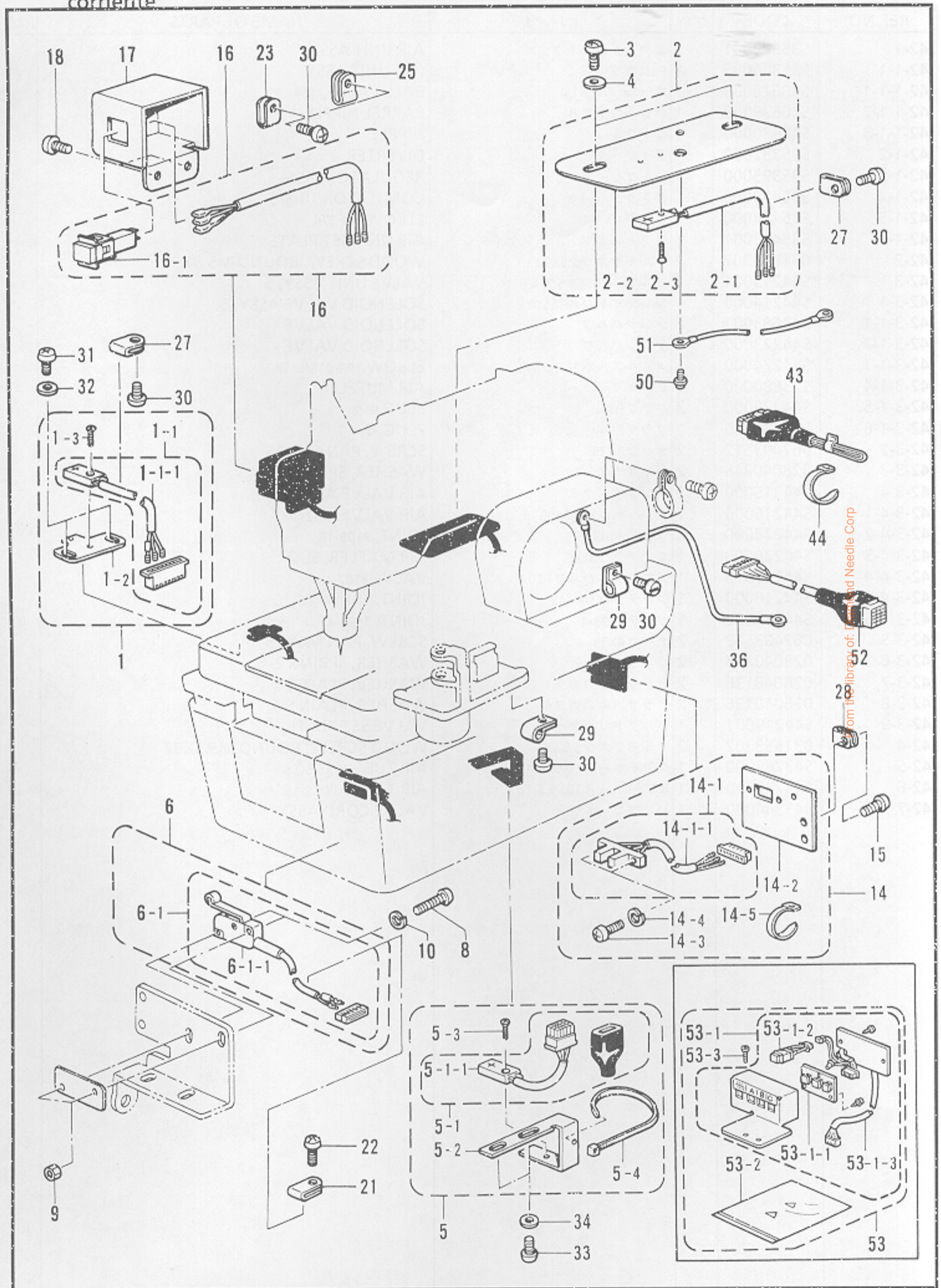

W. 電装品関係 / Power supply equipment mechanism / Stromversorgung / Mécanisme de l'équipement en alimentation électrique / Mecanismo del equipo de alimentación de corriente

REF.NO.	CODE	QTY	ヒンメイ	NAME OF PARTS	RM
1	S43320001	1	XセンサクミB	X-SENSOR ASSY (B)	
1-1	S43321000	1	XORGコードクミ	XORG CORD ASSY	
1-1-1	S43322000	1	XORGコード	XORG CORD	
1-2	S35185101	1	Xセンサトリツケイタ	X-SENSOR SET PLATE	
1-3	S10856001	1	+サラネジ2X8	SCREW, FLAT M2X8	
2	S43323001	1	YセンサクミB	Y-SENSOR ASSY (B)	
2-1	S43324000	1	YORGコード	YORG CORD	
2-2	S10856001	1	+サラネジ2X8	SCREW, FLAT M2X8	
2-3	S35164001	1	Yセンサトリツケイタ	Y-SENSOR SET PLATE	
3	062400812	2	ナベコ4X8	SCREW, PAN M4X8	
4	025040234	2	ヒラザガネチユウ4	WASHER, PLAIN M 4	
5	S43325001	1	RセンサクミB	R-SENSOR ASSY	
5-1	S43326000	1	RORGコードクミ	RORG CORD ASSY	
5-1-1	S35154000	1	Rセンサ	R-SENSOR	
5-2	S35298001	1	Rセンサトリツケイタ	R-SENSOR SET PLATE	
5-3	S10856001	1	+サラネジ2X8	SCREW, FLAT M2X8	
5-4	S04557000	1	バンドイPLTIM	BAND, PLTIM	
6	S43328000	1	アンゼンSWコードクミ	SAFETY SWITCH CORD ASSY	
6-1	S43329000	1	アンゼンSWコード	SAFETY SWITCH CORD	
6-1-1	S10546000	1	スイッチD2MVローラ	SWITCH (D2MV) ROLLER	
7	025030232	2	ヒラザガネチユウ3	WASHER, PLAIN M 3	
8	062301606	2	ナベコ3X16	SCREW, PAN M3X16	
9	021300206	2	2シユナツト3	NUT, 2 M3	
10	028030243	2	バネザガネ2-3	WASHER, SPRING 2-3	
14	S43330001	1	カッターセンサークミB	CUTTER SENSOR ASSY (B)	
14-1	S43331000	1	カッターセンサーコードクミ	CUTTER SENSOR CORD ASSY	
14-1-1	S43332000	1	カッターセンサーコード	CUTTER SENSOR CORD	
14-2	S35162001	1	カッターセンサートリツケイタ	CUTTER SENSOR SET PLATE	
14-3	062300806	2	ナベコ3X8	SCREW, PAN M3X8	
14-4	028030243	2	バネザガネ2-3	WASHER, SPRING 2-3	
14-5	S04557000	1	バンドイPLTIM	BAND, PLTIM	
15	062400812	2	ナベコ4X8	SCREW, PAN M4X8	
16-1	S43333000	1	EMSWクミ	EMSW ASSY	
17-1	S35165009	1	スイッチカバー	SWITCH COVER	
18	062400812	2	ナベコ4X8	SCREW, PAN M4X8	
21-1	S11816000	3	クランプNK-2N	CLAMP, NK-2N	
22	062400812	3	ナベコ4X8	SCREW, PAN M4X8	
23	S10243000	2	ナイロンクランプNK-3N	CORD HOLDER, NK-3N	
25	S10243000	2	ナイロンクランプNK-3N	CORD HOLDER, NK-3N	
27	S11816000	2	クランプNK-2N	CLAMP, NK-2N	
28	S10243000	1	ナイロンクランプNK-3N	CORD HOLDER, NK-3N	
29	552907000	2	コードホルダ#10	CORD HOLDER, 10N	
30	062400812	6	ナベコ4X8	SCREW, PAN M4X8	
31	062400812	3	ナベコ4X8	SCREW, PAN M4X8	
32	025040232	2	ヒラザガネチユウ4	WASHER, PLAIN M 4	
33	062400812	2	ナベコ4X8	SCREW, PAN M4X8	
34	025040232	2	ヒラザガネチユウ4	WASHER, PLAIN M 4	
42	062401212	1	ナベコ4X12	SCREW, PAN M4X12	
43	※	1	シヨウハーネス	HARNESS	
44	S04557000	2	バンドイPLTIM	BAND, PLTIM	
50	052400606	1	ナベコバネヒラ4X6	SCREW, PAN (S/P WASHER) M4X6	
51	S44287000	4	アースセン1050	EARTH WIRE (1050)	
52	S43358000	1	センサチユウケイコード	SENSOR CONNECTING CORD	
53	S45043009	1	キリカエスイッチソウクミ	SELECT SWITCH SET	
53-1	S44551009	1	キリカエスイッチクミ	SELECT SWITCH ASSY	
53-1-1	S38051000	1	OPキバンクミ	OP PCB ASSY	
53-1-2	S44944000	1	リセットスイッチクミ	RESET SWITCH ASSY	
53-1-3	S44943000	1	キリカエスイッチコード	SELECT SWITCH CORD	
53-2	164348001	1	PEフクロ200X300	PE BAG	
53-3	060400816	1	バインド4X8	SCREW, BIND M4X8	

From the library of: Diamond Needle Corp

X. 踏板關係 / Foot switch pedal mechanism / Fußbetätigung / Mécanisme de la pédale / Mecanismo del pedal

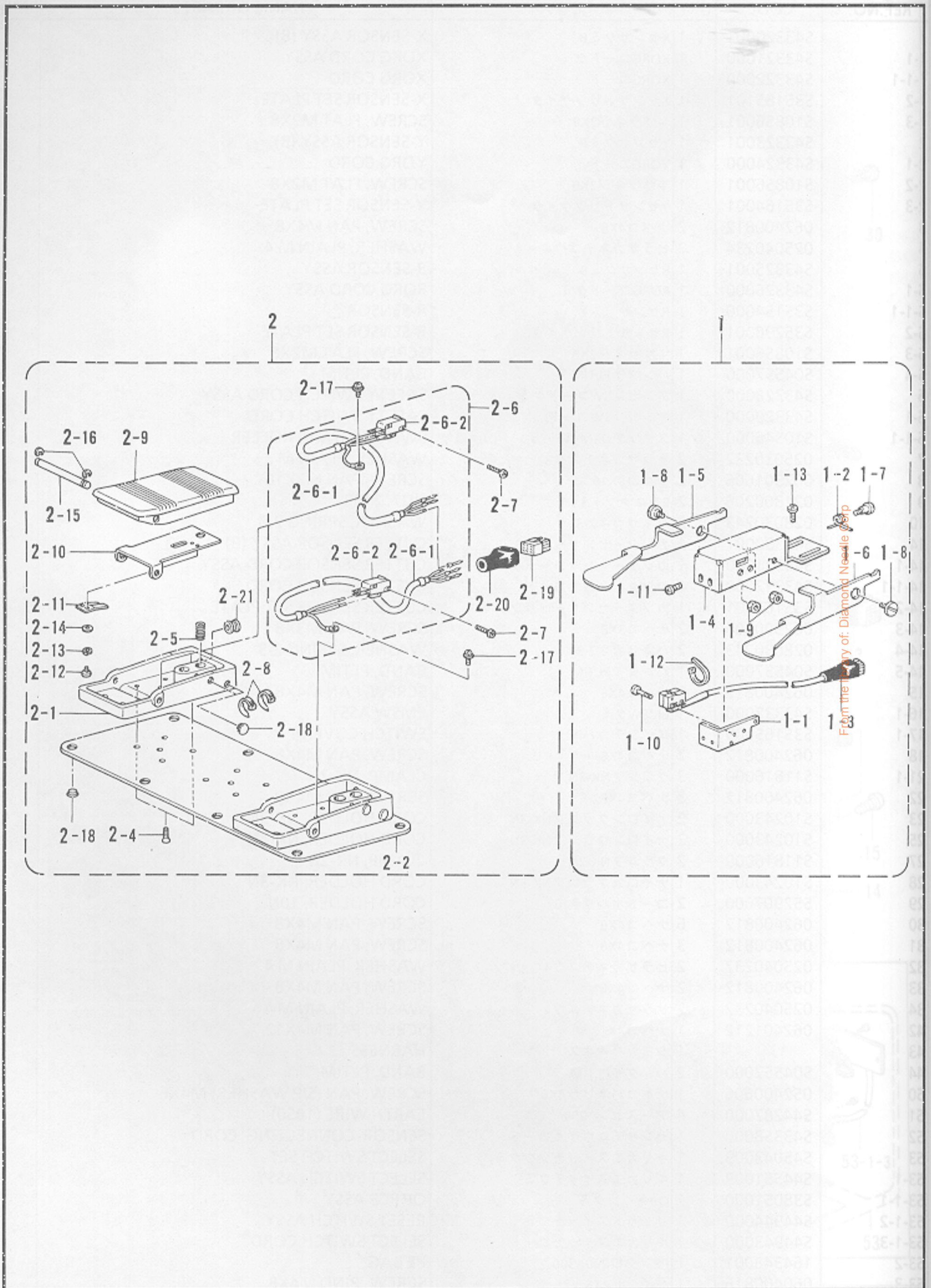

X. 踏板関係 / Foot switch pedal mechanism / Fußbetätigung / Mécanisme de la pédale / Mecanismo del pedal

REF.NO.	CODE	Q'TY	ヒンメイ	NAME OF PARTS	RM
<-02>					
1	S43346001	1	テモトスイッチクミB	HAND START SWITCH ASSY(B)	
1-1	S39913001	1	スイッチトリツケイタ	SWITCH SET PLATE	
1-2	S39914001	1	スイッチレバーバネ	SPRING, SWITCH LEVER	
1-3-1	S43345000	1	テモトスイッチB	HAND SWITCH (B)	
1-4	S39910001	1	スイッチカバー	SWITCH COVER	
1-5	S39911001	1	スイッチレバーL	SWITCH LEVER, L	
1-6	S39912001	1	スイッチレバーR	SWITCH LEVER, R	
1-7	S34922101	1	ダンネジM4	SHOULDER SCREW, M4	
1-8	S34966001	2	ダンネジM4	SHOULDER SCREW, M4	
1-9	021400202	3	2シユナツト4	NUT, 2 M4	
1-10	146124001	2	シメネジ2.38	SCREW, SM2.38	
1-11	060300616	2	バインド3X6	SCREW, BIND M3X6	
1-12	S04557000	1	バンタイPLTIM	BAND, PLTIM	
1-13	060400816	2	バインド4X8	SCREW, BIND M4X8	
<-52>					
2	S42838001	1	2レンフット2SW	2-PEDAL FOOT SWITCH, 2	
2-1	S38166000	2	フットペダルダイ	FOOT PEDAL STAND	
2-2	S42867001	1	フミイタホジヨイタ	TREADLE AUXILIARY PLATE	
2-3	004400803	4	+サラネジ4X8	SCREW, FLAT M4X8	
2-4	S38170001	2	フットペダルバネ	FOOT PEDAL SPRING	
2-5	S38029000	2	2レンフットSWハーネスクミ	2-PEDAL FOOT SW HARNESS ASSY	
2-5-1	S38030000	2	2レンフットSWハーネス	2-PEDAL FOOT SW HARNESS	
2-5-2	S36260000	2	スイッチVXピンボタン	SWITCH PIN BUTTON, VX	
2-6	062301205	4	ナベコ3X12	SCREW, PAN M3X12	
2-7	228475000	10	ケツソクバンド1.9X80	FASTENING BAND, 1.9X80	
2-8	S38174000	2	フットペダル	FOOT PEDAL	
2-9	S38175001	2	ペダルホゴイタ	PEDAL PROTECTION PLATE	
2-10	S38176001	2	スイッチオサエバネ	SPRING, SWITCH PRESSER	
2-11	002300403	4	+ナベコ3X4	SCREW, PAN M3X4	
2-12	028030246	4	バネザガネ2-3	WASHER, SPRING 2-3	
2-13	025030236	4	ヒラザガネチユウ3	WASHER, PLAIN M 3	
2-14	S38177001	2	フットペダルジケ	FOOT PEDAL SHAFT	
2-15	048050346	4	トメワE5	RETAINING RING, E5	
2-16	052400606	2	ナベコバネヒラ4X6	SCREW, PAN (S/P WASHER) M4X6	
2-17	117936001	12	ゴムセン9.4	RUBBER CAP, 9.4	
2-18	S38180000	1	コネクタ172169-1	CONNECTOR, 172169-1	
2-19	S38060000	1	コネクタキヤツブ18X19	CONNECTOR CAP, 18X19	
2-20	S38059000	2	グロメツトNG79F	RUBBER CAP, NG79F	
2-21	S42401236	4	ソルトソケットM4X8	SOLT SOCKET M4X8	
2-22	S42829100	9	フィードバーガイド	FEED BAR GUIDE	
2-23	018400830	2	ソルトソケット4X8	SOLT, SOCKET 4X8	
2-24	S42132000	1	フィードベース	FEED BASE	
2-25	S42133000	1	シリンダ10X5	CYLINDER 10X5	
2-26	S42114000	6	シリンダ10X5	CYLINDER 10X5	
2-27	S11433000	1	ボスニールフル4M5	BOSS NIEL FULL 4M5	
2-28	S05356000	1	ボタンプレス	BUTTON PRESS	
2-29	S42134000	1	フィードバーガイドR2	FEED BAR GUIDE (R) ASSY	
2-30	S42135000	1	フットスイッチクミ	FOOT SWITCH ASSY	
2-31	S36261000	2	スイッチVXロリ	SWITCH VXR ROLLER LEVER	
2-32	062301214	2	ナベコM3X14	SCREW, PAN M3X14	
2-33	060480516	2	バインドM4X5	SCREW, BIND M4X5	
2-34	S42137000	2	クランプ	CLAMP	
2-35	S42138000	2	クランプ	CLAMP	
2-36	003300012	2	ナベコM3X8	SCREW, FLAT M3X8	
2-37	S42139000	3	ナベコM3X8	SCREW, FLAT M3X8	
2-38	S42140100	1	バインドM4X5	SCREW, BIND M4X5	
2-39	060400516	2	バインドM4X5	SCREW, BIND M4X5	

From the library of: Diamond Needle Corp

Y. 布制御関係 / Cloth control system mechanism / Stoffführungsrichtung / Mécanisme de la système de contrôle du tissu / Mecanismo de la sistema de control de tela

Y. 布制  
sys

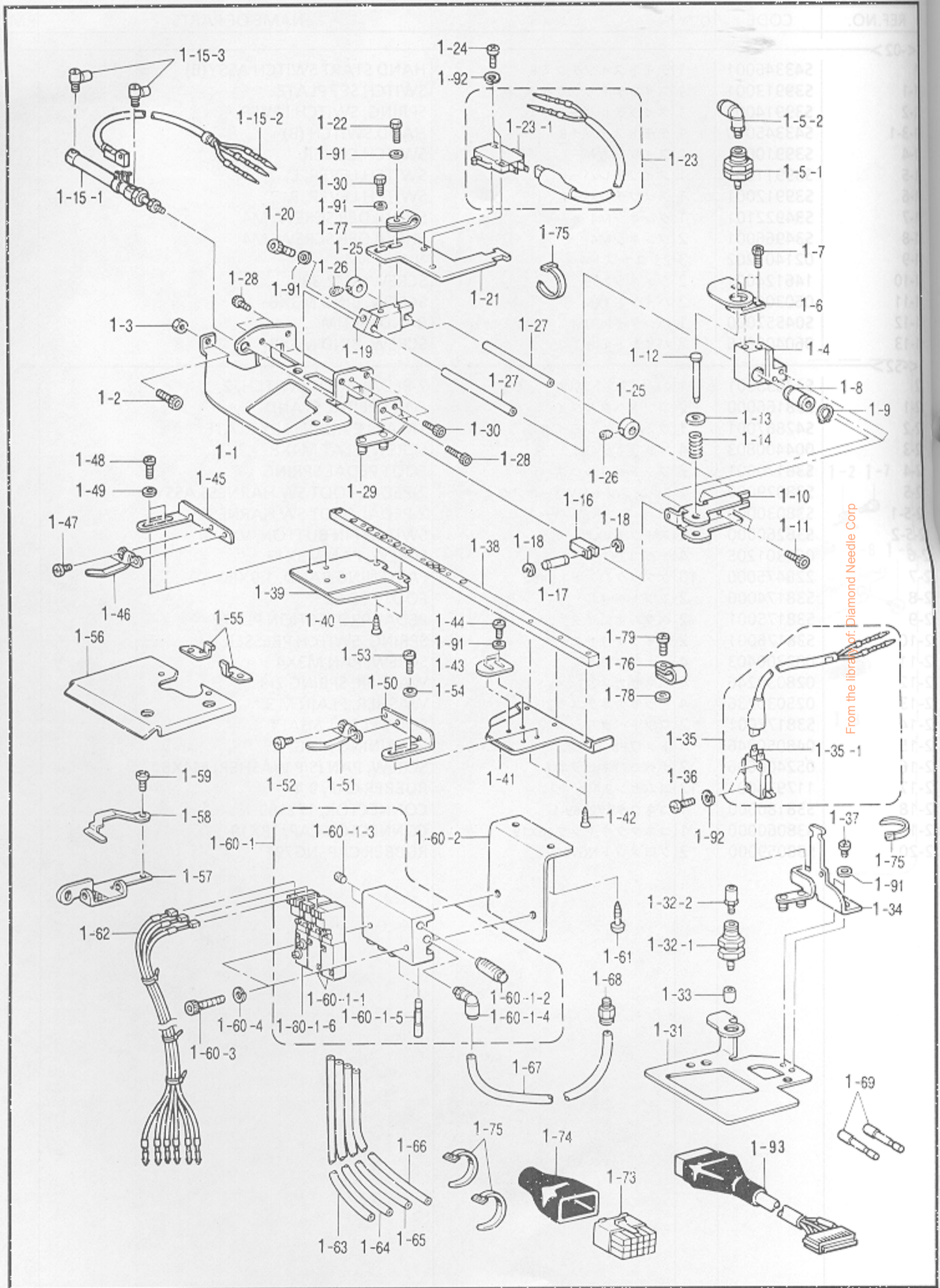

From the library of: Diamond Needle Corp

REF.
<L1,
1-46
1-41
<L3,
1-41
1-1
1-2
1-3
1-4
1-5
1-5-1
1-5-2
1-6
1-7
1-8
1-9
1-10
1-11
1-12
1-13
1-14
1-15
1-16
1-17
1-18
1-19
1-20
1-21
1-22
1-23
1-24
1-25
1-26
1-27
1-28
1-29
1-30
1-31
1-32
1-33
1-34
1-35
1-36
1-37
1-38
1-39
1-40
1-41
1-42
1-43
1-44
1-45
1-46
1-47
1-48
1-49
1-50
1-51
1-52
1-53
1-54
1-55
1-56
1-57
1-58
1-59
1-60
1-61
1-62
1-63
1-64
1-65
1-66
1-67
1-68
1-69
1-70
1-71
1-72
1-73
1-74
1-75
1-76
1-77
1-78
1-79
1-80
1-81
1-82
1-83
1-84
1-85
1-86
1-87
1-88
1-89
1-90
1-91
1-92
1-93

Y. 布制御関係 / Cloth control system mechanism / Stoffführungsrichtung / Mécanisme de la système de contrôle du tissu / Mecanismo de la sistema de control de tela

REF.NO.	CODE	Q'TY	ヒンメイ	NAME OF PARTS	RM
<L1, L2, L5>					
1-46	S44279001	1	981インデクサーソウクミ	FLY INDEXER ASSY, 981	
1-41	S43809001	1	ヌノオクリイタR-L1L2	CLOTH FEED PLATE R-L1L2	
<L3, L4, L6, L7>					
1-49	S44281001	1	981インデクサーソウクミ	FLY INDEXER ASSY, 981	
1-41	S42139101	1	ヌノオクリイタR	CLOTH FEED PLATE R	
1-1	S42111101	1	オクリドダイL	FEED BASE (L)	
1-2	018501636	1	アナボルト5X16	BOLT, SOCKET M5X16	
1-3	021500216	1	2シユナツト5	NUT, 2 M5	
1-4	S42112100	1	オクリドウブロック	FEED MOVABLE BLOCK	
1-5	S42113000	1	シリンダ10X5エルボクミ	CYLINDER ELBOW 10X5 ASSY	
1-5-1	S42114000	1	シリンダ10X5	CYLINDER 10X5	
1-5-2	S11426000	1	エルボユニオン4M5	ELBOW UNION, 4M5	
1-6	S42115101	1	シリンダトリツケイタ	CYLINDER SET PLATE	
1-7	018401236	2	アナボルト4X12	BOLT, SOCKET M4X12	
1-8	S42116000	1	リニアボールベアリング	LINEAR BALL BEARING	
1-9	048120142	1	トメワジクヨウC12	RETAINING RING, C12	
1-10	S42117101	1	チャツクピンガイドイタ	CHUCK PIN GUIDE PLATE	
1-11	018401236	2	アナボルト4X12	BOLT, SOCKET M4X12	
1-12	S42118001	1	チャツクピン	PIN	
1-13	026040136	1	ヒラザガネコガタ4	WASHER, PLAIN S 4	
1-14	S42119001	1	オシバネ	SPRING	
1-15	S42120100	1	シリンダ10X60クミ	CYLINDER 10X60 ASSY	
1-15-1	S42121000	1	シリンダ10X60	CYLINDER 10X60	
1-15-2	S42122000	1	シリンダセンサ	CYLINDER SENSOR	
1-15-3	S12150000	2	ホースエルボM-5HL-4	TUBE ELBOW, M-5HL-4	
1-16	S42123001	1	シリンダロッド	CYLINDER ROD	
1-17	S42124001	1	シリンダロッドピン	CYLINDER ROD PIN	
1-18	048030342	2	トメワE3	RETAINING RING, E3	
1-19	S42125100	1	オクリテイシブロック	STOP BLOCK	
1-20	018401636	1	アナボルト4X16	BOLT, SOCKET M4X16	
1-21	S42126101	1	スイッチトリツケイタ	SWITCH SET PLATE	
1-22	018401236	1	アナボルト4X12	BOLT, SOCKET M4X12	
1-23	S42127000	1	リミットスイッチクミL	LIMIT SWITCH ASSY (L)	
1-23-1	S36261000	1	スイッチVXローラレバー	SWITCH (VX) ROLLER LEVER	
1-24	062301414	2	ナベコM3X14	SCREW, PAN M3X14	
1-25	S24325001	2	セットカラー	SET SCREW COLLAR	
1-26	014400532	2	アナクボミ4X5	SET SCREW, SOCKET (CP) M4X5	
1-27	S42128101	2	オクリガイドジク	FEED GUIDE SHAFT	
1-28	018401236	4	アナボルト4X12	BOLT, SOCKET M4X12	
1-29	S42129101	1	オクリボウガイドLクミ	FEED BAR GUIDE (L) ASSY	
1-30	018400836	2	アナボルト4X8	BOLT, SOCKET M4X8	
1-31	S42132001	1	オクリドダイR	FEED BASE (R)	
1-32	S42133000	1	シリンダ10X5クミ	CYLINDER 10X5 ASSY	
1-32-1	S42114000	1	シリンダ10X5	CYLINDER 10X5	
1-32-2	S11433000	1	ホースニツブル4M5	HOSE NIPPLE, 4M5	
1-33	S05356000	1	ボタンオサエA	BUTTON PRESSER, A	
1-34	S42134101	1	オクリボウガイドRクミ	FEED BAR GUIDE (R) ASSY	
1-35	S42136000	1	リミットスイッチクミR	LIMIT SWITCH ASSY	
1-35-1	S36261000	1	スイッチVXローラレバー	SWITCH (VX) ROLLER LEVER	
1-36	062301414	2	ナベコM3X14	SCREW, PAN M3X14	
1-37	060400516	2	バインドM4X5	SCREW, BIND M4X5	
1-38	S42137001	1	ヌノオクリボウ	CLOTH FEED BAR	
1-39	S42138101	1	ヌノオクリイタL	CLOTH FEED PLATE	
1-40	003300812	2	サラネジ3X8	SCREW, FLAT M3X8	
1-42	003300812	3	サラネジ3X8	SCREW, FLAT M3X8	
1-43	S42140100	1	ヌノセットガイドタテ	VERTICAL CLOTH SET GUIDE	
1-44	060400516	2	バインドM4X5	SCREW, BIND M4X5	



Y. 布制御関係 / Cloth control system mechanism / Stoffführungsvorrichtung / Mécanisme de la système de contrôle du tissu / Mecanismo de la sistema de control de tela

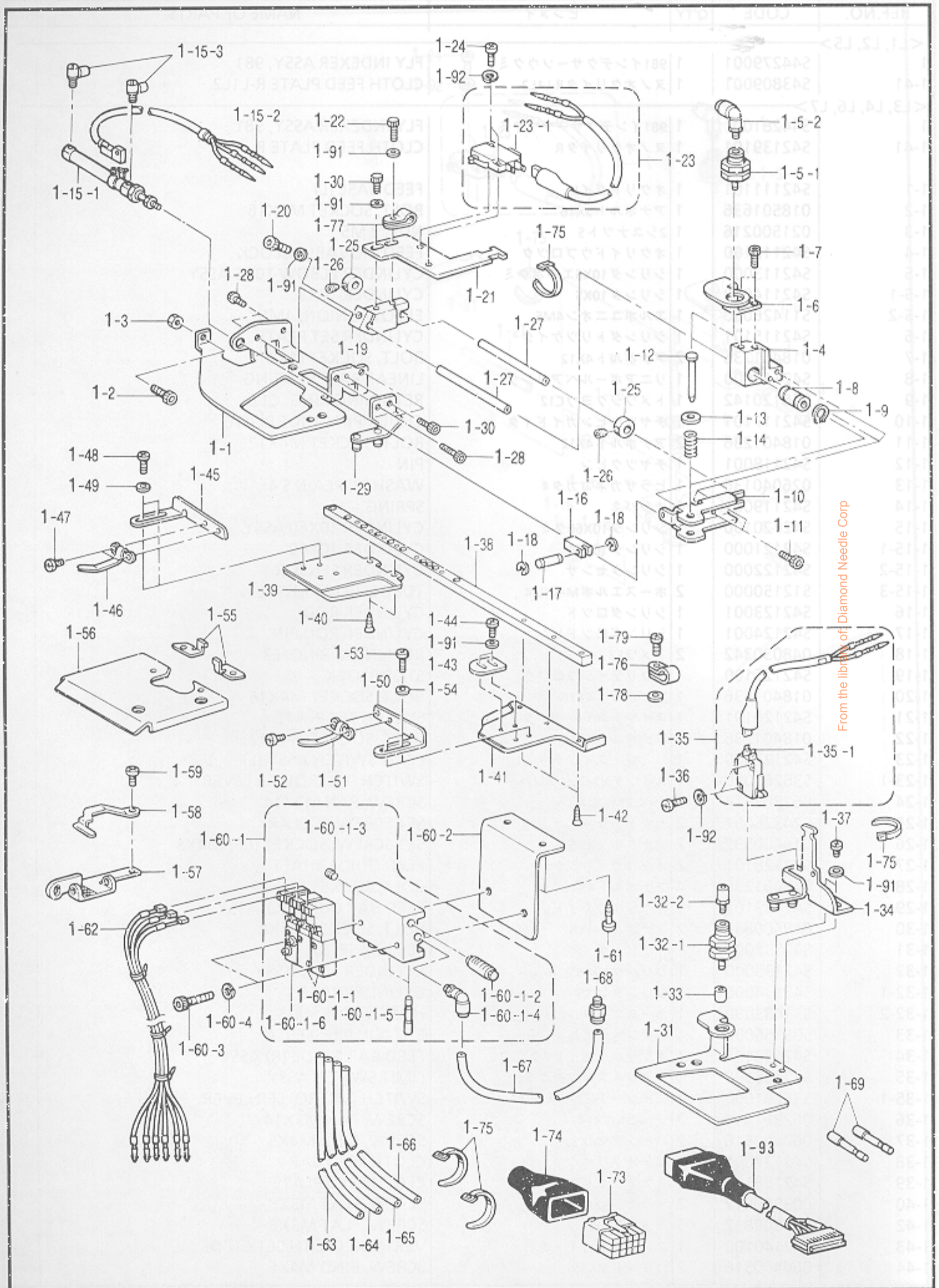

From the library of Diamond Needle Corp

Y. 布制御関係 / Cloth control system mechanism / Stoffführungsrichtung / Mécanisme de la système de contrôle du tissu / Mecanismo de la sistema de control de tela

REF.NO.	CODE	Q'TY	ヒンメイ	NAME OF PARTS	RM
1-45	S42141100	1	ヌノセットガイドヨコL	HORIZONTAL CLOTH SET GUIDE (L)	
1-46	S42143100	1	イタバネ	SPRING	
1-47	060300416	2	バインド3X4	SCREW, BIND M3X4	
1-48	060400416	2	バインドM4X4	SCREW, BIND M4X4	
1-49	025040234	2	ヒラザガネチユウ4	WASHER, PLAIN M 4	
1-50	S42142100	1	ヌノセットガイドヨコR	HORIZONTAL CLOTH SET GUIDE (R)	
1-51	S42143100	1	イタバネ	SPRING	
1-52	060300416	2	バインド3X4	SCREW, BIND M3X4	
1-53	060400416	2	バインドM4X4	SCREW, BIND M4X4	
1-54	025040234	2	ヒラザガネチユウ4	WASHER, PLAIN M 4	
1-55	S42144101	2	プレートオサエI	PLATE PRESSER (i)	
1-56	S42145001	1	オサエプレートI	PRESSER PLATE (I)	
1-57	S41451001	1	ウワイトオサエササエ	UPPER THREAD PRESSER SUPPORT	
1-58	S41452000	1	ウワイトオサエイタ	UPPER THREAD PRESSER PLATE	
1-59	062350516	1	ナベコ3.5X5	SCREW, PAN M3.5X5	
1-60	S42146101	1	バルブユニットソウクミ	VALVE UNIT SET	
1-60-1	S42147101	1	バルブユニットクミ	VALVE UNIT ASSY	
1-60-1-1	S39115000	2	バルブVQZ1151-5	VALVE, VQZ1151-5	
1-60-1-2	140682001	1	サイレンサン	SILENCER	
1-60-1-3	153274001	2	1/8トメセン	CAP, 1/8	
1-60-1-4	S01542000	1	エルボユニオン61	ELBOW UNION, 61	
1-60-1-5	S04897000	2	プラグ4	PLUG, 4	
1-60-1-6	S39116000	1	バルブVQZ1151S-5	VALVE, VQZ1151S-5	
1-60-2	S42148101	1	バルブトリツケイタ	VALVE SET PLATE	
1-60-3	018503036	2	アナボルト5X30	BOLT, SOCKET M5X30	
1-60-4	028050243	2	バネザガネ2-5	WASHER, SPRING 2-5	
1-61	032422003	2	+マルモクネジ4.1X20	WOOD SCREW, ROUND M4.1X20	
1-62	S42149000	1	バルブハーネス	VALVE HARNESS	
1-63	S42150100	1	エアーホース4X2.5-50	AIR TUBE 4X2.5-50	
1-64	S42151100	1	エアーホース4X2.5-51	AIR TUBE 4X2.5-51	
1-65	S42152100	1	エアーホース4X2.5-52	AIR TUBE 4X2.5-52	
1-66	S42153000	1	エアーホース4X2.5-53	AIR TUBE 4X2.5-53	
1-67	S42154000	1	エアーホース6X4	AIR TUBE 6X4	
1-68	S01522000	1	ハーフユニオン	HALF UNION	
1-69	S04897000	2	プラグ4	PLUG, 4	
1-71	S02760000	1	ナイロンコネクタ	NYLON CONNECTOR	
1-72	S42156000	1	コネクタキャップ	CONNECTOR CAP	
1-73	S42157000	1	コネクタ5025-15R1	CONNECTOR 5025-15RT	
1-74	S42158000	1	コネクタキャップ	CONNECTOR CAP	
1-75	S04557000	8	バンタイPLTIM	BAND, PLTIM	
1-76	S00480000	2	コードホルダ#5	CORD HOLDER, 5N	
1-78	025060236	1	ヒラザガネチユウ6	WASHER, PLAIN M 6	
1-79	062401616	1	ナベコ4X16	SCREW, PAN M4X16	
1-91	025040234	7	ヒラザガネチユウ4	WASHER, PLAIN M 4	
1-92	028030243	4	バネザガネ2-3	WASHER, SPRING 2-3	
1-93	S43359000	1	インデクサチユウケイコード	INDEXER CORD	
50	018065022	4	ボルト、ソケットM6X50	BOLT, SOCKET M6X50	
51	028060242	4	ワッシャー、スプリング2-6	WASHER, SPRING 2-6	
52	122257001	4	ワッシャー	WASHER	
53	S43715001	1	モータープレート	MOTOR PLATE	
54	S43716001	1	ボルト、インジケーションプレート	BOLT, INDICATION PLATE	
55	018065022	4	ボルト、ソケットM6X50	BOLT, SOCKET M6X50	
56	028060242	4	ワッシャー、スプリング2-6	WASHER, SPRING 2-6	
57	152861101	1	モーターベースプレート	MOTOR BASE PLATE	
58	152862001	1	モーターベースプレートシャフト	MOTOR BASE PLATE SHAFT	
59	048100101	1	リテーニングリング、C10	RETAINING RING, C10	
60	152865201	1	ベルト調整ロッド、M10	BELT ADJUSTING ROD, M10	
61	021100202	2	ナット、2M10	NUT, 2 M10	

From the library of: Diamond Needle Corp

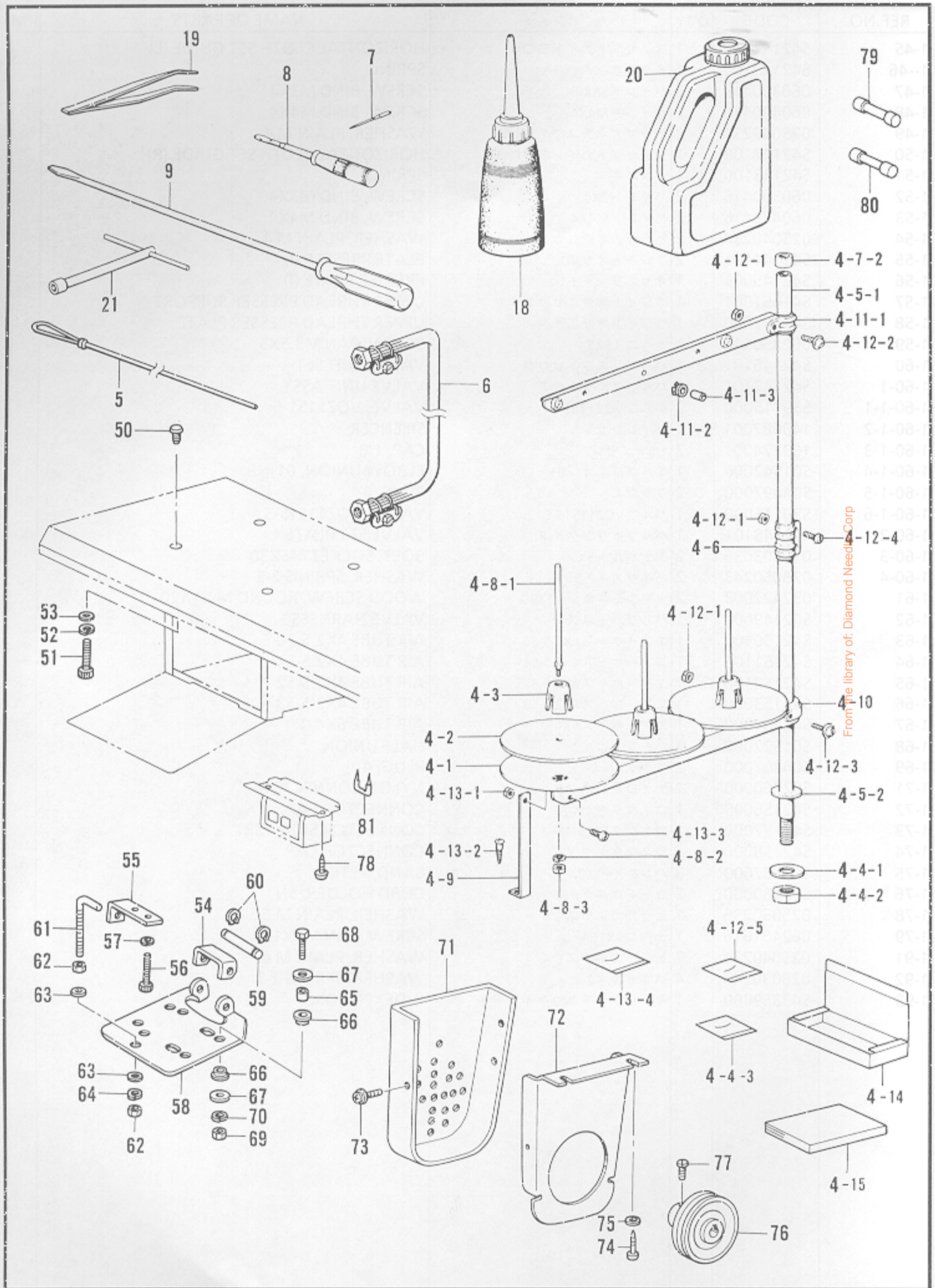

From the library of: Diamond Needle Corp

Z. 付属品関係 / Accessories / Zubehör / Accessoires / Accesorios

REF.NO.	CODE	Q'TY	ヒンメイ	NAME OF PARTS	RM
4	S02766109	1	イトタテダイクミ3D	COTTON STAND ASSY, 3D	
4-1	150180001	3	ウケザラ	SPOOL STAND BASE	
4-2	150182000	3	スプールのマット	SPOOL MAT	
4-3	126863001	3	スプールのクッション	SPOOL CUSHION	
4-4	S02775001	1	パイプネジセットA	PIPE SCREW SET, A	
4-4-1	150206002	1	ヒラザガネ16	WASHER, PLAIN 16	
4-4-2	S38648001	1	6カクナツU5/8	NUT, U5/8-28	
4-4-3	S30302000	1	ポリフクロS	PE. BAG, 70X70	
4-5	156112003	1	コラムパイプD	COLUMN PIPE, D	
4-5-1	150207001	1	コラムパイプネジツキ	COLUMN PIPE WITH SCREW	
4-5-2	150206000	1	ヒラザガネ16	WASHER, PLAIN 16	
4-6	150173003	1	コラムジョイント	COLUMN JOINT	
4-7	S40640001	1	コラムパイプキャップツキ	COLUMN PIPE WITH CAP	
4-7-1	150174000	1	コラムキャップ	COLUMN CAP	
4-8	S21798001	3	スプールのネジセット	SPOOL SCREW SET	
4-8-1	150179002	3	スプールのジクB	SPOOL SHAFT, B	
4-8-2	028050246	3	バネザガネ2-5	WASHER, SPRING 2-5	
4-8-3	021500106	3	1シユナツト5	NUT, 1 M5	
4-9	150188009	1	スプールのホルダーササエA	SPOOL HOLDER SUPPORT, A	
4-10	S02779009	1	スプールのホルダー3	SPOOL HOLDER, 3	
4-11	S02788009	1	スレッドハンガークミ3	THREAD HANGER ASSY, 3	
4-11-1	S02789009	1	スレッドハンガー3	THREAD HANGER, 3	
4-11-2	150183000	3	イトカケハンガーダイ	THREAD HANGER BASE	
4-11-3	142990001	3	スレッドブツシュ	THREAD BUSH	
4-12	S40641001	1	スプールのジクネジセットA	SPOOL SCREW SET, A	
4-12-1	021500106	4	1シユナツト5	NUT, 1 M5	
4-12-2	S37038001	1	ナベコヒラザ5X14	SCREW, PAN (P WASHER) M5X14	
4-12-3	S37037001	1	ナベコヒラザ5X32	SCREW, PAN (P WASHER) M5X32	
4-12-4	062501406	2	ナベコ5X14	SCREW, PAN M5X14	
4-12-5	S30302000	1	ポリフクロS	PE. BAG, 70X70	
4-13	S40644001	1	ホルダーツギテネジセット	HOLDER JOINT SCREW SET	
4-13-1	021500106	1	1シユナツト5	NUT, 1 M5	
4-13-2	031452206	1	マルモク45X22	WOOD SCREW, ROUND M4.5X22	
4-13-3	062501006	1	ナベコ5X10	SCREW, PAN M5X10	
4-13-4	S30302000	1	ポリフクロS	PE. BAG, 70X70	
4-14	S02816000	1	ソトハコ	CARTON	
4-15	192737132	1	トリアツカイセツメイシヨ	INSTRUCTION MANUAL	
5	S34915000	1	イトトオシ	THREADER	
6	149796001	1	ゴムホースカナグツキ	AIR TUBE WITH CONNECTOR	
7	S35133118	1	ミシンハリDOX558クミ	NEEDLE ASSY, DOX558 (#18)	
8	118837001	1	ネジマワシ3.4X70	SCREW DRIVER, 3.4X70	
9	101572101	1	ネジマワシ5.5X190	SCREW DRIVER, 5.5X190	
18	114483002	1	ポリオイラークミ	OILER ASSY	
19	117466000	1	ピンセット	PINCETTE	
20	154702101	1	オイルタンク	OIL TANK	
21	140342001	1	ソケットレンチクミ	SOCKET WRENCH ASSY	
50	S43729000	8	-----	NUT I-M6X20	
51	018065022	4	-----	BOLT, SOCKET M6X50	
52	028060242	4	-----	WASHER, SPRING 2-6	
53	122257001	4	-----	WASHER	
54	S43715001	1	-----	MOTOR PLATE	
55	S43716001	1	-----	BOLT INDICATION PLATE	
56	018065022	4	-----	BOLT, SOCKET M6X50	
57	028060242	4	-----	WASHER, SPRING 2-6	
58	152861101	1	-----	MOTOR BASE PLATE	
59	152862001	1	-----	MOTOR BASE PLATE SHAFT	
60	048100142	2	-----	RETAINING RING, C10	
61	152865201	1	-----	BELT ADJUSTING ROD, M10	
62	021100202	2	-----	NUT, 2 M10	

From the library of: Diamond Needle Corp

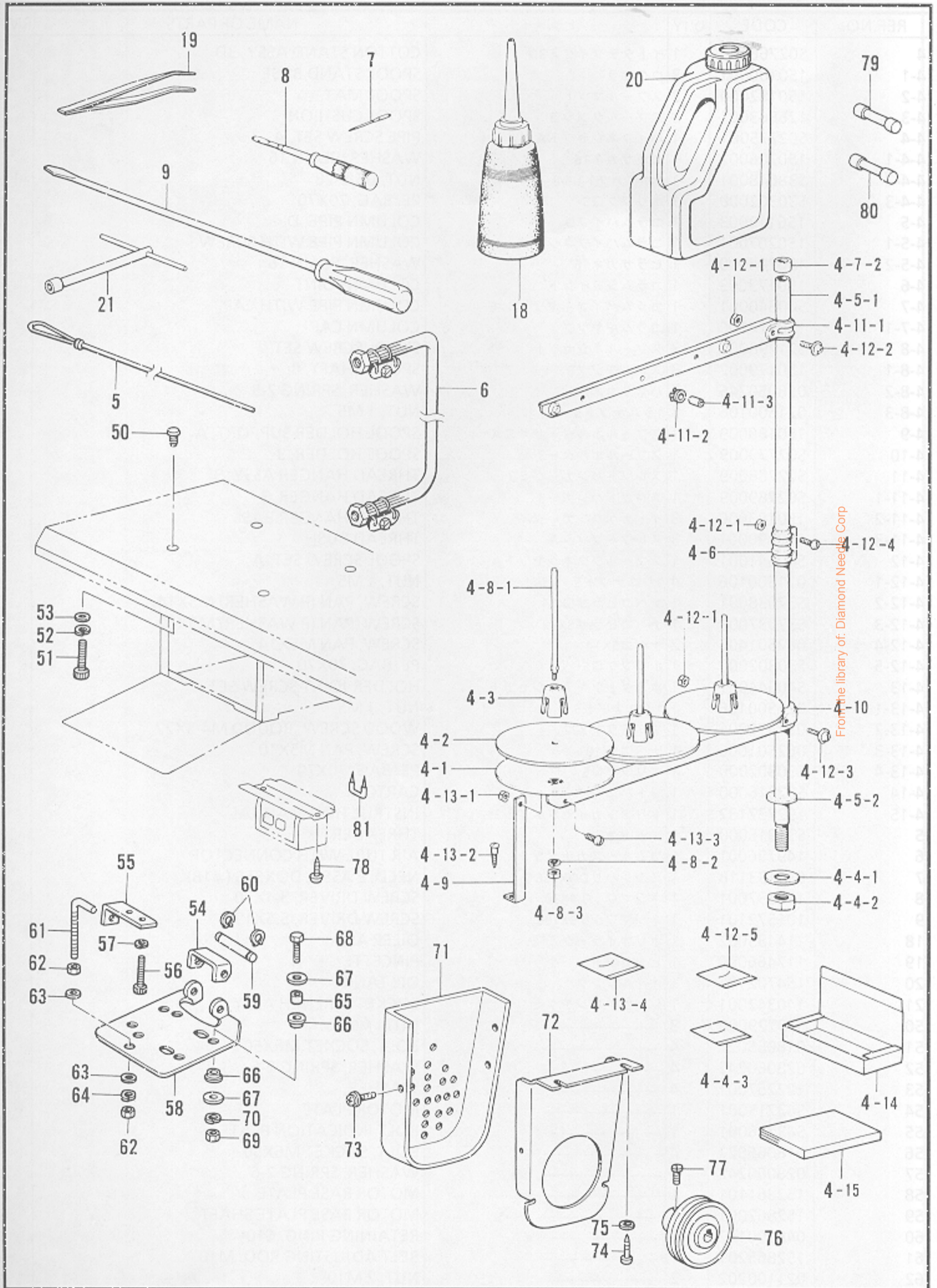

From the library of: Diamond Needle Corp

Z. 付属品関係 / Accessories / Zubehör / Accessoires / Accesorios

REF.NO.	CODE	Q'TY	ヒンメイ	NAME OF PARTS	RM
63	025100132	2	-----	WASHER, PLAIN S 10	
64	028100242	1	-----	WASHER, SPRING 2-10	
65	152863001	4	-----	CUSHION COLLAR	
66	152864000	8	-----	CUSHION	
67	025800332	8	-----	WASHER, PLAIN L 7.14	
68	017062503	4	-----	BOLT, M6X25	
69	021060106	4	-----	NUT, 1 M6	
70	028060242	4	-----	WASHER, SPRING 2-6	
71	S43714000	1	-----	MOTOR COVER, 981	
72	S43713001	1	-----	MOTOR REAR COVER SUPPORT	
73	052400806	3	-----	SCREW, PAN (S/P WASHER) M4X8	
74	101118001	2	-----	WOOD SCREW, ROUND M4.5X20	
75	025050232	2	-----	WASHER, PLAIN M 5	
76	S38041000	1	-----	MOTOR PULLEY	
77	105073001	1	-----	SET SCREW, SOCKET SM5.95	
78	032461606	2	-----	WOOD SCREW, ROUND M4.5X16	
79	S08030000	1	-----	FUSE, 5A FB	
80	153242000	1	-----	FUSE, 6A	
81	200190001	4	-----	STAPLE	
				MOVABLE KNIFE (L3)(R)	
				MOVABLE KNIFE (L3)(R)	
				THREAD HANDLER L3	
				MOVABLE KNIFE DRIVING CAM (L3)	
				EXCHANGE PARTS SET (L4)	
				PLATE (R) ASSY	
				CLOTH PRESSER PLATE (J)(R4) SET	
				NEEDLE PLATE (L4)(R)	
				CLOTH PRESSER (R-1)(L4)	
				MOVABLE KNIFE (L4)(R)	
				MOVABLE KNIFE (L4)(R)	
				THREAD HANDLER L4	
				MOVABLE KNIFE DRIVING CAM (L4)	
				CLOTH PRESSER PLATE (J)(R) ASSY	
				OPENING SLIDE BLOCK	
				SCREW, BIND M2X4	
				SCREW, FLAT M3X6	
				BENDING WASHER, M3	
				CLAMP SUPPORT PIN	
				NUT, 3 M3	
				CLAMP SHAFT HOLDER	
				SCREW, PAN M4X10	
				CLAMP FULCRUM SHAFT	
				RETAINING RING JCS	
				CLAMP LEVER (R)	
				BOLT, SOCKET M5X12	
				CLAMP ARM (R)	
				SET SCREW, SOCKET (CP) M4X5	
				ROTH GUIDE (R)	
				SCREW, BIND M3.5X6	
				SHOULDER SCREW, M4	
				NUT, 2 M4	
				WASHER, WAVE	
				KNIFE SUPPORT WASHER	
				SCREW, FLAT M3.5	
				THREAD TRIMMER ARM (LAYER) ASSY	
				SHOULDER SCREW	
				NUT, 2 M4	
				LINK FULCRUM PLATE	
				SCREW, PAN M4X5	
				SPRING (L)	
				SPRING (R)	
				SCREW, PAN M2.5X4	
				THREAD TRIMMER ARM BUSH	
				SCREW, PAN M2.5X6	
				THREAD CUTTER LEVER ARM (B)	
				SCREW 4X10	
				NEEDLE PIN 4X8	
				PRESSER PLATE (U)	
				SCREW, FLAT M4X10	
				SCREW, M2.38	

From the library of: Diamond Needle Corp

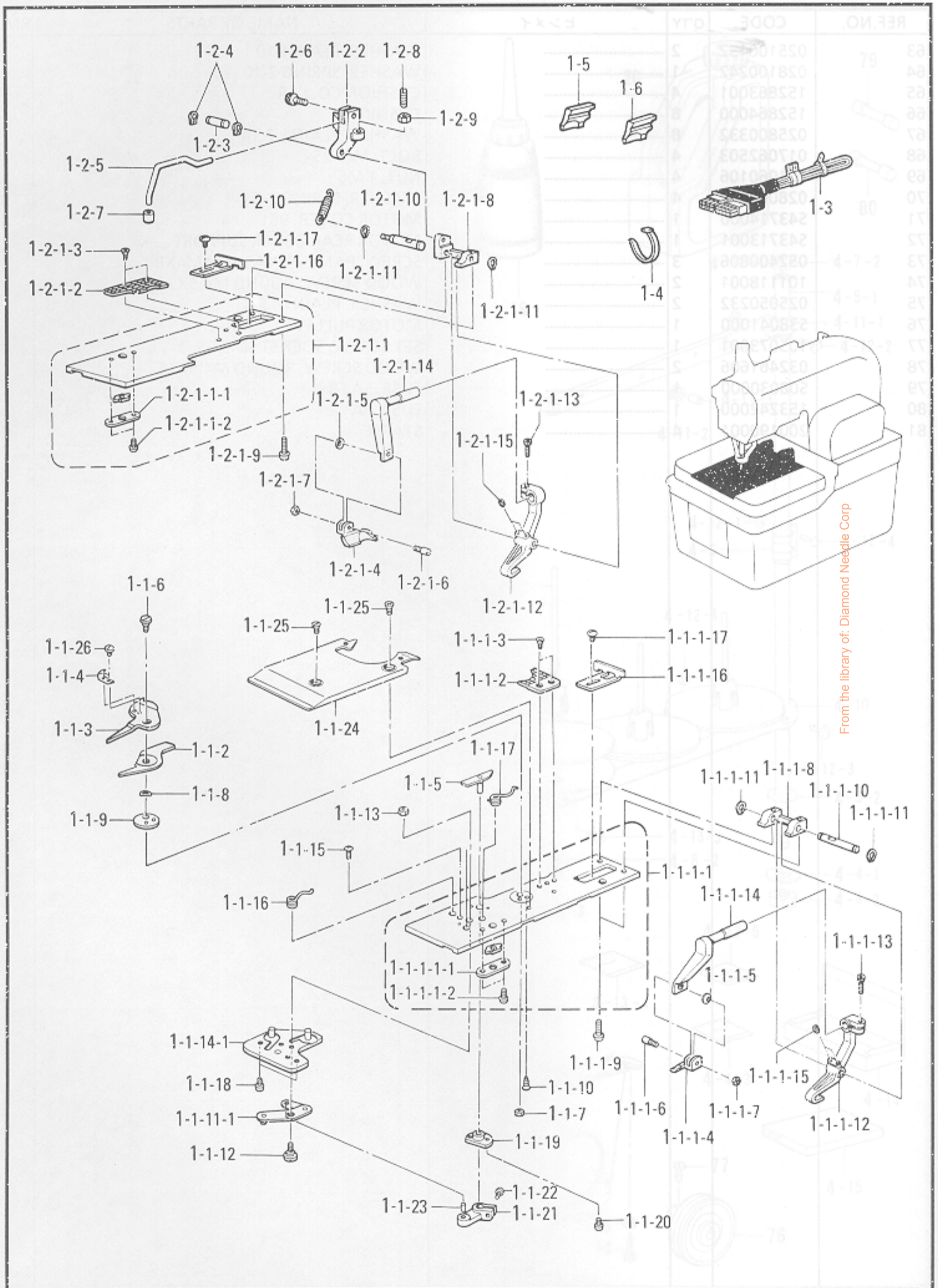

a1. 付属装置セット / Attachment set / Anbausatz / Jeu d'accessoires / Juego de fijación

REF.NO.	CODE	Q'TY	ヒンメイ	NAME OF PARTS	RM
<b>&lt;L1 14-18mm&gt;</b>					
1	S44238001	1	クミカエブヒンセット(L1)	EXCHANGE PARTS SET (L1)	
1-1	S38576301	1	L1プレートRクミ	(L1) PLATE (R) ASSY	
1-1-1	S37756401	1	オサエプレートJR1ソウクミ	CLOTH PRESSER PLATE (J)(R1) SET	
1-1-1-2	S37644101	1	ハリイタL1R	NEEDLE PLATE (L1)(R)	
1-1-1-4	S37754001	1	ヌノオサエR-JL1	CLOTH PRESSER (R-J)(L1)	
1-1-2	S37673101	1	イドウハL1R	MOVABLE KNIFE (L1)(R)	
1-1-3	S37669101	1	イドウハL1L	MOVABLE KNIFE (L1)(L)	
1-1-4	S37665000	1	イトサバキL1	THREAD HANDLER L1	
1-1-5	S37661001	1	イドウハクドウカムL1	MOVABLE KNIFE DRIVING CAM (L1)	
<b>&lt;L2 18-22mm&gt;</b>					
1	S44239001	1	クミカエブヒンセット(L2)	EXCHANGE PARTS SET (L2)	
1-1	S38578301	1	L2プレートRクミ	(L2) PLATE (R) ASSY	
1-1-1	S37727401	1	オサエプレートJR2ソウクミ	CLOTH PRESSER PLATE (J)(R2) SET	
1-1-1-2	S37646101	1	ハリイタL2R	NEEDLE PLATE (L2)(R)	
1-1-1-4	S37690001	1	ヌノオサエR-JL2	CLOTH PRESSER (R-J)(L2)	
1-1-2	S37674101	1	イドウハL2R	MOVABLE KNIFE (L2)(R)	
1-1-3	S37670101	1	イドウハL2L	MOVABLE KNIFE (L2)(L)	
1-1-4	S37666000	1	イトサバキL2	THREAD HANDLER L2	
1-1-5	S37662001	1	イドウハクドウカムL2	MOVABLE KNIFE DRIVING CAM (L2)	
<b>&lt;L3 22-26mm&gt;</b>					
1	S44240001	1	クミカエブヒンセット(L3)	EXCHANGE PARTS SET (L3)	
1-1	S38580301	1	L3プレートRクミ	(L3) PLATE (R) ASSY	
1-1-1	S37733401	1	オサエプレートJR3ソウクミ	CLOTH PRESSER PLATE (J)(R3) SET	
1-1-1-2	S37648101	1	ハリイタL3R	NEEDLE PLATE (L3)(R)	
1-1-1-4	S37692001	1	ヌノオサエR-JL3	CLOTH PRESSER (R-J)(L3)	
1-1-2	S37675101	1	イドウハL3R	MOVABLE KNIFE (L3)(R)	
1-1-3	S37671101	1	イドウハL3L	MOVABLE KNIFE (L3)(L)	
1-1-4	S37667000	1	イトサバキL3	THREAD HANDLER L3	
1-1-5	S37663001	1	イドウハクドウカムL3	MOVABLE KNIFE DRIVING CAM (L3)	
<b>&lt;L4 26-30mm&gt;</b>					
1	S44271001	1	クミカエブヒンセット(L4)	EXCHANGE PARTS SET (L4)	
1-1	S38582301	1	L4プレートRクミ	(L4) PLATE (R) ASSY	
1-1-1	S37757401	1	オサエプレートJR4ソウクミ	CLOTH PRESSER PLATE (J)(R4) SET	
1-1-1-2	S37650101	1	ハリイタL4R	NEEDLE PLATE (L4)(R)	
1-1-1-4	S37758001	1	ヌノオサエR-JL4	CLOTH PRESSER (R-J)(L4)	
1-1-2	S37676101	1	イドウハL4R	MOVABLE KNIFE (L4)(R)	
1-1-3	S37672101	1	イドウハL4L	MOVABLE KNIFE (L4)(L)	
1-1-4	S37668000	1	イトサバキL4	THREAD HANDLER L4	
1-1-5	S37664001	1	イドウハクドウカムL4	MOVABLE KNIFE DRIVING CAM (L4)	
1-1-1-1	S37729101	1	オサエプレートJRクミ	CLOTH PRESSER PLATE (J)(R) ASSY	
1-1-1-1-1	S35315001	1	ヒラキカクコマ	OPENING SLIDE BLOCK	
1-1-1-1-2	060020416	2	バインドM2X4	SCREW, BIND M2X4	
1-1-1-3	S06696004	2	サラコネジ3X6	SCREW, FLAT M3X6	
1-1-1-5	S35236000	1	マゲザガネ3.2	BENDING WASHER, M3.2	
1-1-1-6	S35235001	1	クランプササエピン	CLAMP SUPPORT PIN	
1-1-1-7	021300302	1	3シユナツト3	NUT, 3 M3	
1-1-1-8	S35238001	1	クランプジクウケ	CLAMP SHAFT HOLDER	
1-1-1-9	062401016	2	ナベコ4X10	SCREW, PAN M4X10	
1-1-1-10	S35237001	1	クランプシテンジク	CLAMP FULCRUM SHAFT	
1-1-1-11	048050142	2	トメワジクヨウC5	RETAINING RING, C5	
1-1-1-12	S35234201	1	クランプレバーR	CLAMP LEVER (R)	
1-1-1-13	018501236	1	アナボルト5X12	BOLT, SOCKET M5X12	
1-1-1-14	S37695001	1	クランプアームR-J	CLAMP ARM (R-J)	
1-1-1-15	014400532	2	アナクボミ4X5	SET SCREW, SOCKET (CP) M4X5	
1-1-1-16	S35347100	1	ヌノガイドR	CLOTH GUIDE (R)	
1-1-1-17	060350616	1	バインド3.5X6	SCREW, BIND M3.5X6	
1-1-6	S37660101	1	ダンネジM4	SHOULDER SCREW, M4	
1-1-7	021400202	1	2シユナツト4	NUT, 2 M4	
1-1-8	S37654000	1	ナミザガネ	WASHER, WAVE	
1-1-9	S37655101	1	メスササエザガネ	KNIFE SUPPORT WASHER	
1-1-10	141542001	2	サラネジ3.18	SCREW, FLAT M3.18	
1-1-11-1	S37656001	1	イトキリリンクレバーJクミ	THREAD TRIMMER LINK LEVER (J) ASSY	
1-1-12	S34881001	1	ダンネジM4	SHOULDER SCREW, M4	
1-1-13	021400202	1	2シユナツト4	NUT, 2 M4	
1-1-14-1	S37820001	1	リンクシテンプレートクミ	LINK FULCRUM PLATE ASSY	
1-1-15	062400616	2	ナベコM4X6	SCREW, PAN M4X6	
1-1-16	S37652001	1	モドシパネルL	SPRING (L)	
1-1-17	S37653001	1	モドシパネルR	SPRING (R)	
1-1-18	062300416	2	ナベコM3X4	SCREW, PAN M3X4	
1-1-19	S34906000	1	イトキリウデメタル	THREAD TRIMMER ARM BUSH	
1-1-20	062260612	2	ナベコ2.6X6	SCREW, PAN M2.6X6	
1-1-21	S37659001	1	イトキリレバーウデB	THREAD CUTTER LEVER ARM (B)	
1-1-22	S21716001	1	ボタンヘッドネジ4X10	SCREW 4X10	
1-1-23	S37858000	1	ニードルピン4X8	NEEDLE PIN 4X8	
1-1-24	S37700001	1	オサエプレートU	PRESSER PLATE (U)	
1-1-25	004401003	2	+サラネジ4X10	SCREW, FLAT M4X10	
1-1-26	153787001	2	シメネジ2.38	SCREW, M2.38	

From the library of: Diamond Needle Corp



a1. 付属装置セット / Attachment set / Anbausatz / Jeu d'accessoires / Juego de fijación

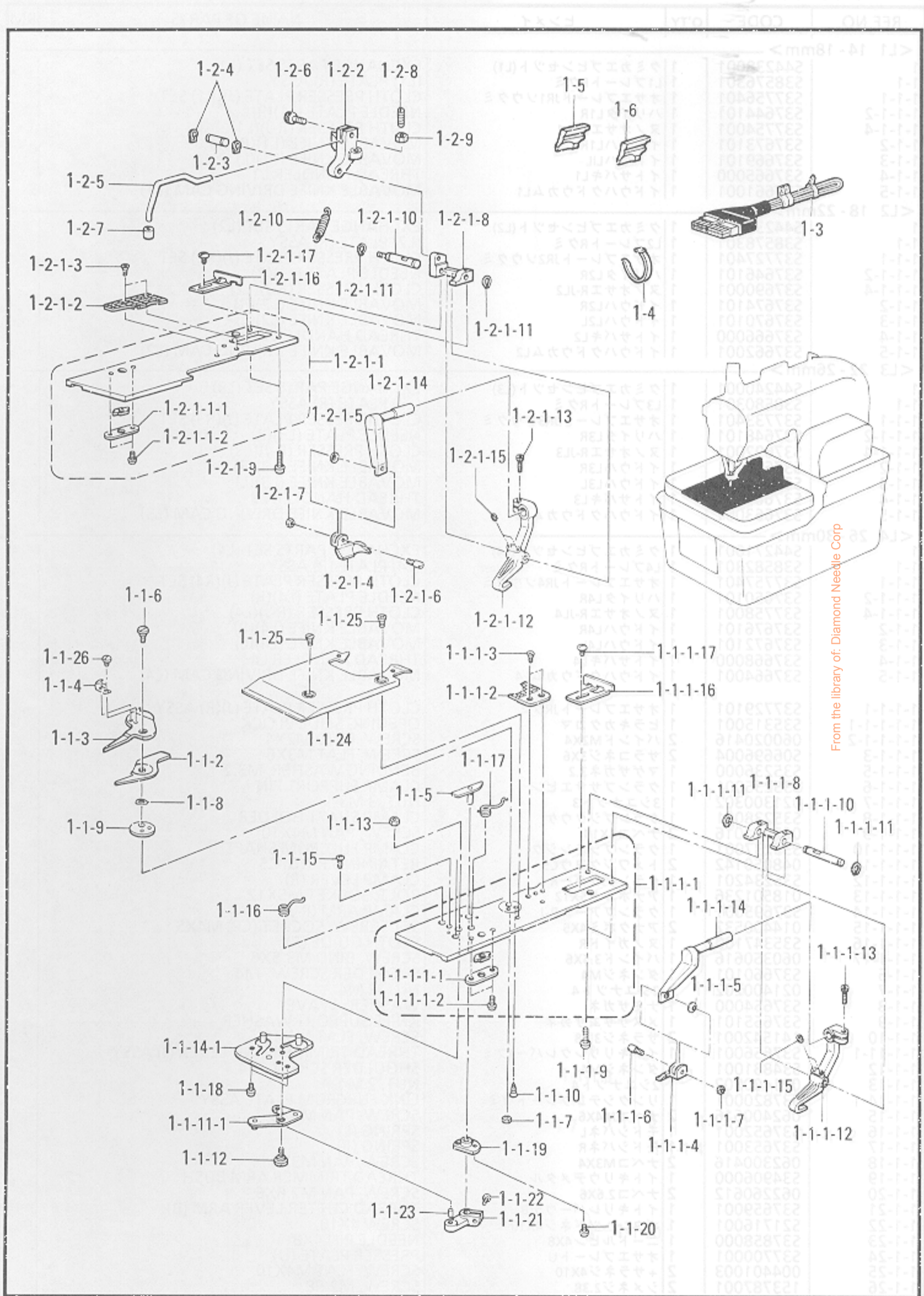

From the library of: Diamond Needle Corp

a1. 付属装置セット / Attachment set / Anbausatz / Jeu d'accessoires / Juego de fijación

REF.NO.	CODE	Q'TY	ヒンメイ	NAME OF PARTS	RM
<L1 14 - 18mm>					
1-2	S38577201	1	L1プレートLクミ	(L1) PLATE (L) ASSY	
1-2-1	S37731301	1	オサエプレートJL1ソウクミ	CLOTH PRESSER PLATE (J)(L1) SET	
1-2-1-2	S37643201	1	ハリイタL1L	NEEDLE PLATE (L1)(L)	
1-2-1-4	S37755001	1	ヌノオサエL-JL1	CLOTH PRESSER (L-J)(L1)	
1-3	S43337000	1	981シヨウハーネスL1	HARNES 981(L1)	
1-5	S37702001	1	ハンマーS12	HAMMER (S12)	
1-6	S37704001	1	ハンマーS16	HAMMER (S16)	
<L2 18 - 22mm>					
1-2	S38579201	1	L2プレートLクミ	(L2) PLATE (L) ASSY	
1-2-1	S37728301	1	オサエプレートJL2ソウクミ	CLOTH PRESSER PLATE (J)(L2) SET	
1-2-1-2	S37645201	1	ハリイタL2L	NEEDLE PLATE (L2)(L)	
1-2-1-4	S37689001	1	ヌノオサエL-JL2	CLOTH PRESSER (L-J)(L2)	
1-3	S43338000	1	981シヨウハーネスL2	HARNES 981(L2)	
1-5	S37704001	1	ハンマーS16	HAMMER (S16)	
1-6	S37706001	1	ハンマーS20	HAMMER (S20)	
<L3 22 - 26mm>					
1-2	S38581201	1	L3プレートLクミ	(L3) PLATE (L) ASSY	
1-2-1	S37735301	1	オサエプレートJL3ソウクミ	CLOTH PRESSER PLATE (J)(L3) SET	
1-2-1-2	S37647101	1	ハリイタL3L	NEEDLE PLATE (L3)(L)	
1-2-1-4	S37691001	1	ヌノオサエL-JL3	CLOTH PRESSER (L-J)(L3)	
1-3	S43339000	1	981シヨウハーネスL3	HARNES 981(L3)	
1-5	S37706001	1	ハンマーS20	HAMMER (S20)	
1-6	S37708001	1	ハンマーS24	HAMMER (S24)	
<L4 26 - 30mm>					
1-2	S38583201	1	L4プレートLクミ	(L4) PLATE (L) ASSY	
1-2-1	S37732301	1	オサエプレートJL4ソウクミ	CLOTH PRESSER PLATE (J)(L4) SET	
1-2-1-2	S37649101	1	ハリイタL4L	NEEDLE PLATE (L4)(L)	
1-2-1-4	S37759001	1	ヌノオサエL-JL4	CLOTH PRESSER (L-J)(L4)	
1-3	S43340000	1	981シヨウハーネスL4	HARNES (L4)	
1-5	S37708001	1	ハンマーS24	HAMMER (S24)	
1-6	S42053001	1	ハンマーS28	HAMMER (S28)	
1-2-1-1	S37730001	1	オサエプレートJLクミ	CLOTH PRESSER PLATE (J)(L) ASSY	
1-2-1-1-1	S35316001	1	カクコマササエイタ	SLIDE BLOCK SUPPORT PLATE	
1-2-1-1-2	060020416	2	バインドM2X4	SCREW, BIND M2X4	
1-2-1-3	S06696004	2	サラコネジ3X6	SCREW, FLAT M3X6	
1-2-1-5	S35236000	1	マゲザガネ3.2	BENDING WASHER, M3.2	
1-2-1-6	S35235001	1	クランプササエピン	CLAMP SUPPORT PIN	
1-2-1-7	021300302	1	3シユナツト3	NUT, 3 M3	
1-2-1-8	S37712001	1	クランプジクウケ	CLAMP SHAFT HOLDER	
1-2-1-9	062401016	2	ナベコ4X10	SCREW, PAN M4X10	
1-2-1-10	S37711001	1	クランプシテンジク	CLAMP FULCRUM SHAFT	
1-2-1-11	048050142	2	トメワジクヨウC5	RETAINING RING, C5	
1-2-1-12	S35233201	1	クランプレバーL	CLAMP LEVER (L)	
1-2-1-13	018501236	1	アナボルト5X12	BOLT, SOCKET M5X12	
1-2-1-14	S37694001	1	クランプアームL-J	CLAMP ARM (L-J)	
1-2-1-15	014400532	2	アナクボミ4X5	SET SCREW, SOCKET (CP) M4X5	
1-2-1-16	S35348100	1	ヌノガイドL	CLOTH GUIDE (L)	
1-2-1-17	060350616	1	バインド3.5X6	SCREW, BIND M3.5X6	
1-2-2	S37714001	1	ホジヨオサエシテンダイ	SUB PRESSER FULCRUM BRACKET	
1-2-3	S37713001	1	ホジヨオサエシテンジク	SUB PRESSER FULCRUM SHAFT	
1-2-4	048050142	2	トメワジクヨウC5	RETAINING RING, C5	
1-2-5	S37718000	1	ホジヨオサエウデ	SUB PRESSER ARM	
1-2-6	018401032	1	アナボルト4X10	BOLT 4X10	
1-2-7	S05356000	1	ボタンオサエA	BUTTON PRESSER (A)	
1-2-8	S08808001	1	ストップネジ	STOPPER SCREW	
1-2-9	021660102	1	ナツト1シユ3.18	NUT, 1 SM3.18	
1-2-10	S37753001	1	ホジヨオサエモドシバネ	SUB PRESSER SPRING	
1-4	S04557000	1	バンタイPLTIM	BAND PLTIM	

From the library of: Diamond Needle Corp

118-981-940

118-981-940

a2. 付属装置セット / Attachment set / Anbausatz / Jeu d'accessoires / Juego de fijación

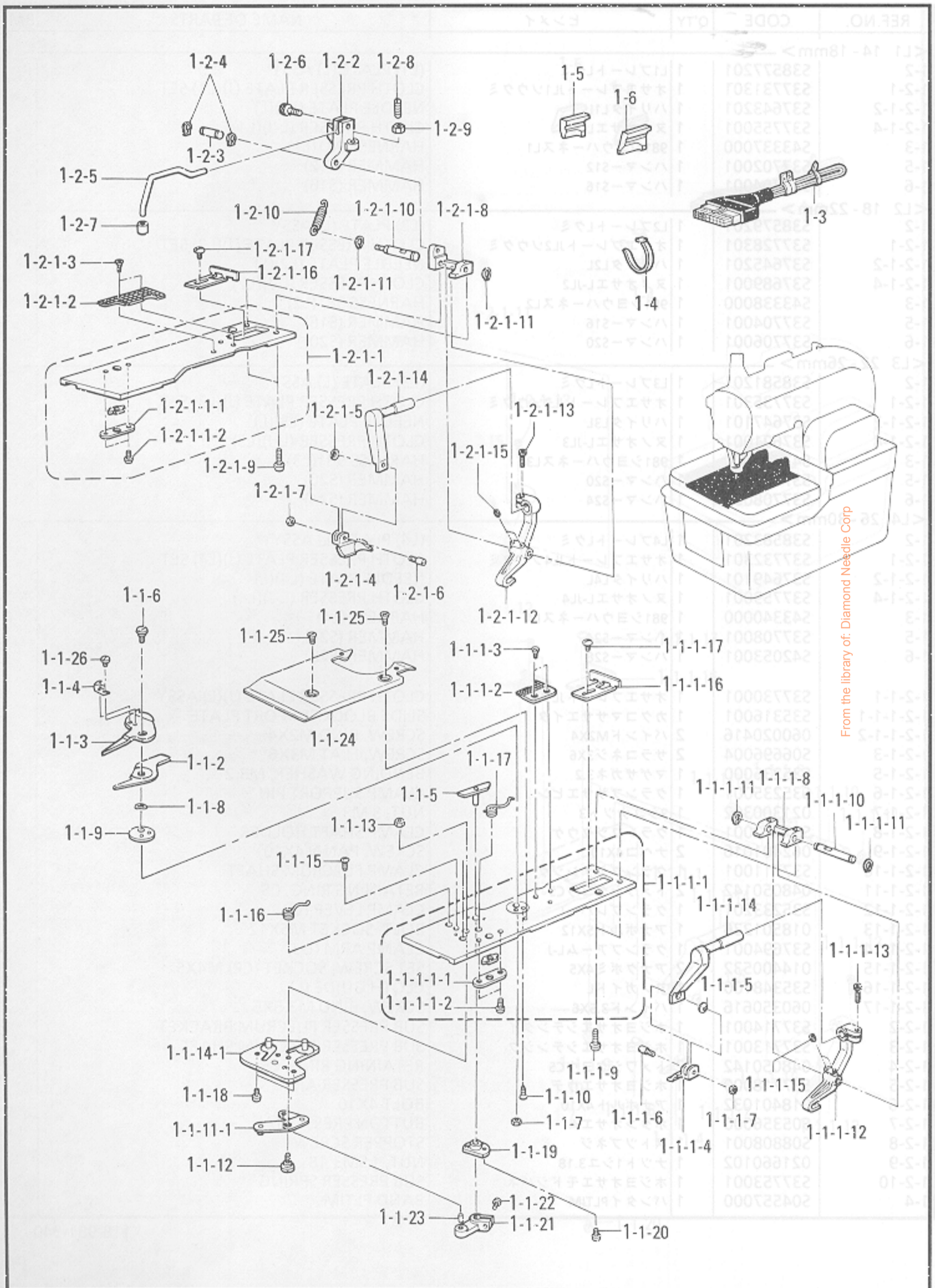

From the library of: Diamond Needle Corp

a2. 付属装置セット / Attachment set / Anbausatz / Jeu d'accessoires / Juego de fijación

REF.NO.	CODE	Q'TY	ヒンメイ	NAME OF PARTS	RM
<b>&lt;L5 28-32mm&gt;</b>					
1	S44272001	1	クミカエブヒンセット(L5)	EXCHANGE PARTS SET (L5)	
1-1	S41470101	1	L5プレートRクミ	(L5) PLATE (R) ASSY	
1-1-1	S40830101	1	オサエプレートJR5ソウクミ	CLOTH PRESSER PLATE (J)(R5) SET	
1-1-1-2	S40822001	1	ハリイタL5R	NEEDLE PLATE (L5)(R)	
1-1-1-4	S41483001	1	ヌノオサエR-JL5	CLOTH PRESSER (R-J)(L5)	
1-1-2	S37674101	1	イドウハL2R	MOVABLE KNIFE (L2)(R)	
1-1-3	S37670101	1	イドウハL2L	MOVABLE KNIFE (L2)(L)	
1-1-4	S37666000	1	イトサバキL2	THREAD HANDLER L2	
1-1-5	S37662001	1	イドウハクドウカムL2	MOVABLE KNIFE DRIVING CAM (L2)	
<b>&lt;L6 32-36mm&gt;</b>					
1	S44273001	1	クミカエブヒンセット(L6)	EXCHANGE PARTS SET (L6)	
1-1	S41472101	1	L6プレートRクミ	(L6) PLATE (R) ASSY	
1-1-1	S41489101	1	オサエプレートJR6ソウクミ	CLOTH PRESSER PLATE (J)(R6) SET	
1-1-1-2	S41479001	1	ハリイタL6R	NEEDLE PLATE (L6)(R)	
1-1-1-4	S41485001	1	ヌノオサエR-JL6	CLOTH PRESSER (R-J)(L6)	
1-1-2	S37675101	1	イドウハL3R	MOVABLE KNIFE (L3)(R)	
1-1-3	S37671101	1	イドウハL3L	MOVABLE KNIFE (L3)(L)	
1-1-4	S37667000	1	イトサバキL3	THREAD HANDLER L3	
1-1-5	S37663001	1	イドウハクドウカムL3	MOVABLE KNIFE DRIVING CAM (L3)	
<b>&lt;L7 36-40mm&gt;</b>					
1	S44274001	1	クミカエブヒンセット(L7)	EXCHANGE PARTS SET (L7)	
1-1	S41474101	1	L7プレートRクミ	(L7) PLATE (R) ASSY	
1-1-1	S41491101	1	オサエプレートJR7ソウクミ	CLOTH PRESSER PLATE (J)(R7) SET	
1-1-1-2	S41481001	1	ハリイタL7R	NEEDLE PLATE (L7)(R)	
1-1-1-4	S41487001	1	ヌノオサエR-JL7	CLOTH PRESSER (R-J)(L7)	
1-1-2	S37676101	1	イドウハL4R	MOVABLE KNIFE (L4)(R)	
1-1-3	S37672101	1	イドウハL4L	MOVABLE KNIFE (L4)(L)	
1-1-4	S37668000	1	イトサバキL4	THREAD HANDLER L3	
1-1-5	S37664001	1	イドウハクドウカムL4	MOVABLE KNIFE DRIVING CAM (L4)	
1-1-1-1	S40828001	1	オサエプレートJRクミ B	CLOTH PRESSER PLATE (J)(R) ASSY, B	
1-1-1-1-1	S35315001	1	ヒラキカクコマ	OPENING SLIDE BLOCK	
1-1-1-1-2	060020416	2	バインドM2X4	SCREW, BIND M2X4	
1-1-1-3	S06696004	2	サラコネジ3X6	SCREW, FLAT M3X6	
1-1-1-5	S35236000	1	マゲザガネ3.2	BENDING WASHER, M3.2	
1-1-1-6	S35235001	1	クランプササエピン	CLAMP SUPPORT PIN	
1-1-1-7	021300302	1	3シユナツト3	NUT, 3 M3	
1-1-1-8	S35238001	1	クランプジクウケ	CLAMP SHAFT HOLDER	
1-1-1-9	062401016	2	ナベコ4X10	SCREW, PAN M4X10	
1-1-1-10	S35237001	1	クランプシテンジク	CLAMP FULCRUM SHAFT	
1-1-1-11	048050142	2	トメワジクヨウC5	RETAINING RING, C5	
1-1-1-12	S35234201	1	クランプレバーR	CLAMP LEVER (R)	
1-1-1-13	018501236	1	アナボルト5X12	BOLT, SOCKET M5X12	
1-1-1-14	S40826001	1	クランプアームR-J-B	CLAMP ARM (R-J-B)	
1-1-1-15	014400532	2	アナクボミ4X5	SET SCREW, SOCKET (CP) M4X5	
1-1-1-16	S35347000	1	ヌノガイドR	CLOTH GUIDE (R)	
1-1-1-17	060350616	1	バインド3.5X6	SCREW, BIND M3.5X6	
1-1-6	S37660101	1	ダンネジM4	SHOULDER SCREW, M4	
1-1-7	021400202	1	2シユナツト4	NUT, 2 M4	
1-1-8	S37654000	1	ナミザガネ	WASHER, WAVE	
1-1-9	S37655101	1	メスササエザガネ	KNIFE SUPPORT WASHER	
1-1-10	141542001	2	サラネジ3.18	SCREW, FLAT M3.18	
1-1-11-1	S37656001	1	イトキリリンクレバーJクミ	THREAD TRIMMER LINK LEVER (J) ASSY	
1-1-12	S34881001	1	ダンネジM4	SHOULDER SCREW, M4	
1-1-13	021400202	1	2シユナツト4	NUT, 2 M4	
1-1-14-1	S37820001	1	リンクシテンプレートクミ	LINK FULCRUM PLATE ASSY	
1-1-15	062400616	2	ナベコM4X6	SCREW, PAN M4X6	
1-1-16	S37652001	1	モドシバネL	SPRING (L)	
1-1-17	S37653001	1	モドシバネR	SPRING (R)	
1-1-18	062300416	2	ナベコM3X4	SCREW, PAN M3X4	
1-1-19	S34906000	1	イトキリウデメタル	THREAD TRIMMER ARM BUSH	
1-1-20	062260612	2	ナベコ2.6X6	SCREW, PAN M2.6X6	
1-1-21	S37659001	1	イトキリレバーウデB	THREAD CUTTER LEVER ARM (B)	
1-1-22	S21716001	1	ボタンヘッドネジ4X10	SCREW 4X10	
1-1-23	S37858000	1	ニードルピン4X8	NEEDLE PIN 4X8	
1-1-24	S37700001	1	オサエプレートU	PRESSER PLATE (U)	
1-1-25	004401003	2	+サラネジ4X10	SCREW, FLAT M4X10	
1-1-26	153787001	2	シメネジ2.38	SCREW, M2.38	

From the library of: Diamond Needle Corp

a2. 付属装置セット / Attachment set / Anbausatz / Jeu d'accessoires / Juego de fijación

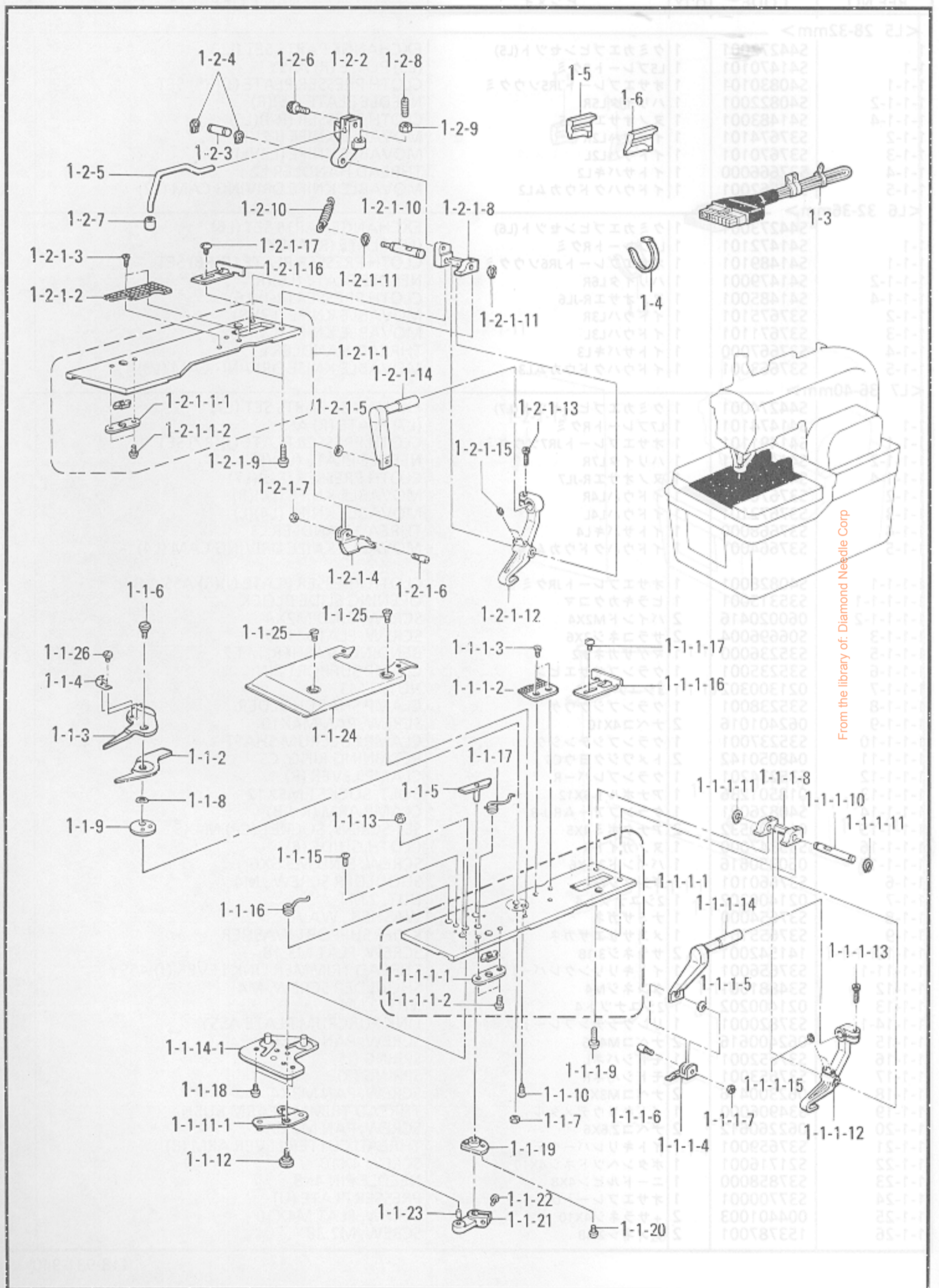

From the library of: Diamond Needle Corp

a2. 付属装置セット / Attachment set / Anbausatz / Jeu d'accessoires / Juego de fijación

REF.NO.	CODE	Q'TY	ヒンメイ	NAME OF PARTS	RM
<b>&lt;L5 28-32mm&gt;</b>					
1-2	S41471101	1	L5プレートLクミ	(L5) PLATE (L) ASSY	
1-2-1	S40831101	1	オサエプレートJL5ソウクミ	CLOTH PRESSER PLATE (J)(L5) SET	
1-2-1-2	S40823001	1	ハリイタL5L	NEEDLE PLATE (L5)(L)	
1-2-1-4	S41484001	1	ヌノオサエL-JL5	CLOTH PRESSER (L-J)(L5)	
1-3	S43341000	1	981シヨウハーネスL5	HARNES 981(L5)	
1-5	S37197001	1	ハンマー26	HAMMER (26)	
1-6	S37199001	1	ハンマー30	HAMMER (30)	
<b>&lt;L6 32-36mm&gt;</b>					
1-2	S41473101	1	L6プレートLクミ	(L6) PLATE (L) ASSY	
1-2-1	S41490101	1	オサエプレートJL6ソウクミ	CLOTH PRESSER PLATE (J)(L6) SET	
1-2-1-2	S41480001	1	ハリイタL6L	NEEDLE PLATE (L6)(L)	
1-2-1-4	S41486001	1	ヌノオサエL-JL6	CLOTH PRESSER (L-J)(L6)	
1-3	S43342000	1	981シヨウハーネスL6	HARNES 981(L6)	
1-5	S37199001	1	ハンマー30	HAMMER (30)	
1-6	S37201001	1	ハンマー34	HAMMER (34)	
<b>&lt;L7 36-40mm&gt;</b>					
1-2	S41475101	1	L7プレートLクミ	(L7) PLATE (L) ASSY	
1-2-1	S41492101	1	オサエプレートJL7ソウクミ	CLOTH PRESSER PLATE (J)(L7) SET	
1-2-1-2	S41482001	1	ハリイタL7L	NEEDLE PLATE (L7)(L)	
1-2-1-4	S41488001	1	ヌノオサエL-JL7	CLOTH PRESSER (L-J)(L7)	
1-3	S43343000	1	981シヨウハーネスL7	HARNES 981(L7)	
1-5	S37201001	1	ハンマー34	HAMMER (34)	
1-6	S35093001	1	ハンマー38	HAMMER (38)	
1-2-1-1	S35310001	1	ヌノオサエプレートLクミ	CLOTH PRESSER PLATE (L) ASSY	
1-2-1-1-1	S35316001	1	カクコマササエイタ	SLIDE BLOCK SUPPORT PLATE	
1-2-1-1-2	060020416	2	バインドM2X4	SCREW, BIND M2X4	
1-2-1-3	S06696004	2	サラコネジ3X6	SCREW, FLAT M3X6	
1-2-1-5	S35236000	1	マゲザガネ3.2	BENDING WASHER, M3.2	
1-2-1-6	S35235001	1	クランプササエピン	CLAMP SUPPORT PIN	
1-2-1-7	021300302	1	3シユナツト3	NUT, 3 M3	
1-2-1-8	S37712001	1	クランプジクウケ	CLAMP SHAFT HOLDER	
1-2-1-9	062401016	2	ナベコ4X10	SCREW, PAN M4X10	
1-2-1-10	S37711001	1	クランプシテンジク	CLAMP FULCRUM SHAFT	
1-2-1-11	048050142	2	トメワジクヨウC5	RETAINING RING, C5	
1-2-1-12	S35233201	1	クランプレバーL	CLAMP LEVER (L)	
1-2-1-13	018501236	1	アナボルト5X12	BOLT, SOCKET M5X12	
1-2-1-14	S40827001	1	クランプアームL-J-B	CLAMP ARM (L-J-B)	
1-2-1-15	014400532	2	アナクボミ4X5	SET SCREW, SOCKET (CP) M4X5	
1-2-1-16	S35348000	1	ヌノガイドL	CLOTH GUIDE (L)	
1-2-1-17	060350616	1	バインド3.5X6	SCREW, BIND M3.5X6	
1-2-2	S37714001	1	ホジヨオサエシテンダイ	SUB PRESSER FULCRUM BRACKET	
1-2-3	S37713001	1	ホジヨオサエシテンジク	SUB PRESSER FULCRUM SHAFT	
1-2-4	048050142	2	トメワジクヨウC5	RETAINING RING, C5	
1-2-5	S37718000	1	ホジヨオサエウデ	SUB PRESSER ARM	
1-2-6	018401032	1	アナボルト4X10	BOLT 4X10	
1-2-7	S05356000	1	ボタンオサエA	BUTTON PRESSER (A)	
1-2-8	S08808001	1	ストップネジ	STOPPER SCREW	
1-2-9	021660102	1	ナツト1シユ3.18	NUT, 1 SM3.18	
1-2-10	S37753001	1	ホジヨオサエモドシバネ	SUB PRESSER SPRING	
1-4	S04557000	1	バンタイPLTIM	BAND PLTIM	

From the library of: Diamond Needle Corp

b. 付属装置セット / Attachment set / Anbausatz / Jeu d'accessoires / Juego de fijación

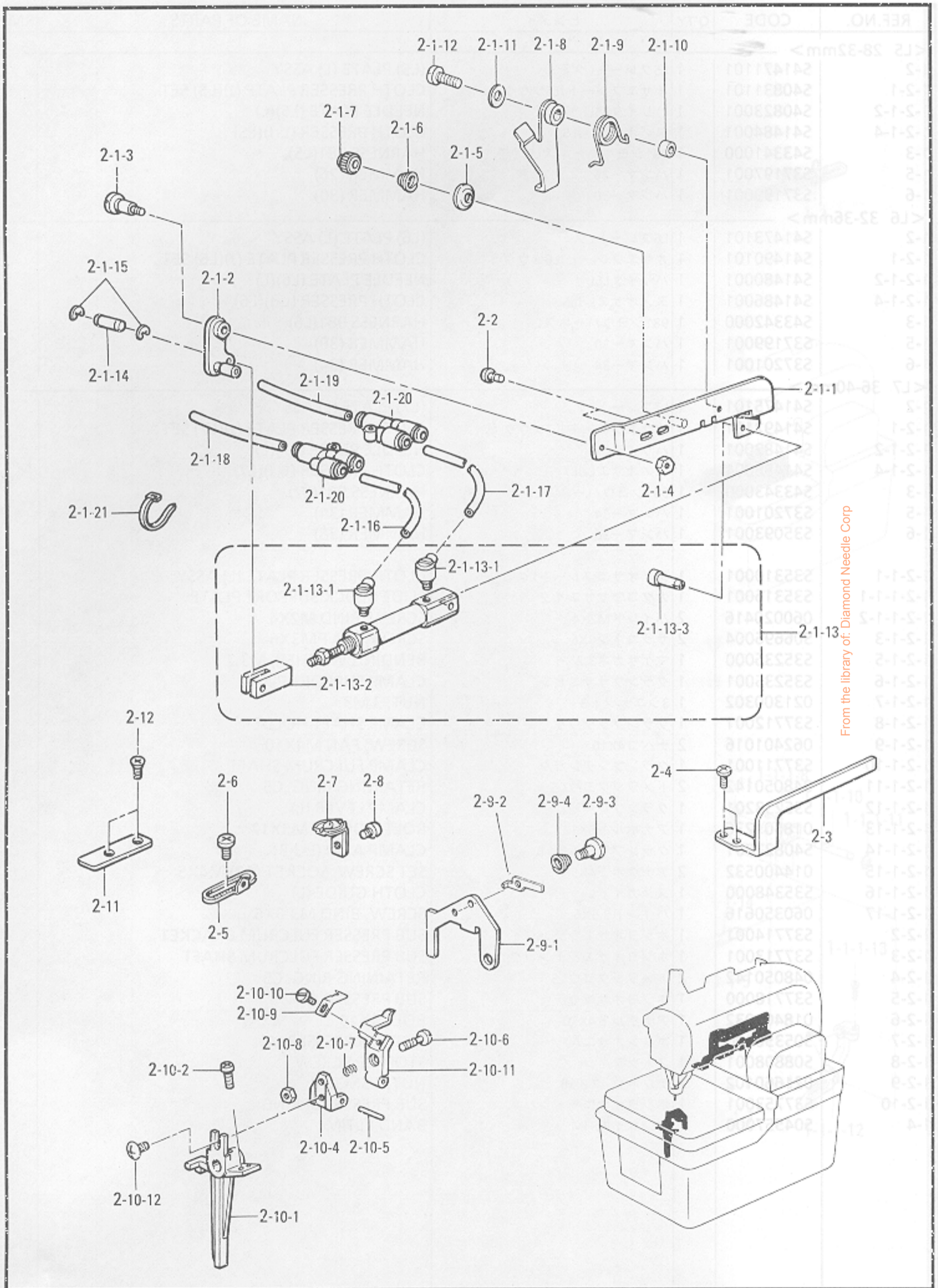

b. 付属装置セット / Attachment set / Anbausatz / Jeu d'accessoires / Juego de fijación

REF.NO.	CODE	Q'TY	ヒンメイ	NAME OF PARTS	RM
2	S38584001	1	クミカエブヒンクミ(-2)	EXCHANGE PARTS ASSY (-2)	
2-1	S38585001	1	シリンダササエクミ	SYLINDER SUPPORT ASSY	
2-1-1	S37744001	1	Fオサエシリンダササエクミ	SUB PRESSER SYLINDER SUPPORT ASSY	
2-1-2	S37717001	1	ホジヨオサエリンククミ	SUB PRESSER LINK ASSY	
2-1-3	S34922101	1	ダンネジM4	SHOULDER SCREW, M4	
2-1-4	021400202	1	2シユナツト4	NUT, 2 M4	
2-1-5	144504001	1	イトアンナイサラ	THREAD GUIDE DISC	
2-1-6	154562001	1	プレテンションバネB	SPRING, PRE-TENSION (B)	
2-1-7	155510001	1	イトチヨウシナツト	TENSION NUT	
2-1-8	S37745001	1	シナイトユルメイタ	GIMP THREAD RELEASE PLATE	
2-1-9	S37749001	1	シナイトユルメイタバネ	GIMP THREAD RELEASE PLATE SPRING	
2-1-10	147236001	1	メストリツケウデコロ	KNIFE SET ARM ROLLER	
2-1-11	025040232	1	ヒラザガネチユウ4	WASHER, PLAIN M 4	
2-1-12	062401212	1	ナベコ4X12	SCREW, PAN M4X12	
2-1-13	S37737001	1	シリンダ10X15Jクミ	SYLINDER	
2-1-13-1	S12150000	2	ホースエルボM-5HL-4	TUBE ELBOW, M-5HL-4	
2-1-13-2	S35351001	1	シリンダロッド	CYLINDER ROD	
2-1-13-3	S37866000	1	クレビスピン	CLEVIS PIN	
2-1-14	S35305001	1	シリンダロッドピン	CYLINDER ROD PIN	
2-1-15	048030342	2	トメワE3	RETAINING RING, E3	
2-1-16	S37738000	1	エア-ホース4X2.5-20	AIR TUBE 4X2.5-20 (L = 1350)	
2-1-17	S37739000	1	エア-ホース4X2.5-21	AIR TUBE 4X2.5-21 (L = 1400)	
2-1-18	S37863000	1	エア-ホース4X2.5-3J	AIR TUBE, 4X2.5-21 (L = 100)	
2-1-19	S37864000	1	エア-ホース4X2.5-4J	AIR TUBE, 4X2.5-21 (L = 100)	
2-1-20	S12104000	2	ユニオンワイ4	UNION-Y 4	
2-1-21	S04557000	1	バンタイPLTIM	BAND, PLTIM	
2-2	062400812	2	ナベコ4X8	SCREW, PAN M4X8	
2-3	S37750001	1	シナイトトリアンナイJ	GIMP THREAD TAKE-UP GUIDE (J)	
2-4	062400812	2	ナベコ4X8	SCREW, PAN M4X8	
2-5	S37697001	1	シナイトアンナイJ	GIMP THREAD GUIDE (J)	
2-6	062400812	1	ナベコ4X8	SCREW, PAN M4X8	
2-7	S37752001	1	スロートプレート1.8-J	THROAT PLATE 1.8(J)	
2-8	S35326001	1	シメネジM3.5	SCREW, M3.5	
2-9	S39109101	1	シナイトアンナイC-Jクミ	GIMP GUIDE (C-J) ASSY	
2-9-1	S37696101	1	シナイトアンナイC-J	GIMP GUIDE (C-J)	
2-9-2	S41252000	1	シナイトオサエイターJ	GIMP THREAD WORK CLAMP-J	
2-9-3	159113001	1	ダンネジ3.18	SHOULDER SCREW, SM3.18	
2-9-4	S35118001	1	ハライトチヨウシバネ	TENSION SPRING	
2-10	S39108001	1	レバードダイBクミ	LEVER BRACKET (B) ASSY	
2-10-1	S37726001	1	イトキリレバードダイB	THREAD TRIMMER LEVER BRACKET (B)	
2-10-2	062301016	1	ナベコM3X10	SCREW, PAN M3X10	
2-10-4	S37721001	1	シタイトオサエダイ	LOWER THREAD PRESSER BRACKET	
2-10-5	148407001	1	ヨコアンナイミゾピンL	DOWEL PIN (L)	
2-10-6	S37724001	1	シメネジ2.38	SCREW, M2.38	
2-10-7	S37725001	1	シタイトオサエバネ	LOWER THREAD PRESSER SPRING	
2-10-8	021630102	1	ナツト1シユ2.	NUT, 1 M2	
2-10-9	S37723001	1	ウワイドウハB	UPPER MOVABLE KNIFE (B)	
2-10-10	105288001	1	シメネジ2.38	SCREW, SM2.38	
2-10-11	S37720001	1	シタイトオサエ	LOWER THREAD PRESSER	
2-10-12	060350616	1	バインド3.5X6	SCREW, BIND M3.5X6	
2-11	S37693001	1	プレートガイドイタC	PLATE GUIDE (C)	
2-12	S06696004	2	サラコネジ3X6	SCREW, FLAT M3X6	
1-8	S37758001	1	メノオサエR-L4	CLOTH PRESSER (R-J)(L4)	
1-9	S37759001	1	メノオサエL-R4	CLOTH PRESSER (L-J)(L4)	
1-10	S43340000	1	981シヨウハーネスL4	HARNESS 981(L4)	
1-11	S37708001	1	ハンマーS24	HAMMER (S24)	
1-12	S42053001	1	ハンマーS28	HAMMER (S28)	
1-13	144749001	1	ポリフクロ	PE. BAG	

From the library of: Diamond Needle Corp



c. 付属装置セット / Attachment set / Anbausatz / Jeu d'accessoires / Juego de fijación

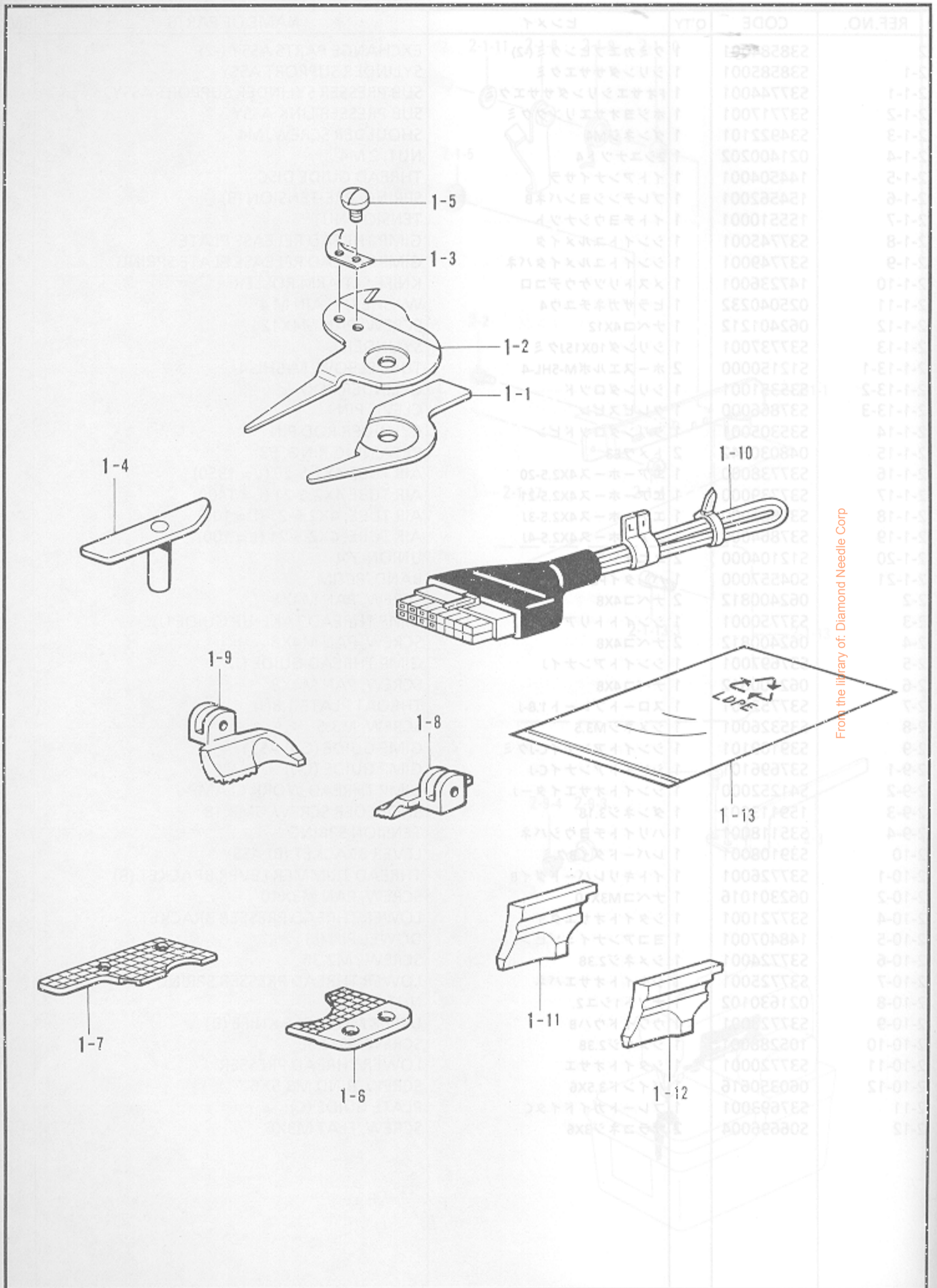

From the library of: Diamond Needle Corp

c. 付属装置セット / Attachment set / Anbausatz / Jeu d'accessoires / Juego de fijación

REF.NO.	CODE	Q'TY	ヒンメイ	NAME OF PARTS	RM
<b>&lt;L1 14 - 18mm&gt;</b>					
1	S44275001	1	コウカンパーツL1クミ	EXCHANGE PARTS (L1) ASSY	
1-1	S37673101	1	イドウハL1R	MOVABLE KNIFE (L1)(R)	
1-2	S37669101	1	イドウハL1L	MOVABLE KNIFE (L1)(L)	
1-3	S37665000	1	イトサバキL1	THREAD HANDLER L1	
1-4	S37661001	1	イドウハクドウカムL1	MOVABLE KNIFE DRIVING CAM (L1)	
1-5	153787001	2	シメネジ2.38	SCREW, M2.38	
1-6	S37644101	1	ハリイタL1R	NEEDLE PLATE (L1)(R)	
1-7	S37643201	1	ハリイタL1L	NEEDLE PLATE (L1)(L)	
1-8	S37754001	1	ヌノオサエR-JL1	CLOTH PRESSER (R-J)(L1)	
1-9	S37755001	1	ヌノオサエL-JL1	CLOTH PRESSER (L-J)(L1)	
1-10	S43337000	1	981シヨウハーネスL1	HARNESS 981(L1)	
1-11	S37702001	1	ハンマーS12	HAMMER (S12)	
1-12	S37704001	1	ハンマーS16	HAMMER (S16)	
1-13	144749001	1	ポリフクロ	PE. BAG	
<b>&lt;L2 18 - 22mm&gt;</b>					
1	S44276001	1	コウカンパーツL2クミ	EXCHANGE PARTS (L2) ASSY	
1-1	S37674101	1	イドウハL2R	MOVABLE KNIFE (L2)(R)	
1-2	S37670101	1	イドウハL2L	MOVABLE KNIFE (L2)(L)	
1-3	S37666000	1	イトサバキL2	THREAD HANDLER L2	
1-4	S37662001	1	イドウハクドウカムL2	MOVABLE KNIFE DRIVING CAM (L2)	
1-5	153787001	2	シメネジ2.38	SCREW, M2.38	
1-6	S37646101	1	ハリイタL2R	NEEDLE PLATE (L2)(R)	
1-7	S37645201	1	ハリイタL2L	NEEDLE PLATE (L2)(L)	
1-8	S37690001	1	ヌノオサエR-JL2	CLOTH PRESSER (R-J)(L2)	
1-9	S37689001	1	ヌノオサエL-JL2	CLOTH PRESSER (L-J)(L2)	
1-10	S43338000	1	981シヨウハーネスL2	HARNESS 981(L2)	
1-11	S37704001	1	ハンマーS16	HAMMER (S16)	
1-12	S37706001	1	ハンマーS20	HAMMER (S20)	
1-13	144749001	1	ポリフクロ	PE. BAG	
<b>&lt;L3 22 - 26mm&gt;</b>					
1	S44277001	1	コウカンパーツL3クミ	EXCHANGE PARTS (L3) ASSY	
1-1	S37675101	1	イドウハL3R	MOVABLE KNIFE (L3)(R)	
1-2	S37671101	1	イドウハL3L	MOVABLE KNIFE (L3)(L)	
1-3	S37667000	1	イトサバキL3	THREAD HANDLER L3	
1-4	S37663001	1	イドウハクドウカムL3	MOVABLE KNIFE DRIVING CAM (L3)	
1-5	153787001	2	シメネジ2.38	SCREW, M2.38	
1-6	S37648101	1	ハリイタL3R	NEEDLE PLATE (L3)(R)	
1-7	S37647101	1	ハリイタL3L	NEEDLE PLATE (L3)(L)	
1-8	S37692001	1	ヌノオサエR-JL3	CLOTH PRESSER (R-J)(L3)	
1-9	S37691001	1	ヌノオサエL-JL3	CLOTH PRESSER (L-J)(L3)	
1-10	S43339000	1	981シヨウハーネスL3	HARNESS 981(L3)	
1-11	S37706001	1	ハンマーS20	HAMMER (S20)	
1-12	S37708001	1	ハンマーS24	HAMMER (S24)	
1-13	144749001	1	ポリフクロ	PE. BAG	
<b>&lt;L4 26 - 30mm&gt;</b>					
1	S44278001	1	コウカンパーツL4クミ	EXCHANGE PARTS (L4) ASSY	
1-1	S37676101	1	イドウハL4R	MOVABLE KNIFE (L4)(R)	
1-2	S37672101	1	イドウハL4L	MOVABLE KNIFE (L4)(L)	
1-3	S37668000	1	イトサバキL4	THREAD HANDLER L4	
1-4	S37664001	1	イドウハクドウカムL4	MOVABLE KNIFE DRIVING CAM (L4)	
1-5	153787001	2	シメネジ2.38	SCREW, M2.38	
1-6	S37650101	1	ハリイタL4R	NEEDLE PLATE (L4)(R)	
1-7	S37649101	1	ハリイタL4L	NEEDLE PLATE (L4)(L)	
1-8	S37758001	1	ヌノオサエR-JL4	CLOTH PRESSER (R-J)(L4)	
1-9	S37759001	1	ヌノオサエL-JL4	CLOTH PRESSER (L-J)(L4)	
1-10	S43340000	1	981シヨウハーネスL4	HARNESS 981(L4)	
1-11	S37708001	1	ハンマーS24	HAMMER (S24)	
1-12	S42053001	1	ハンマーS28	HAMMER (S28)	
1-13	144749001	1	ポリフクロ	PE. BAG	

From the library of: Diamond Needle Corp

c. 付属装置セット / Attachment set / Anbausatz / Jeu d'accessoires / Juego de fijación

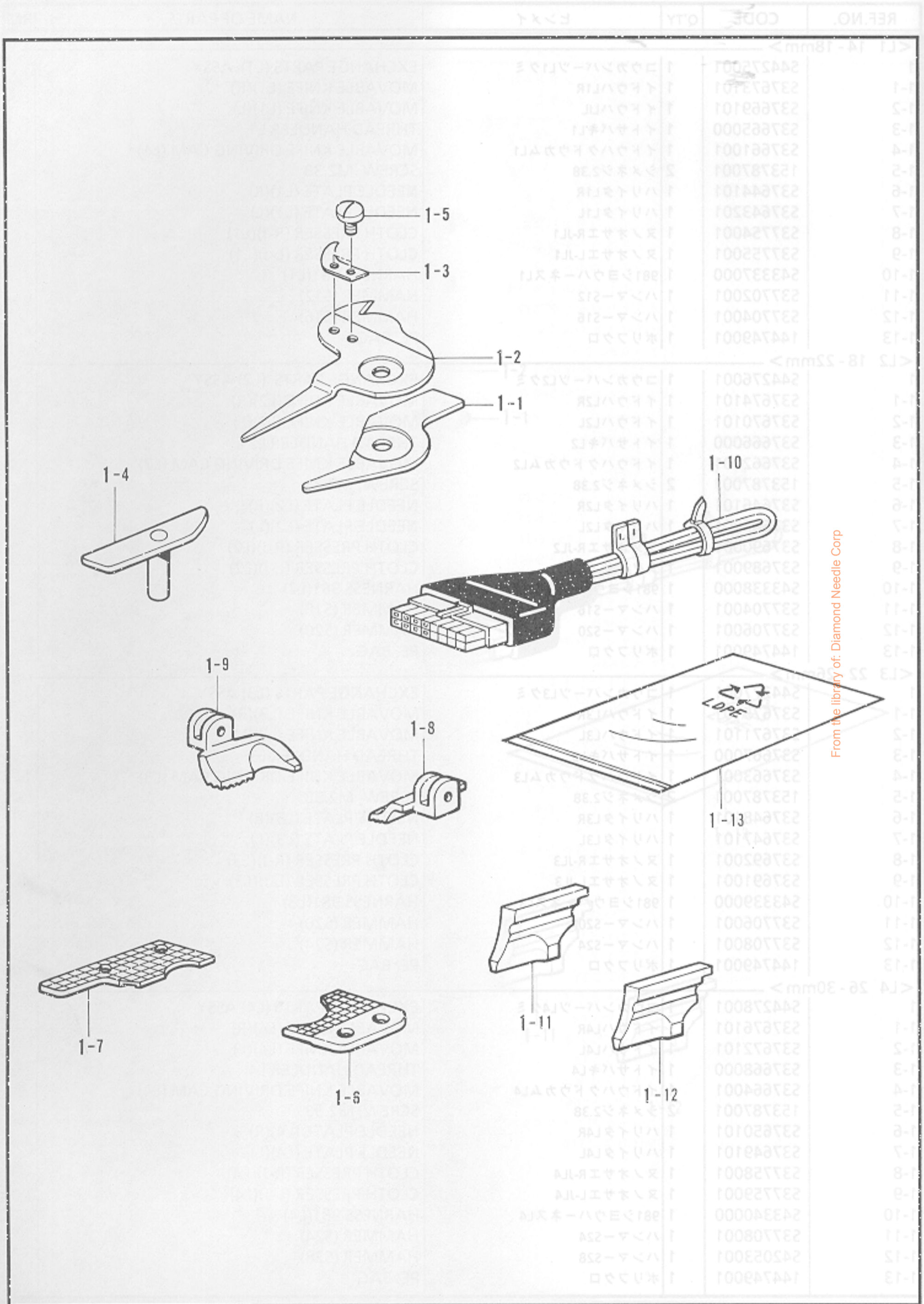

From the library of: Diamond Needle Corp

c. 付属装置セット / Attachment set / Anbausatz / Jeu d'accessoires / Juego de fijación

REF.NO.	CODE	Q'TY	ヒンメイ	NAME OF PARTS	RM
<L5 28-32mm>					
1	S44283001	1	コウカンパーツL5クミ	EXCHANGE PARTS (L5) ASSY	
1-1	S37674101	1	イドウハL2R	MOVABLE KNIFE (L2)(R)	
1-2	S37670101	1	イドウハL2L	MOVABLE KNIFE (L2)(L)	
1-3	S37666000	1	イトサバキL2	THREAD HANDLER L2	
1-4	S37662001	1	イドウハクドウカムL2	MOVABLE KNIFE DRIVING CAM (L2)	
1-5	153787001	2	シメネジ2.38	SCREW, M2.38	
1-6	S40822001	1	ハリイタL5R	NEEDLE PLATE (L5)(R)	
1-7	S40823001	1	ハリイタL5L	NEEDLE PLATE (L5)(L)	
1-8	S41483001	1	ヌノオサエR-JL5	CLOTH PRESSER (R-J)(L5)	
1-9	S41484001	1	ヌノオサエL-JL5	CLOTH PRESSER (L-J)(L5)	
1-10	S43341000	1	981シヨウハーネスL5	HARNES 981(L5)	
1-11	S37197001	1	ハンマー26	HAMMER (26)	
1-12	S37199001	1	ハンマー30	HAMMER (30)	
1-13	144749001	1	ポリフクロ	PE. BAG	
<L6 32-36mm>					
1	S44284001	1	コウカンパーツL6クミ	EXCHANGE PARTS (L6) ASSY	
1-1	S37675101	1	イドウハL3R	MOVABLE KNIFE (L3)(R)	
1-2	S37671101	1	イドウハL3L	MOVABLE KNIFE (L3)(L)	
1-3	S37667000	1	イトサバキL3	THREAD HANDLER L3	
1-4	S37663001	1	イドウハクドウカムL3	MOVABLE KNIFE DRIVING CAM (L3)	
1-5	153787001	2	シメネジ2.38	SCREW, M2.38	
1-6	S41479001	1	ハリイタL6R	NEEDLE PLATE (L6)(R)	
1-7	S41480001	1	ハリイタL6L	NEEDLE PLATE (L6)(L)	
1-8	S41485001	1	ヌノオサエR-JL6	CLOTH PRESSER (R-J)(L6)	
1-9	S41486001	1	ヌノオサエL-JL6	CLOTH PRESSER (L-J)(L6)	
1-10	S43342000	1	981シヨウハーネスL6	HARNES 981(L6)	
1-11	S37199001	1	ハンマー30	HAMMER (30)	
1-12	S37201001	1	ハンマー34	HAMMER (34)	
1-13	144749001	1	ポリフクロ	PE. BAG	
<L7 36-40mm>					
1	S44285001	1	コウカンパーツL7クミ	EXCHANGE PARTS (L7) ASSY	
1-1	S37676101	1	イドウハL4R	MOVABLE KNIFE (L4)(R)	
1-2	S37672101	1	イドウハL4L	MOVABLE KNIFE (L4)(L)	
1-3	S37668000	1	イトサバキL4	THREAD HANDLER L4	
1-4	S37664001	1	イドウハクドウカムL4	MOVABLE KNIFE DRIVING CAM (L4)	
1-5	153787001	2	シメネジ2.38	SCREW, M2.38	
1-6	S41481001	1	ハリイタL7R	NEEDLE PLATE (L7)(R)	
1-7	S41482001	1	ハリイタL7L	NEEDLE PLATE (L7)(L)	
1-8	S41487001	1	ヌノオサエR-JL7	CLOTH PRESSER (R-J)(L7)	
1-9	S41488001	1	ヌノオサエL-JL7	CLOTH PRESSER (L-J)(L7)	
1-10	S43343000	1	981シヨウハーネスL7	HARNES 981(L7)	
1-11	S37201001	1	ハンマー34	HAMMER (34)	
1-12	S35093001	1	ハンマー38	HAMMER (38)	
1-13	144749001	1	ポリフクロ	PE. BAG	

From the library of: Diamond Needle Corp

d. 付属装置セット / Attachment set / Anbausatz / Jeu d'accessoires / Juego de fijación

REF. NO.	CODE	QTY	NAME
1-13	14479001	1	1 糸リッパ口
1-12	23719001	1	1 ハンマー30
1-11	23719001	1	1 ハンマー28
1-10	243341000	1	1 981シヨウハース
1-9	247484001	1	1 スノセエ
1-8	247483001	1	1 スノセエ
1-7	240823001	1	1 ハリ
1-6	240822001	1	1 ハリ
1-5	153787001	2	2 スノセ
1-4	237862001	1	1 トクハ
1-3	23786000	1	1 トクハ
1-2	237870101	1	1 トクハ
1-1	237874101	1	1 トクハ
	244283001	1	1 コウカン

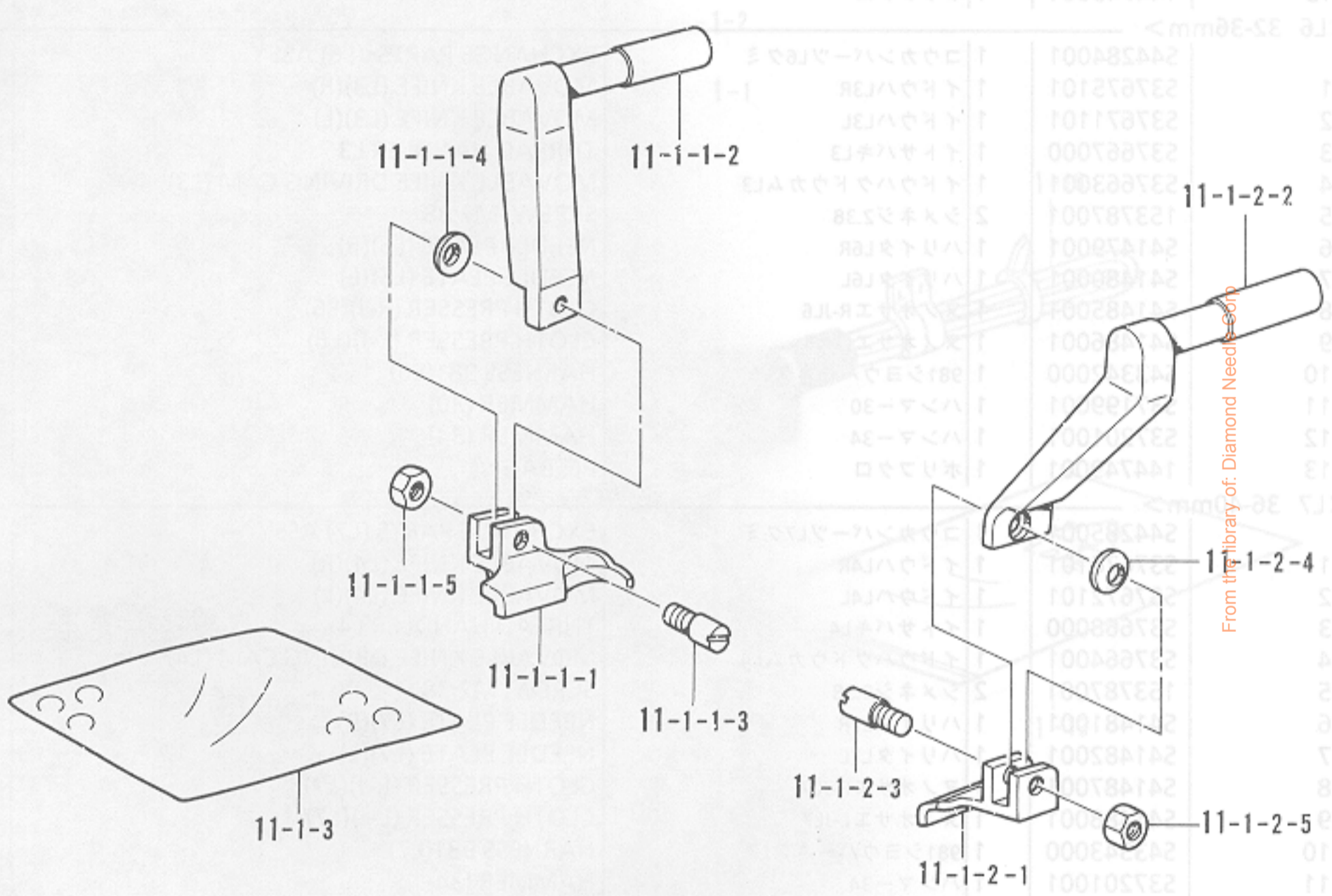







d. 付属装置セット / Attachment set / Anbausatz / Jeu d'accessoires / Juego de fijación

REF.NO.	CODE	Q'TY	ヒンメイ	NAME OF PARTS	RM
<b>&lt;ウエストベルトオサエL3ヨウ / FOR WAIST BELT PRESSER (L3)&gt;</b>					
11-1	S43701001	1	ヌノオサエL3Wセット	CLOTH PRESSER (L3W) SET	
11-1-1	S43702001	1	ヌノオサエL-L3Wクミ	CLOTH PRESSER (L-L3W) ASSY	
11-1-1-1	S43408001	1	ヌノオサエL-L3W	CLOTH PRESSER, L-L3W	
11-1-1-2	S43450001	1	クランプアームL-JW	CLAMP ARM, L-JW	
11-1-1-3	S35235001	1	クランプササエピン	CLAMP SUPPORT PIN	
11-1-1-4	S35236000	1	マゲザガネ3.2	BENDING WASHER, M3.2	
11-1-1-5	021300302	1	3シユナツト3	NUT, 3 M3	
11-1-2	S43703001	1	ヌノオサエR-L3Wクミ	CLOTH PRESSER (R-L3W) ASSY	
11-1-2-1	S43409001	1	ヌノオサエR-L3W	CLOTH PRESSER, R-L3W	
11-1-2-2	S43451001	1	クランプアームR-JW	CLAMP ARM, R-JW	
11-1-2-3	S35235001	1	クランプササエピン	CLAMP SUPPORT PIN	
11-1-2-4	S35236001	1	マゲザガネ3.2	BENDING WASHER, M3.2	
11-1-2-5	021300302	1	3シユナツト3	NUT, 3 M3	
11-1-3	S60011000	1	200X250キホウフクロ	POLYVINYL BAG, 200X250	
<b>&lt;ウエストベルトオサエL4ヨウ / FOR WAIST BELT PRESSER (L4)&gt;</b>					
11-1	S43704001	1	ヌノオサエL4Wセット	CLOTH PRESSER (L4W) SET	
11-1-1	S43705001	1	ヌノオサエL-L4Wクミ	CLOTH PRESSER (L-L4W) ASSY	
11-1-1-1	S43410001	1	ヌノオサエL-L4W	CLOTH PRESSER, L-L4W	
11-1-1-2	S43450001	1	クランプアームL-JW	CLAMP ARM, L-JW	
11-1-1-3	S35235001	1	クランプササエピン	CLAMP SUPPORT PIN	
11-1-1-4	S35236000	1	マゲザガネ3.2	BENDING WASHER, M3.2	
11-1-1-5	021300302	1	3シユナツト3	NUT, 3 M3	
11-1-2	S43706001	1	ヌノオサエR-L4Wクミ	CLOTH PRESSER (R-L4W) ASSY	
11-1-2-1	S43411001	1	ヌノオサエR-L4W	CLOTH PRESSER, R-L4W	
11-1-2-2	S43451001	1	クランプアームR-JW	CLAMP ARM, R-JW	
11-1-2-3	S35235001	1	クランプササエピン	CLAMP SUPPORT PIN	
11-1-2-4	S35236001	1	マゲザガネ3.2	BENDING WASHER, M3.2	
11-1-2-5	021300302	1	3シユナツト3	NUT, 3 M3	
11-1-3	S60011000	1	200X250キホウフクロ	POLYVINYL BAG, 200X250	



From the library of: Diamond Needle Corp

仕様別部品一覧表/DIFFERENT PARTS LIST/ZUBEHÖRLISTE/  
LISTE DES PIÈCES ACCESSOIRES/LISTA DE PIEZAS ACCESORIAS

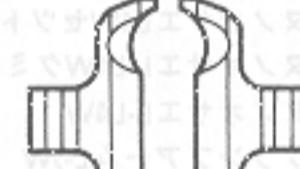
Ref.No. F-80-2-4,81-2-4 ヌノオサエ / CLOTH PRESSER

(L)	S37755-001	S37689-001	S37691-001	S37759-001
(R)	S37754-001	S37690-001	S37692-001	S37758-001
(-02 -52用)	L1<14~18mm用> 	L2<18~22mm用> 	L3<22~26mm用> 	L4<26~30mm用> 
	S41484-001	S41486-001	S41488-001	
	S41483-001	S41485-001	S41487-001	
	L5<28~32mm用> 	L6<32~36mm用> 	L7<36~40mm用> 	

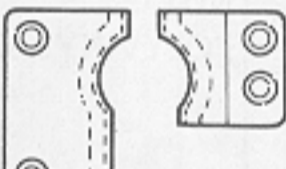
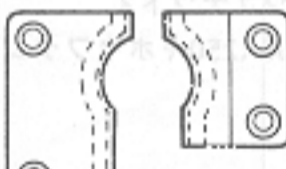
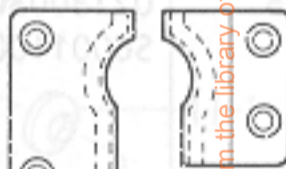
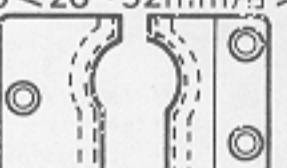
Ref.No. F-80-2-2,81-2-2 ハリイタ / NEEDLE PLATE

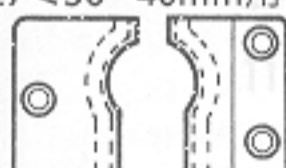
(L)	S37643-101(L1L)	S37645-101(L2L)	S37647-101(L3L)	S37649-101(L4L)
(R)	S37644-101(L1R)	S37646-101(L2R)	S37648-101(L3R)	S37650-101(L4R)
(-02 -52用)	L1<14~18mm用> 	L2<18~22mm用> 	L3<22~26mm用> 	L4<26~30mm用> 
	S40823-001(L5L)	S41480-001(L6L)	S41482-001(L7L)	
	S41822-001(L5R)	S41479-001(L6R)	S41481-001(L7R)	
	L5<28~32mm用> 	L6<32~36mm用> 	L7<36~40mm用> 	

Ref.No. H-24 ハンマー / HAMMER

(L1 L4)	サイズ(mm)	S10	S12	S14	S16	S18
	部品コード	S37701-001	S37702-001	S37703-001	S37704-001	S37705-001
(L5 L7)	サイズ(mm)	S20	S22	S24	S26	
	部品コード	S37706-001	S37707-001	S37708-001	S37709-001	
(L5 L7)	サイズ(mm)	20	22	24	26	28
	部品コード	S35092-001	S37195-001	S37196-001	S37197-001	S37198-001
	サイズ(mm)	30	32	34	36	38
	部品コード	S37199-001	S37200-001	S37201-001	S37202-001	S35093-001

From the library of: Diamond Needle Corp

仕様別部品一覧表/DIFFRENT PARTS LIST/ZUBEHÖRLISTE/  
LISTE DES PIECES ACCESSOIRES/LISTA DE PIEZAS ACCESORIAS

Ref.No. H-34		メス / KNIFE		
S35439-101	S35437-101	S35480-101	S35482-101	S35408-101 (S)
<38mm用>	<38mm用>	<38mm用>	<38mm用>	<38mm用>

Ref.No. W-43 シヨウハーネス/HARNESS

(-02用)	仕様	L1	L2	L3	L4
	部品コード	S43337-000	S43338-000	S43339-000	S43340-000
	仕様	L5	L6	L7	
	部品コード	S43341-000	S43342-000	S43343-000	
(-52用)	仕様	L1	L2	L3	L4
	部品コード	S43360-000	S43361-000	S43362-000	S43363-000
	仕様	L5	L6	L7	
	部品コード	S43364-000	S43365-000	S43366-000	

From the library of: Diamond Needle Corp



索引 / INDEX / VERZEICHNIS  
/ INDEX / INDICE

CODE	REF.NO.	Page
J00686001	T - 3-3-3-2	38
S00480000	Y - 1-76	58
S00554000	U1 - 1-38	40
S01522000	Y - 1-68	58
S01542000	Y - 1-60-1-4	58
S02460001	G - 19	18
	G - 71	18
	G - 76	18
S02760000	Y - 1-71	58
S02766109	Z - 4	60
S02775001	Z - 4-4	60
S02779009	Z - 4-10	60
S02788009	Z - 4-11	60
S02789009	Z - 4-11-1	60
S02816000	Z - 4-14	60
S04557000	V - 38	46
	W - 5-4	52
	W - 14-5	52
	W - 44	52
	X - 1-12	54
	Y - 1-75	58
	b - 2-1-21	72
	a1 - 1-4	66
	a2 - 1-4	70
S04897000	Y - 1-60-1-5	58
	Y - 1-69	58
S05356000	F - 95	12
	Y - 1-33	56
	a1 - 1-2-7	66
	a2 - 1-2-7	70
S06696004	F - 55	12
	F - 80-2-3	14
	F - 80-2-3	16
	F - 81-2-3	14
	F - 81-2-3	16
	b - 2-12	72
	a1 - 1-1-1-3	64
	a1 - 1-2-1-3	66
	a2 - 1-1-1-3	68
	a2 - 1-2-1-3	70
S08030000	Z - 79	62
	U1 - 1-50-17	40
S08808001	F - 96	12
	a1 - 1-2-8	66
	a2 - 1-2-8	70
S10077100	G - 69	18
S10078001	G - 80	20
S10079001	G - 81	20
S10243000	V - 5	46
	W - 23	52
	W - 25	52
	W - 28	52
S10439001	M - 8	30
S10546000	W - 6-1-1	52
S10856001	W - 1-3	52
	W - 2-2	52
	W - 5-3	52
S11426000	Y - 1-5-2	56
S11433000	V - 9-3	46
	V - 31-1-2	46
	Y - 1-32-2	56
S11816000	V - 60	46
	W - 21-1	52

CODE	REF.NO.	Page
S11816000	W - 27	52
S11817000	V - 36	46
S11949000	U1 - 1-31	40
S12004000	G - 18	18
	G - 72	18
	G - 75	18
S12104000	V - 32	46
	V - 57	46
	b - 2-1-20	72
S12150000	V - 1-1	46
	V - 8-1	46
	V - 9-1	46
	V - 10-1	46
	V - 50-1	48
	Y - 1-15-3	56
	b - 2-1-13-1	72
S13955000	V - 45	46
S16568000	U1 - 1-20	40
S17608009	B - 65-1	6
S17965001	A - 61	2
S18707129	J - 17	24
S18707137	J - 18	24
S20681000	Q - 22	34
S20682102	Q - 21	34
S20696001	Q - 55	34
	Q - 70	34
S20698121	Q - 40	34
S21716001	R - 22	36
	a1 - 1-1-22	64
	a2 - 1-1-22	68
S21728001	A - 17	2
S21798001	Z - 4-8	60
S23612001	B - 38	6
	M - 15	30
	N - 9	30
S23651001	C - 4	8
	C - 6	8
	C - 8	8
	K - 7	24
	K - 9	24
	K - 11	24
S23880000	V - 42-3-1-4	50
S24325001	Y - 1-25	56
S27844101	G - 53	18
	G - 61	18
S29410001	G - 4	18
S30302000	Z - 4-4-3	60
	Z - 4-12-5	60
	Z - 4-13-4	60
S31568000	G - 79	20
S31760000	U1 - 1-39	40
S32264009	A - 91	4
S33899000	A - 78	4
S34881001	R - 12	36
	a1 - 1-1-12	64
	a2 - 1-1-12	68
S34906000	R - 19	36
	a1 - 1-1-19	64
	a2 - 1-1-19	68
S34913001	R - 1-3	36
S34914001	R - 1-1	36
S34915000	Z - 5	60
S34916001	V - 10-4	46

CODE	REF.NO.	Page
S34917001	Q - 1-1	34
S34918101	Q - 1-2	34
S34922101	F - 102	12
	Q - 1-4	34
	X - 1-7	54
	b - 2-1-3	72
S34923001	Q - 13	34
S34924001	Q - 26	34
S34925101	V - 1-2	46
S34928001	Q - 38	34
S34934001	Q - 52	34
S34948101	L - 1	26
S34950109	G - 1	18
S34957001	F - 1	12
S34963001	F - 2	12
S34964001	F - 2-1	12
S34965001	F - 1-1	12
S34966001	F - 3	12
	Q - 1-3	34
	X - 1-8	54
S34967001	F - 6	12
S34968000	F - 12	12
S34969001	F - 14	12
S34970001	F - 13	12
S34971001	P - 43	32
S34972000	P - 42	32
S34973000	P - 41	32
S34974000	P - 38	32
S34979000	P - 34	32
S34980000	P - 33	32
S34981000	P - 32	32
S34982000	P - 31	32
S34983000	P - 30	32
S34984000	P - 29	32
S34985000	P - 28	32
S34986000	P - 27	32
S34995000	P - 15	32
S34996001	P - 13	32
S34997001	P - 11	32
S34998001	P - 9	32
S34999001	P - 7	32
S35000001	P - 5	32
S35001000	P - 3	32
S35002000	P - 2	32
S35003101	P - 1	32
S35007000	L - 2	26
S35010001	L - 4	26
S35011001	L - 10	26
S35012001	L - 12	26
S35013001	L - 16	26
S35014001	L - 21	26
S35015001	L - 14	26
S35016001	L - 17	26
S35017001	L - 19	26
S35018001	L - 20	26
	L - 62	26
S35019001	L - 22	26
S35020001	L - 23	26
S35021000	L - 24	26
S35022001	L - 25	26
S35023001	L - 26	26
S35024101	L - 28	26
S35027001	L - 34	26

From the library of: Diamond Needle Corp

索引 / INDEX / VERZEICHNIS  
/ INDEX / INDICE

CODE	REF.NO.	Page
S35028000	L - 35	26
S35030001	L - 42	26
S35032101	L - 47	26
	L - 52	26
S35033001	L - 51	26
S35034001	L - 50	26
S35035001	L - 53	26
S35036001	L - 54	26
S35037001	L - 56	26
S35038001	L - 58	26
S35039000	L - 59	26
S35040000	L - 61	26
S35041000	L - 64	26
S35042000	L - 66	28
S35043001	L - 65	28
S35044001	L - 67	28
S35045001	L - 71	28
S35046000	L - 73	28
S35048101	L - 75	28
S35049001	L - 76	28
S35050001	L - 79	28
S35051001	L - 80	28
S35053001	L - 9	26
S35057001	L - 92	28
S35058001	S - 1	38
S35059001	S - 2	38
S35060001	S - 5	38
S35061000	M - 7	30
S35062001	M - 6	30
S35063001	M - 1-2	30
S35064001	M - 1-3	30
S35065001	M - 2	30
	N - 8	30
S35066001	M - 1	30
S35067001	M - 1-1	30
S35068001	N - 5	30
S35069001	N - 2-3	30
S35070101	N - 2-2	30
S35071001	N - 2-1	30
S35072101	N - 2	30
S35073001	N - 1	30
S35074101	H - 1	22
S35075101	H - 1-1	22
S35076101	H - 1-2	22
S35077000	H - 1-3	22
S35078001	B - 41	6
	H - 1-4	22
	H - 45	22
S35079000	H - 1-5	22
S35080001	H - 2	22
S35081001	H - 5	22
S35082001	H - 6	22
S35083001	H - 13	22
S35084001	H - 15	22
S35085001	H - 8	22
S35086001	H - 11	22
S35087001	H - 10	22
S35088001	H - 7	22
S35089001	H - 17	22
S35090001	H - 18	22
S35091001	H - 23	22
S35093001	c - 1-12	76
	a2 - 1-6	70

CODE	REF.NO.	Page
S35094201	H - 25-1	22
S35097001	H - 25-2	22
S35098000	H - 25-4	22
S35099001	H - 39	22
S35100001	H - 47	22
S35101001	H - 51	22
S35102001	H - 52	22
S35104001	H - 54	22
S35106001	J - 13	24
S35107001	J - 10	24
S35108001	J - 5	24
S35110001	J - 1-2	24
S35112001	J - 1	24
S35113001	B - 66	6
S35114001	B - 63	6
S35115001	B - 62	6
S35116001	B - 60	6
S35117001	B - 59	6
S35118001	B - 54	6
	L - 72	28
	L - 107	28
	b - 2-9-4	72
S35121000	B - 46	6
S35122000	B - 45	6
S35123000	B - 44	6
S35124000	B - 43	6
S35125000	B - 42	6
S35126001	B - 40	6
S35127001	B - 39	6
S35128001	B - 36	6
S35129001	B - 35-1	6
S35132101	B - 35	6
S35133118	Z - 7	60
S35134001	B - 32	6
S35135001	B - 30	6
S35136001	B - 29	6
S35137001	B - 28	6
S35138001	B - 26	6
S35142001	B - 25	6
S35143001	D - 24-1	8
	L - 7-1	26
S35144001	B - 22	6
S35148001	B - 19	6
S35154000	W - 5-1-1	52
S35162001	W - 14-2	52
S35164001	W - 2-3	52
S35165009	W - 17-1	52
S35166001	F - 41	12
S35169001	F - 16	12
S35174001	G - 51	18
S35176001	G - 2	18
S35177001	G - 3	18
S35178001	G - 12	18
S35179000	G - 15	18
S35180000	G - 11-1	18
S35181001	G - 11	18
S35182001	G - 23	18
S35183000	G - 26	18
S35184001	G - 27	18
	G - 73	18
S35185101	W - 1-2	52
S35186001	G - 55	18
S35187001	G - 96	20

CODE	REF.NO.	Page
S35188001	G - 16	18
S35189001	G - 63	18
S35190001	G - 70	18
S35191001	G - 74	18
S35192001	G - 84	20
S35193000	G - 84-1	20
S35194001	G - 85	20
S35195001	G - 91	20
S35196100	G - 89	20
S35201000	A - 40	2
S35202000	A - 81	4
S35203001	A - 23	2
S35204001	A - 76	4
S35206201	A - 69	2
S35207001	A - 67	2
S35211009	A - 66	2
S35212000	A - 63	2
S35214009	A - 62	2
S35215001	A - 59	2
S35216001	A - 57	2
S35217001	A - 55	2
S35218001	A - 47	2
S35219001	A - 44	2
S35220101	A - 41	2
S35221001	A - 38	2
	A - 70	2
S35222001	A - 37	2
S35223101	A - 34	2
S35224001	A - 26	2
S35225000	A - 15	2
S35226001	A - 11	2
S35227009	A - 8	2
S35228009	A - 9	2
S35229000	A - 7	2
S35231000	A - 3	2
S35233201	F - 81-2-12	14
	F - 81-2-12	16
	a1 - 1-2-1-12	56
	a2 - 1-2-1-12	70
S35234201	F - 80-2-12	14
	F - 80-2-12	16
	a1 - 1-1-1-12	64
	a2 - 1-1-1-12	68
S35235001	F - 80-2-6	14
	F - 80-2-6	16
	F - 81-2-6	14
	F - 81-2-6	16
	S - 10	38
	d - 11-1-1-3	78
	d - 11-1-1-3	78
	d - 11-1-2-3	78
	d - 11-1-2-3	78
	a1 - 1-1-1-6	64
	a1 - 1-2-1-6	66
	a2 - 1-1-1-6	68
	a2 - 1-2-1-6	70
S35236000	F - 80-2-5	14
	F - 80-2-5	16
	F - 81-2-5	14
	F - 81-2-5	16
	d - 11-1-1-4	78
	d - 11-1-1-4	78
	a1 - 1-1-1-5	64

CODE	REF.NO.	Page
S35236000	a1 - 1-2-1-5	66
	a2 - 1-1-1-5	68
	a2 - 1-2-1-5	70
S35236001	d - 11-1-2-4	78
	d - 11-1-2-4	78
S35237001	F - 80-2-10	14
	F - 80-2-10	16
	a1 - 1-1-1-10	64
	a2 - 1-1-1-10	68
S35238001	F - 80-2-8	14
	F - 80-2-8	16
	a1 - 1-1-1-8	64
	a2 - 1-1-1-8	68
S35239001	F - 35	12
S35240001	F - 36	12
S35245001	C - 7	8
S35246001	C - 5	8
S35247001	C - 3	8
S35249001	C - 16	8
S35250001	D - 20	8
S35251001	D - 21	8
S35252001	D - 18	8
S35255001	D - 17	8
S35256001	D - 15	8
S35257000	D - 12	8
S35258001	D - 10	8
S35259001	D - 6	8
S35260001	D - 5	8
S35262001	D - 4	8
S35263101	D - 2	8
S35264001	D - 1	8
S35265001	K - 12-2	24
S35268001	K - 12-1	24
S35269001	K - 12	24
S35270001	K - 10	24
S35272001	K - 8	24
S35273001	K - 4	24
S35274001	K - 6	24
S35275000	K - 3	24
S35276001	E - 1-1	10
S35283001	E - 1-5	10
S35284001	E - 11-1	10
	E - 23-1	10
S35287001	E - 23-4	10
S35288001	E - 23	10
S35290001	E - 11-4	10
S35291001	E - 11	10
S35296001	E - 15	10
S35297000	E - 17	10
S35298001	W - 5-2	52
S35299000	E - 32	10
S35300000	E - 31	10
S35302001	E - 35	10
S35303101	F - 39	12
S35304001	F - 44	12
S35305001	F - 42	12
	V - 3	46
	V - 12	46
	V - 51	48
	b - 2-1-14	72
S35310001	F - 81-2-1	16
	a2 - 1-2-1-1	70
S35315001	a1 - 1-1-1-1-1	64

CODE	REF.NO.	Page
S35315001	a2 - 1-1-1-1-1	68
S35316001	F - 80-2-1-1	14
	F - 80-2-1-1	16
	F - 81-2-1-1	14
	F - 81-2-1-1	16
	a1 - 1-2-1-1-1	66
	a2 - 1-2-1-1-1	70
S35321001	F - 53	12
S35322001	F - 54	12
S35323001	F - 56	12
S35324001	F - 57	12
S35326001	F - 80-2-17	14
	F - 80-2-17	16
	F - 81-2-17	14
	F - 81-2-17	16
	L - 90	28
	b - 2-8	72
S35327001	F - 62	12
S35328001	F - 67	12
S35331101	B - 17	6
S35332001	B - 15	6
	D - 22	8
S35333001	B - 14	6
S35334001	B - 13	6
S35335001	B - 12	6
S35337001	B - 8	6
S35338001	B - 10	6
S35339001	B - 2	6
S35340001	B - 7	6
S35346001	B - 1	6
S35347000	F - 80-2-16	14
	F - 80-2-16	16
	a2 - 1-1-1-16	68
S35347100	a1 - 1-1-1-16	64
S35348000	F - 81-2-16	14
	F - 81-2-16	16
	a2 - 1-2-1-16	70
S35348100	a1 - 1-2-1-16	66
S35349101	V - 1	46
S35350000	V - 7	46
S35351-00	V - 50-2	48
S35351001	V - 1-3	46
	V - 10-3	46
	b - 2-1-13-2	72
S35360000	V - 14	46
S35361001	S - 7	38
S35362001	S - 8	38
S35364001	S - 12	38
S35367000	V - 17	46
S35368000	V - 18	46
S35369000	V - 19	46
S35370000	V - 20	46
S35371000	V - 21	46
S35372000	V - 22	46
S35374000	V - 24	46
S35375000	V - 25	46
S35376000	V - 26	46
S35377100	V - 27	46
S35378100	V - 28	46
S35382000	V - 42-1-2	50
S35386000	V - 42-1-1	50
S35389001	V - 42-1	50
S35391001	L - 89-2	28

CODE	REF.NO.	Page
S35392001	L - 89-2	28
S35395000	V - 42-1-3	50
S35398100	V - 29	46
S35399100	V - 30	46
S35410001	L - 45	26
S35411001	L - 46-1	26
S35412001	L - 48	26
S35413001	L - 49-1	26
S35417000	V - 15	46
S35423000	V - 42-1-4	50
S35424000	V - 42-1-5	50
S35425001	V - 42-1-6	50
S35426000	V - 14-1	46
S35429001	F - 5	12
S35431001	J - 1-1	24
S35437101	H - 34	22
S35456001	F - 72	12
S35457001	F - 73	12
S35458001	F - 74	12
S35460000	V - 44	46
S35466001	Q - 30	34
S35471001	L - 46-2	28
S35472001	L - 49-2	28
S35473201	H - 25	22
S35909000	V - 16	46
S35911101	B - 35-3	6
S35912001	Q - 59	34
S36260000	X - 2-5-2	54
S36261000	Y - 1-23-	56
	Y - 1-35-	56
S36345000	F - 58	12
S36659001	L - 95	28
S36660001	L - 43	26
S37037001	Z - 4-12-	60
S37038001	Z - 4-12-	60
S37059001	U1 - 1-42	40
S37060001	U1 - 1-43	40
S37084001	A - 93	4
S37085001	A - 93-1	4
S37087001	B - 20	6
S37088001	B - 67	6
S37173000	P - 46	32
S37197001	c - 1-11	76
	a2 - 1-5	70
S37199001	c - 1-11	76
	c - 1-12	76
	a2 - 1-5	70
	a2 - 1-6	70
S37201001	c - 1-11	76
	c - 1-12	76
	a2 - 1-5	70
	a2 - 1-6	70
S37432001	B - 23	6
	D - 24	8
	L - 7	26
S37643101	F - 81-2-2	14
S37643201	c - 1-7	74
	a1 - 1-2-1-2	66
S37644101	F - 80-2-2	14
	c - 1-6	74
	a1 - 1-1-1-2	64
S37645101	F - 81-2-2	14
S37645201	c - 1-7	74

From the library of: Diamond Needle Corp

索引 / INDEX / VERZEICHNIS  
/ INDEX / INDICE

CODE	REF.NO.	Page
S37645201	a1 - 1-2-1-2	66
S37646101	F - 80-2-2	14
	c - 1-6	74
	a1 - 1-1-1-2	64
S37647101	F - 81-2-2	14
	c - 1-7	74
	a1 - 1-2-1-2	66
S37648101	F - 80-2-2	14
	c - 1-6	74
	a1 - 1-1-1-2	64
S37649101	F - 81-2-2	14
	c - 1-7	74
	a1 - 1-2-1-2	66
S37650101	F - 80-2-2	14
	c - 1-6	74
	a1 - 1-1-1-2	64
S37652001	R - 16	36
	a1 - 1-1-16	64
	a2 - 1-1-16	68
S37653001	R - 17	36
	a1 - 1-1-17	64
	a2 - 1-1-17	68
S37654000	R - 8	36
	a1 - 1-1-8	64
	a2 - 1-1-8	68
S37655101	R - 9	36
	a1 - 1-1-9	64
	a2 - 1-1-9	68
S37656001	R - 11	36
	a1 - 1-1-11-1	64
	a2 - 1-1-11-1	68
S37659001	R - 21	36
	a1 - 1-1-21	64
	a2 - 1-1-21	68
S37660101	R - 6	36
	a1 - 1-1-6	64
	a2 - 1-1-6	68
S37661001	R - 5	36
	c - 1-4	74
	a1 - 1-1-5	64
S37662001	R - 5	36
	c - 1-4	74
	c - 1-4	76
	a1 - 1-1-5	64
	a2 - 1-1-5	68
S37663001	R - 5	36
	c - 1-4	74
	c - 1-4	76
	a1 - 1-1-5	64
	a2 - 1-1-5	68
S37664001	R - 5	36
	c - 1-4	74
	c - 1-4	76
	a1 - 1-1-5	64
	a2 - 1-1-5	68
S37665000	R - 4	36
	c - 1-3	74
	a1 - 1-1-4	64
S37666000	R - 4	36
	c - 1-3	74
	c - 1-3	76
	a1 - 1-1-4	64
	a2 - 1-1-4	68

CODE	REF.NO.	Page
S37667000	R - 4	36
	c - 1-3	74
	c - 1-3	76
	a1 - 1-1-4	64
	a2 - 1-1-4	68
S37668000	R - 4	36
	c - 1-3	74
	c - 1-3	76
	a1 - 1-1-4	64
	a2 - 1-1-4	68
S37669101	R - 3	36
	c - 1-2	74
	a1 - 1-1-3	64
S37670101	R - 3	36
	c - 1-2	74
	c - 1-2	76
	a1 - 1-1-3	64
	a2 - 1-1-3	68
S37671101	R - 3	36
	c - 1-2	74
	c - 1-2	76
	a1 - 1-1-3	64
	a2 - 1-1-3	68
S37672101	R - 3	36
	c - 1-2	74
	c - 1-2	76
	a1 - 1-1-3	64
	a2 - 1-1-3	68
S37673101	R - 2	36
	c - 1-1	74
	a1 - 1-1-2	64
S37674101	R - 2	36
	c - 1-1	74
	c - 1-1	76
	a1 - 1-1-2	64
	a2 - 1-1-2	68
S37675101	R - 2	36
	c - 1-1	74
	c - 1-1	76
	a1 - 1-1-2	64
	a2 - 1-1-2	68
S37676101	R - 2	36
	c - 1-1	74
	c - 1-1	76
	a1 - 1-1-2	64
	a2 - 1-1-2	68
S37689001	F - 81-2-4	14
	c - 1-9	74
	a1 - 1-2-1-4	66
S37690001	F - 80-2-4	14
	c - 1-8	74
	a1 - 1-1-1-4	64
S37691001	F - 81-2-4	14
	c - 1-9	74
	a1 - 1-2-1-4	66
S37692001	F - 80-2-4	14
	c - 1-8	74
	a1 - 1-1-1-4	64
S37693001	F - 75	12
	b - 2-11	72
S37694001	F - 81-2-14	14
	a1 - 1-2-1-14	66
S37695001	F - 80-2-14	14

CODE	REF.NO.	Page
S37695001	a1 - 1-1-1-14	64
S37696001	L - 29	26
S37696101	b - 2-9-1	72
S37697001	Q - 57-2	34
	b - 2-5	72
S37700001	R - 24	36
	a1 - 1-1-24	64
	a2 - 1-1-24	68
S37702001	c - 1-11	74
	a1 - 1-5	66
S37704001	c - 1-11	74
	c - 1-12	74
	a1 - 1-5	66
	a1 - 1-6	66
S37706001	c - 1-11	74
	c - 1-12	74
	a1 - 1-5	66
	a1 - 1-6	66
S37708001	c - 1-11	74
	c - 1-12	74
	a1 - 1-5	66
	a1 - 1-6	66
S37711001	F - 81-2-10	14
	F - 81-2-10	16
	a1 - 1-2-1-10	66
	a2 - 1-2-1-10	70
S37712001	F - 81-2-8	14
	F - 81-2-8	16
	a1 - 1-2-1-8	66
	a2 - 1-2-1-8	70
S37713001	F - 91	12
	a1 - 1-2-3	66
	a2 - 1-2-3	70
S37714001	F - 90	12
	a1 - 1-2-2	56
	a2 - 1-2-2	70
S37717001	F - 101	12
	b - 2-1-2	72
S37718000	F - 93	12
	a1 - 1-2-5	66
	a2 - 1-2-5	70
S37720001	L - 38	26
	b - 2-10-11	72
S37721001	L - 101	28
	b - 2-10-4	72
S37723001	L - 36	26
	b - 2-10-9	72
S37724001	L - 103	28
	b - 2-10-6	72
S37725001	L - 104	28
S37726001	L - 31	26
	b - 2-10-1	72
S37727401	F - 80-2	14
	a1 - 1-1-1	64
S37728301	F - 81-2	14
	a1 - 1-2-1	66
S37729101	F - 80-2-1	14
	a1 - 1-1-1-1	64
S37730001	F - 81-2-1	14
	a1 - 1-2-1-1	66
S37731301	F - 81-2	14
	a1 - 1-2-1	66

索引 / INDEX / VERZEICHNIS  
/ INDEX / INDICE

CODE	REF.NO.	Page
S37732301	F - 81-2	14
	a1 - 1-2-1	66
S37733401	F - 80-2	14
	a1 - 1-1-1	64
S37735301	F - 81-2	14
	a1 - 1-2-1	66
S37737001	V - 50	48
	b - 2-1-13	72
S37738000	V - 53	48
	b - 2-1-16	72
S37739000	V - 54	48
	b - 2-1-17	72
S37744001	F - 99	12
	b - 2-1-1	72
S37745001	Q - 63	34
	b - 2-1-8	72
S37749001	Q - 64	34
	b - 2-1-9	72
S37750001	Q - 68	34
	b - 2-3	72
S37752001	L - 89	28
	b - 2-7	72
S37753001	F - 98	12
	a1 - 1-2-10	66
	a2 - 1-2-10	70
S37754001	F - 80-2-4	14
	c - 1-8	74
	a1 - 1-1-1-4	64
S37755001	F - 81-2-4	14
	c - 1-9	74
	a1 - 1-2-1-4	66
S37756401	F - 80-2	14
	a1 - 1-1-1	64
S37757401	F - 80-2	14
	a1 - 1-1-1	64
S37758001	F - 80-2-4	14
	c - 1-8	74
	a1 - 1-1-1-4	64
S37759001	F - 81-2-4	14
	c - 1-9	74
	a1 - 1-2-1-4	66
S37820001	R - 14	36
	a1 - 1-1-14-1	64
	a2 - 1-1-14-1	68
S37858000	R - 23	36
	a1 - 1-1-23	64
	a2 - 1-1-23	68
S37863000	V - 55	46
	b - 2-1-18	72
S37864000	V - 56	46
	b - 2-1-19	72
S37866-00	V - 50-3	48
S37866000	b - 2-1-13-3	72
S37870000	F - 104	12
S37874101	Q - 1	34
S38029000	X - 2-5	54
S38030000	X - 2-5-1	54
S38041000	Z - 76	62
S38051000	W - 53-1-1	52
S38059000	X - 2-20	54
S38060000	X - 2-19	54
S38073000	T - 3-1	38
S38080001	T - 5	38

CODE	REF.NO.	Page
S38094100	U1 - 1-12	40
S38107100	U1 - 1-23	40
S38108000	U1 - 1-24	40
S38109100	U1 - 1-25	40
S38110000	U1 - 1-26	40
S38112001	U2 - 5-1-1-2	42
S38112002	U2 - 5-5-1-2	42
S38114000	U2 - 5-2-1-2	42
S38117000	U2 - 5-3-1-2	42
	U2 - 5-3-1-2	42
S38117002	U2 - 5-8-1-2	44
	U2 - 5-9-1-2	44
S38123000	U2 - 5-1-1-10	42
	U2 - 5-5-1-10	42
S38124000	U2 - 5-2-1-10	42
	U2 - 5-8-1-10	44
S38127000	U2 - 5-3-1-10	42
	U2 - 5-3-1-10	42
	U2 - 5-9-1-10	44
S38143000	U1 - 1-62-1	40
S38155000	U1 - 1-53-3	40
S38164000	U1 - 1-53-4	40
S38166000	X - 2-1	54
S38170001	X - 2-4	54
S38174000	X - 2-8	54
S38175001	X - 2-9	54
S38176001	X - 2-10	54
S38177001	X - 2-14	54
S38180000	X - 2-18	54
S38200000	U1 - 1-50-7	40
S38201000	U1 - 1-50-9	40
S38576301	a1 - 1-1	64
S38577201	a1 - 1-2	66
S38578301	a1 - 1-1	64
S38579201	a1 - 1-2	66
S38580301	a1 - 1-1	64
S38581201	a1 - 1-2	66
S38582301	a1 - 1-1	64
S38583201	a1 - 1-2	66
S38584001	b - 2	72
S38585001	b - 2-1	72
S38648001	Z - 4-4-2	60
S38888001	L - 89-2	28
S39108001	b - 2-10	72
S39109101	b - 2-9	72
S39115000	Y - 1-60-1-1	58
S39116000	Y - 1-60-1-6	58
S39910001	X - 1-4	54
S39911001	X - 1-5	54
S39912001	X - 1-6	54
S39913001	X - 1-1	54
S39914001	X - 1-2	54
S40628000	V - 42-1-1-1	50
S40629000	V - 42-1-1-2	50
S40630000	V - 42-1-1-3	50
S40640001	Z - 4-7	60
S40641001	Z - 4-12	60
S40644001	Z - 4-13	60
S40676000	V - 59	46
S40677000	V - 58	46
S40822001	F - 80-2-2	16
	c - 1-6	76
	a2 - 1-1-1-2	68

CODE	REF.NO.	Page
S40823001	F - 81-2-2	16
	c - 1-7	76
	a2 - 1-2-1-2	70
S40826001	F - 80-2-14	16
	a2 - 1-1-1-14	68
S40827001	F - 81-2-14	16
	a2 - 1-2-1-14	70
S40828001	F - 80-2-1	16
	a2 - 1-1-1-1	68
S40830101	F - 80-2	16
	a2 - 1-1-1	68
S40831101	F - 81-2	16
	a2 - 1-2-1	70
S41251001	B - 69	6
S41252000	L - 106	28
	b - 2-9-2	72
S41310001	B - 52	6
S41451001	Y - 1-57	58
S41452000	Y - 1-58	58
S41470101	a2 - 1-1	68
S41471101	a2 - 1-2	70
S41472101	a2 - 1-1	68
S41473101	a2 - 1-2	70
S41474101	a2 - 1-1	68
S41475101	a2 - 1-2	70
S41479001	F - 80-2-2	16
	c - 1-6	76
	a2 - 1-1-1-2	68
S41480001	F - 81-2-2	16
	c - 1-7	76
	a2 - 1-2-1-2	70
S41481001	F - 80-2-2	16
	c - 1-6	76
	a2 - 1-1-1-2	68
S41482001	F - 81-2-2	16
	c - 1-7	76
	a2 - 1-2-1-2	70
S41483001	F - 80-2-4	16
	c - 1-8	76
	a2 - 1-1-1-4	68
S41484001	F - 81-2-4	16
	c - 1-9	76
	a2 - 1-2-1-4	70
S41485001	F - 80-2-4	16
	c - 1-8	76
	a2 - 1-1-1-4	68
S41486001	F - 81-2-4	16
	c - 1-9	76
	a2 - 1-2-1-4	70
S41487001	F - 80-2-4	16
	c - 1-8	76
	a2 - 1-1-1-4	68
S41488001	F - 81-2-4	16
	c - 1-9	76
	a2 - 1-2-1-4	70
S41489101	F - 80-2	16
	a2 - 1-1-1	68
S41490101	F - 81-2	16
	a2 - 1-2-1	70
S41491101	F - 80-2	16
	a2 - 1-1-1	68
S41492101	F - 81-2	16
	a2 - 1-2-1	70

索引 / INDEX / VERZEICHNIS  
/ INDEX / INDICE

CODE	REF.NO.	Page
S42053001	c - 1-12	74
	a1 - 1-6	66
S42111101	Y - 1-1	56
S42112100	Y - 1-4	56
S42113000	Y - 1-5	56
S42114000	Y - 1-5-1	56
	Y - 1-32-1	56
S42115101	Y - 1-6	56
S42116000	Y - 1-8	56
S42117101	Y - 1-10	56
S42118001	Y - 1-12	56
S42119001	Y - 1-14	56
S42120100	Y - 1-15	56
S42121000	Y - 1-15-1	56
S42122000	Y - 1-15-2	56
S42123001	Y - 1-16	56
S42124001	Y - 1-17	56
S42125100	Y - 1-19	56
S42126101	Y - 1-21	56
S42127000	Y - 1-23	56
S42128101	Y - 1-27	56
S42129101	Y - 1-29	56
S42132001	Y - 1-31	56
S42133000	Y - 1-32	56
S42134101	Y - 1-34	56
S42136000	Y - 1-35	56
S42137001	Y - 1-38	56
S42138101	Y - 1-39	56
S42139101	Y - 1-41	56
S42140100	Y - 1-43	56
S42141100	Y - 1-45	58
S42142100	Y - 1-50	58
S42143100	Y - 1-46	58
	Y - 1-51	58
S42144101	Y - 1-55	58
S42145001	Y - 1-56	58
S42146101	Y - 1-60	58
S42147101	Y - 1-60-1	58
S42148101	Y - 1-60-2	58
S42149000	Y - 1-62	58
S42150100	Y - 1-63	58
S42151100	Y - 1-64	58
S42152100	Y - 1-65	58
S42153000	Y - 1-66	58
S42154000	Y - 1-67	58
S42156000	Y - 1-72	58
S42157000	Y - 1-73	58
S42158000	Y - 1-74	58
S42260000	U1 - 1-22	40
S42838001	X - 2	54
S42867001	X - 2-2	54
S43171009	U1 - 1-2	40
S43173001	U1 - 1-50	40
S43192000	G - 5	18
S43193000	G - 5-1	18
	G - 45-1	18
S43194000	G - 45	18
S43210001	U1 - 1-53	40
S43274000	U1 - 1-33	40
S43275000	U1 - 1-35	40
S43285000	E - 1-2	10
S43286009	U2 - 5-9-1	44
S43291009	U2 - 5-1-1	42

CODE	REF.NO.	Page
S43292009	U2 - 5-2-1	42
S43293009	U2 - 5-3-1	42
S43294009	U2 - 5-3-1	42
S43295009	U2 - 5-5-1	42
S43298009	U2 - 5-8-1	44
S43299009	U1 - 1	40
	U2 - 5-1-1-1	42
	U2 - 5-2-1-1	42
	U2 - 5-3-1-1	42
	U2 - 5-3-1-1	42
	U2 - 5-5-1-1	42
	U2 - 5-8-1-1	44
	U2 - 5-9-1-1	44
S43300009	U1 - 1-1	40
S43301009	U1 - 1-3	40
S43304000	U1 - 1-27	40
S43305000	U1 - 1-28	40
S43306000	U1 - 1-29	40
S43307000	U1 - 1-30	40
S43308000	U1 - 1-34	40
S43309000	U1 - 1-41	40
S43310000	U1 - 1-61	40
S43311000	U1 - 1-62	40
S43313001	U1 - 1-51	40
S43316001	U1 - 1-52	40
S43318000	U1 - 1-36	40
S43320001	W - 1	52
S43321000	W - 1-1	52
S43322000	W - 1-1-1	52
S43323001	W - 2	52
S43324000	W - 2-1	52
S43325001	W - 5	52
S43326000	W - 5-1	52
S43328000	W - 6	52
S43329000	W - 6-1	52
S43330001	W - 14	52
S43331000	W - 14-1	52
S43332000	W - 14-1-1	52
S43333000	W - 16-1	52
S43337000	c - 1-10	74
	a1 - 1-3	66
S43338000	c - 1-10	74
	a1 - 1-3	66
S43339000	c - 1-10	74
	a1 - 1-3	66
S43340000	c - 1-10	74
	a1 - 1-3	66
S43341000	c - 1-10	76
	a2 - 1-3	70
S43342000	c - 1-10	76
	a2 - 1-3	70
S43343000	c - 1-10	76
	a2 - 1-3	70
S43344000	V - 42-7	50
	V - 46	48
S43345000	X - 1-3-1	54
S43346001	X - 1	54
S43347000	G - 150	20
S43348000	G - 151	20
S43349000	E - 50	10
S43350000	U1 - 1-21	40
S43351001	T - 3	38
S43352001	T - 3-3	38

CODE	REF.NO.	Page
S43355000	U1 - 1-14	40
S43356001	U1 - 1-7	40
S43357000	V - 9-2	46
S43358000	W - 52	52
S43359000	Y - 1-93	58
S43408001	d - 11-1-1-1	78
S43409001	d - 11-1-2-1	78
S43410001	d - 11-1-1-1	78
S43411001	d - 11-1-2-1	78
S43450001	d - 11-1-1-2	78
	d - 11-1-1-2	78
S43451001	d - 11-1-2-2	78
	d - 11-1-2-2	78
S43683001	V - 42-3-1-1	50
S43701001	d - 11-1	78
S43702001	d - 11-1-1	78
S43703001	d - 11-1-2	78
S43704001	d - 11-1	78
S43705001	d - 11-1-1	78
S43706001	d - 11-1-2	78
S43707001	T - 1	38
S43708009	C - 12	8
S43710001	C - 1	8
S43711000	C - 18	8
S43713001	Z - 72	62
S43714000	Z - 71	62
S43715001	Z - 54	60
S43716001	Z - 55	60
S43717001	G - 9	18
S43718001	G - 49	18
S43719001	G - 42	18
S43720001	G - 67	18
S43723001	Q - 36	34
S43729000	Z - 50	60
S43731001	V - 10	46
S43732001	Q - 54	34
S43747001	T - 6	38
S43749001	G - 87	20
S43769000	V - 42-5	50
	V - 47	48
S43770000	V - 42-6	50
	V - 48	48
S43772000	V - 9	46
S43809001	Y - 1-41	56
S44213001	V - 42-3	50
S44214000	V - 42-3-1	50
S44215000	V - 42-3-4	50
S44216000	V - 42-3-4-1	50
S44217000	V - 42-3-4-4	50
S44218000	V - 42-3-4-5	50
S44219001	V - 42-3-9	50
S44223000	V - 42-3-1-2	50
S44224000	V - 42-3-1-3	50
S44225000	V - 42-3-1-5	50
S44226000	V - 42-3-1-6	50
S44228000	V - 42-3-4-2	50
S44229000	V - 42-3-4-3	50
S44230000	V - 42-3-4-6	50
S44238001	a1 - 1	64
S44239001	a1 - 1	64
S44240001	a1 - 1	64
S44271001	a1 - 1	64
S44272001	a2 - 1	68

索引 / INDEX / VERZEICHNIS  
/ INDEX / INDICE

CODE	REF.NO.	Page
S44273001	a2 - 1	68
S44274001	a2 - 1	68
S44275001	c - 1	74
S44276001	c - 1	74
S44277001	c - 1	74
S44278001	c - 1	74
S44279001	Y - 1	56
S44281001	Y - 1	56
S44283001	c - 1	76
S44284001	c - 1	76
S44285001	c - 1	76
S44287000	W - 51	52
S44290009	U2 - 5-1	42
S44291009	U2 - 5-5	42
S44292009	U2 - 5-2	42
S44293009	U2 - 5-8	44
S44294009	U2 - 5-3	42
S44295009	U2 - 5-3	42
S44296009	U2 - 5-9	44
S44530000	V - 8	46
S44531000	V - 31	46
S44532000	V - 31-1	46
	V - 31-1-1	46
S44551009	W - 53-1	52
S44758000	U2 - 5-1-2	42
	U2 - 5-2-2	42
	U2 - 5-3-2	42
	U2 - 5-3-2	42
	U2 - 5-5-2	42
	U2 - 5-8-2	44
	U2 - 5-9-2	44
S44943000	W - 53-1-3	52
S44944000	W - 53-1-2	52
S45043009	W - 53	52
S60011000	d - 11-1-3	78
	d - 11-1-3	78
U32744000	U1 - 1-53-5	40
U38337000	U1 - 1-53-1	40
U38338000	U1 - 1-53-2	40
U85274000	U1 - 1-61-1	40
0A4300605	U1 - 1-6	40
0A5300805	U1 - 1-5	40
0A5400806	U1 - 1-8	40
	U1 - 1-16	40
0A5401006	U1 - 1-17	40
0A5403006	U1 - 1-13	40
	U1 - 1-15	40
002300403	X - 2-11	54
003300812	Y - 1-40	56
	Y - 1-42	56
004300513	A - 79	4
004400803	X - 2-3	54
004401003	R - 25	36
	a1 - 1-1-25	64
	a2 - 1-1-25	68
008300604	A - 62-1	2
008400604	U1 - 1-40	40
012400636	Q - 33	34
012500536	G - 86	20
014060622	B - 65-2	6
014060632	A - 56	2
	A - 58	2
	A - 68	2

CODE	REF.NO.	Page
014060632	B - 3	6
	B - 9	6
	B - 11	6
	B - 37	6
	C - 13	8
	D - 13	8
	E - 1-6	10
	E - 36	10
	G - 17	18
	G - 68	18
	G - 90	20
	G - 97	20
	H - 9	22
	H - 12	22
	H - 14	22
	H - 16	22
	H - 19	22
	J - 12	24
	J - 14	24
	M - 1-4	30
	M - 14	30
	N - 10	30
	S - 16	38
014060832	L - 27	26
014300832	L - 94	28
014400432	S - 6	38
014400532	F - 45	12
	F - 80-2-15	14
	F - 80-2-15	16
	F - 81-2-15	14
	F - 81-2-15	16
	Y - 1-26	56
	a1 - 1-1-1-15	64
	a1 - 1-2-1-15	66
	a2 - 1-1-1-15	68
	a2 - 1-2-1-15	70
014680622	G - 10	18
014760622	G - 50	18
014770622	G - 54	18
	G - 62	18
016061031	C - 14	8
	H - 3	22
017062503	Z - 68	62
017401415	F - 63	12
018061022	G - 77	18
	U1 - 1-9	40
	U2 - 5-2-1-11	42
	U2 - 5-3-1-11	42
	U2 - 5-3-1-11	42
	U2 - 5-8-1-11	44
	U2 - 5-9-1-11	44
018061236	A - 60	2
018061622	E - 2	10
	G - 43	18
	G - 88	20
018062022	D - 11	8
018062522	H - 27	22
018065022	Z - 51	60
	Z - 56	60
018081636	J - 2	24
018082036	A - 82	4
018300532	L - 96	28
018301236	B - 16	6

CODE	REF.NO.	Page
018301236	D - 23	8
018301632	B - 23-1	6
	D - 24-2	8
	L - 7-2	26
018400832	A - 35	2
	B - 64	6
	E - 14	10
	E - 24	10
	H - 53	22
	R - 1-2	36
018400836	Y - 1-30	56
018401032	F - 94	12
	S - 15	38
	a1 - 1-2-6	66
	a2 - 1-2-6	70
018401236	Q - 2	34
	Y - 1-7	56
	Y - 1-11	56
	Y - 1-22	56
	Y - 1-28	56
018401622	G - 6	18
	G - 46	18
018401636	E - 18	10
	G - 24	18
	Y - 1-20	56
018402032	B - 21	6
018501036	B - 33	6
018501222	A - 42	2
	H - 26	22
018501236	F - 80-2-13	14
	F - 80-2-13	16
	F - 81-2-13	14
	F - 81-2-13	16
	a1 - 1-1-1-13	64
	a1 - 1-2-1-13	66
	a2 - 1-1-1-13	68
	a2 - 1-2-1-13	70
018501422	E - 1-3	10
	G - 52	18
018501622	H - 25-3	22
018501631	G - 13	18
	G - 83	20
018501636	Y - 1-2	56
018502022	G - 100	20
018502036	K - 16	24
018503036	Y - 1-60-3	58
018680822	G - 82	20
021060102	A - 22	2
	D - 9	8
021060106	Z - 69	62
021060306	Q - 31	34
021080306	D - 3	8
021100202	Z - 62	60
021300206	A - 62-2	2
	W - 9	52
021300302	F - 80-2-7	14
	F - 80-2-7	16
	F - 81-2-7	14
	F - 81-2-7	16
	L - 33	26
	S - 11	38
	d - 11-1-1-5	78
	d - 11-1-1-5	78

索引 / INDEX / VERZEICHNIS  
/ INDEX / INDICE

CODE	REF.NO.	Page
021300302	d - 11-1-2-5	78
	d - 11-1-2-5	78
	a1 - 1-1-1-7	64
	a1 - 1-2-1-7	66
	a2 - 1-1-1-7	68
	a2 - 1-2-1-7	70
021350106	N - 6	30
	S - 9	38
021400202	A - 71	2
	F - 64	12
	F - 103	12
	L - 57	26
	R - 7	36
	R - 13	36
	S - 13	38
	X - 1-9	54
	b - 2-1-4	72
	a1 - 1-1-7	64
	a1 - 1-1-13	64
	a2 - 1-1-7	68
	a2 - 1-1-13	68
021500106	Z - 4-8-3	60
	Z - 4-12-1	60
	Z - 4-13-1	60
021500216	Y - 1-3	56
021500303	B - 35-2	6
021630102	L - 105	28
	b - 2-10-8	72
021660102	F - 97	12
	a1 - 1-2-9	66
	a2 - 1-2-9	70
025030232	A - 62-3	2
	W - 7	52
025030236	X - 2-13	54
025040132	G - 8	18
	G - 48	18
025040232	F - 7	12
	G - 25	18
	N - 4	30
	Q - 66	34
	W - 32	52
	W - 34	52
	b - 2-1-11	72
025040234	W - 4	52
	Y - 1-49	58
	Y - 1-54	58
	Y - 1-91	58
025050232	E - 1-4	10
	K - 17	24
	Z - 75	62
025060232	U1 - 1-11	40
	U2 - 5-2-1-13	42
	U2 - 5-3-1-13	42
	U2 - 5-3-1-13	42
	U2 - 5-8-1-13	44
	U2 - 5-9-1-13	44
025060236	Y - 1-78	58
025060332	A - 20	2
025080132	A - 83	4
025100132	Z - 63	62
025350236	L - 82	28
025680132	L - 77	28
	T - 8	38

CODE	REF.NO.	Page
025800332	Z - 67	62
026040136	V - 42-3-7	50
	V - 42-3-8	50
	Y - 1-13	56
028030242	M - 9	30
028030243	W - 10	52
	W - 14-4	52
	Y - 1-92	58
028030246	X - 2-12	54
028040242	F - 19	12
	F - 71	12
	H - 56	22
028040246	V - 42-3-3	50
	V - 42-3-6	50
028050242	A - 43	2
028050243	Y - 1-60-4	58
028050246	Z - 4-8-2	60
028060242	G - 78	18
	Z - 52	60
	Z - 57	60
	Z - 70	62
028060246	U1 - 1-10	40
	U2 - 5-2-1-12	42
	U2 - 5-3-1-12	42
	U2 - 5-3-1-12	42
	U2 - 5-8-1-12	44
	U2 - 5-9-1-12	44
028080242	J - 4	24
028100242	Z - 64	62
031452206	Z - 4-13-2	60
031553202	V - 42-2	50
	V - 42-4	50
032422003	V - 35	46
	Y - 1-61	58
032461606	Z - 78	62
047502242	A - 30	2
	A - 51	2
048030342	F - 15	12
	F - 43	12
	L - 78	28
	V - 4	46
	V - 13	46
	V - 52	48
	Y - 1-18	56
	b - 2-1-15	72
048050142	F - 80-2-11	14
	F - 80-2-11	16
	F - 81-2-11	14
	F - 81-2-11	16
	F - 92	12
	a1 - 1-1-1-11	64
	a1 - 1-2-1-11	66
	a1 - 1-2-4	66
	a2 - 1-1-1-11	68
	a2 - 1-2-1-11	70
	a2 - 1-2-4	70
048050342	F - 1-4	12
	F - 2-4	12
	S - 4	38
048050346	X - 2-15	54
048060342	G - 57	18
	G - 65	18
048080142	A - 45	2

CODE	REF.NO.	Page
048080142	A - 48	2
048100142	E - 11-5	10
	E - 23-5	10
	Z - 60	60
048120142	J - 1-5	24
	K - 12-5	24
	Y - 1-9	56
048150142	C - 11	8
	K - 2	24
048160242	G - 66	18
048260242	E - 11-3	10
	E - 23-3	10
048280242	G - 93	20
	J - 1-3	24
	K - 12-4	24
048320242	J - 7	24
048350242	C - 17	8
052400606	W - 50	52
	X - 2-16	54
052400806	Z - 73	62
060020416	F - 80-2-1-2	14
	F - 80-2-1-2	16
	F - 81-2-1-2	14
	F - 81-2-1-2	16
	a1 - 1-1-1-1-2	64
	a1 - 1-2-1-1-2	66
	a2 - 1-1-1-1-2	68
	a2 - 1-2-1-1-2	70
060300416	L - 60	26
	P - 44	32
	Y - 47	58
	Y - 52	58
060300616	X - 1-11	54
060350616	L - 39	26
	b - 2-10-12	72
	a1 - 1-1-1-17	64
	a1 - 1-2-1-17	66
	a2 - 1-1-1-17	68
	a2 - 1-2-1-17	70
060400416	Y - 1-48	58
	Y - 1-53	58
060400516	L - 30	26
	Y - 1-37	56
	Y - 1-44	56
060400816	W - 53-3	52
	X - 1-13	54
062260612	R - 20	36
	a1 - 1-1-20	64
	a2 - 1-1-20	68
062300416	G - 28	18
	G - 99	20
	H - 25-5	22
	P - 12	32
	P - 17	32
	R - 18	36
	a1 - 1-1-18	64
	a2 - 1-1-18	68
062300512	A - 64	2
	A - 77	4
	B - 68	6
062300612	L - 13	26
	L - 44	26
062300616	A - 80	4



索引 / INDEX / VERZEICHNIS  
/ INDEX / INDICE

CODE	REF.NO.	Page
062300616	B - 31	6
062300806	W - 14-3	52
062301016	F - 11	12
	L - 32	26
	b - 2-10-2	72
062301205	X - 2-6	54
062301414	Y - 1-24	56
	Y - 1-36	56
062301606	W - 8	52
062350516	L - 83	28
	Y - 1-59	58
062350616	P - 4	32
	P - 37	32
	Q - 7	34
	Q - 27	34
	V - 41	46
062351615	L - 3	26
062400612	Q - 37	34
	Q - 39	34
	T - 4	38
062400616	P - 6	32
	P - 8	32
	P - 10	32
	R - 15	36
	a1 - 1-1-15	64
	a2 - 1-1-15	68
062400812	A - 12	2
	A - 24	2
	A - 27	2
	A - 95	4
	F - 8	12
	F - 17	12
	F - 65	12
	F - 100	12
	H - 40	22
	H - 48	22
	H - 55	22
	N - 3	30
	Q - 29	34
	Q - 53	34
	Q - 56	34
	Q - 58	34
	Q - 69	34
	V - 6	46
	W - 3	52
	W - 15	52
	W - 18	52
	W - 22	52
	W - 30	52
	W - 31	52
	W - 33	52
	b - 2-2	72
	b - 2-4	72
	b - 2-6	72
062400816	V - 37	46
062401016	F - 80-2-9	14
	F - 80-2-9	16
	F - 81-2-9	14
	F - 81-2-9	16
	T - 2	38
	a1 - 1-1-1-9	64
	a1 - 1-2-1-9	66
	a2 - 1-1-1-9	68

CODE	REF.NO.	Page
062401016	a2 - 1-2-1-9	70
062401212	Q - 67	34
	W - 42	52
	b - 2-1-12	72
062401416	L - 63	26
062401616	Y - 1-79	58
062403512	V - 42-3-2	50
	V - 42-3-5	50
062500804	A - 6	2
	A - 96	4
062500812	A - 54	2
062501006	Z - 4-13-3	60
062501202	A - 4	2
	A - 10	2
	F - 38	12
	F - 40	12
	L - 11	26
	L - 18	26
062501406	Z - 4-12-4	60
062670616	Q - 45	34
062681412	T - 7	38
072620180	E - 16	10
072620260	C - 2	8
076000800	E - 11-2	10
	E - 23-2	10
076001800	G - 92	20
	J - 1-4	24
	K - 12-3	24
076001850	E - 33	10
076002450	C - 10	8
076002800	J - 6	24
076003850	K - 1	24
	L - 93	28
076202850	K - 5	24
100257010	A - 93-3	4
101118001	Z - 74	62
101572101	Z - 9	60
102630001	F - 1-2	12
	F - 2-2	12
102843004	C - 23	8
105073001	Z - 77	62
105288001	L - 37	26
	b - 2-10-10	72
106129002	A - 93-4	4
107017002	A - 39	2
	A - 88	4
109763002	F - 1-3	12
	F - 2-3	12
113006001	P - 14	32
114483002	Z - 18	60
114486002	A - 53	2
115947001	A - 19	2
116920001	C - 21	8
	J - 11	24
117150001	P - 36	32
117466000	Z - 19	60
117936001	X - 2-17	54
117936009	A - 89	4
118837001	Z - 8	60
122257001	Z - 53	60
126863001	Z - 4-3	60
128652001	G - 84-2	20
140342001	Z - 21	60

CODE	REF.NO.	Page
140553102	B - 18	6
140682001	Y - 1-60-1-2	58
141276001	C - 22	8
141514002	B - 53	6
141542001	R - 10	36
	a1 - 1-1-10	64
	a2 - 1-1-10	68
142627001	E - 34	10
142642001	H - 46	22
142990001	Z - 4-11-3	60
143196001	P - 39	32
	P - 40	32
	P - 45	32
144103009	Q - 19	34
144504001	L - 70	28
	Q - 41	34
	Q - 60	34
	b - 2-1-5	72
144749001	c - 1-13	74
	c - 1-13	74
	c - 1-13	74
	c - 1-13	74
	c - 1-13	76
	c - 1-13	76
	c - 1-13	76
	c - 1-13	76
145446001	Q - 11	34
146124001	X - 1-10	54
147236001	Q - 65	34
	b - 2-1-10	72
148294001	B - 47	6
148407001	L - 102	28
	b - 2-10-5	72
148727001	D - 19	8
148782001	G - 101	20
149287000	U1 - 1-4	40
149796001	Z - 6	60
150173003	Z - 4-6	60
150174000	Z - 4-7-1	60
150179002	Z - 4-8-1	60
150180001	Z - 4-1	60
150182000	Z - 4-2	60
150183000	Z - 4-11-2	60
150188009	Z - 4-9	60
150206000	Z - 4-5-2	60
150206002	Z - 4-4-1	60
150207001	Z - 4-5-1	60
150592009	U1 - 1-32	40
150607009	A - 75	2
150644009	Q - 32	34
150756009	A - 92	4
151998000	C - 20	8
152861101	Z - 58	60
152862001	Z - 59	60
152863001	Z - 65	62
152864000	Z - 66	62
152865201	Z - 61	60
152889001	Q - 44	34
152948001	P - 35	32
152969001	V - 40	46
153098000	A - 93-2	4
153242000	Z - 80	62
	U1 - 1-50-18	40
153274001	Y - 1-60-1-3	58

From the library of: Diamond Needle Corp

索引 / INDEX / VERZEICHNIS  
/ INDEX / INDICE

CODE	REF.NO.	Page
153596001	D - 26	8
153675001	B - 27	6
153787001	R - 28	36
	c - 1-5	74
	c - 1-5	74
	c - 1-5	74
	c - 1-5	74
	c - 1-5	76
	c - 1-5	76
	c - 1-5	76
	a1 - 1-1-26	64
	a2 - 1-1-26	68
154465001	A - 52	2
154562001	L - 68	28
	Q - 42	34
	Q - 61	34
	b - 2-1-6	72
154702101	Z - 20	60
155510001	L - 69	28
	Q - 43	34
	Q - 62	34
	b - 2-1-7	72
155559001	D - 7	8
156112003	Z - 4-5	60
158437009	A - 90	4
158581000	V - 34	46
158827009	A - 14	2
159113001	L - 108	28
	b - 2-9-3	72
159220101	Q - 10	34
159221001	Q - 20	34
159458009	A - 18	2
159805001	Q - 18	34
164348001	W - 53-2	52
192737132	Z - 4-15	60
200190001	Z - 81	62
228475000	T - 3-2	38
	X - 2-7	54
	U1 - 1-44	40
232384001	U1 - 1-50-8	40
340400001	V - 39	46
417526000	G - 11-2	18
530138001	G - 56	18
	G - 64	18
552907000	W - 29	52

Name of parts \ 品名

電線ラベル \ 針

Label, elec. shock  
\ 4 lang.

操作注意ラベル \ 針

Label, operation  
Eng.

Mark, injury  
\ 針

Mark, arrow  
\ 針

Mark, grounding  
\ 針



From the library of: Diamond Needle Corp